

# Screed-flush duct UBSF

Technical information





# Table of contents

|                                               |          |                         |          |                                |           |
|-----------------------------------------------|----------|-------------------------|----------|--------------------------------|-----------|
| <b>Solutions for the building of tomorrow</b> | <b>5</b> | <b>Duct system UBSF</b> | <b>8</b> | <b>Planning &amp; assembly</b> | <b>18</b> |
| <b>The system at a glance</b>                 | <b>6</b> | UBSF                    | 9        | Cable assignment in the duct   | 18        |
|                                               |          | UBSFPTS                 | 10       | Assembly steps                 | 19        |
|                                               |          | UBSFPT                  | 10       |                                |           |
|                                               |          | UBSFD4                  | 10       |                                |           |
|                                               |          | UBSFMD4 R               | 11       |                                |           |
|                                               |          | UBSFMD4 V               | 11       |                                |           |
|                                               |          | UBSFES                  | 12       |                                |           |
|                                               |          | UBSFMAA                 | 12       |                                |           |
|                                               |          | UBSFMAB                 | 13       |                                |           |
|                                               |          | UBSFW                   | 13       |                                |           |
|                                               |          | UM                      | 14       |                                |           |
|                                               |          | UBDSLFM                 | 14       |                                |           |
|                                               |          | UN                      | 14       |                                |           |
|                                               |          | UBSFQT                  | 15       |                                |           |
|                                               |          | UBSFQTF                 | 15       |                                |           |
|                                               |          | UBSFPTES                | 15       |                                |           |
|                                               |          | UBSFPTMA                | 16       |                                |           |
|                                               |          | UBSFS                   | 16       |                                |           |
|                                               |          | UGD 10                  | 16       |                                |           |
|                                               |          | KLF                     | 17       |                                |           |
|                                               |          | UEBSEL                  | 17       |                                |           |



# Solutions for the building of tomorrow

## Duct system UBSF

**Screed-flush systems are particularly suitable in areas that are frequently adapted to changing conditions of use.**

The new screed-flush duct system UBSF is a free-standing system for screed-flush cable routing. Previous systems have maintained their stability via a fixed connection to the screed. However, these constructions contradict the „Screeds in construction“ standard. According to this standard, the screed must be separated from rising components by joints. The creation of joints is necessary for reasons of building physics. According to their function, expansion joints should absorb changes in the screed's shape in all directions and edge joints should reduce sound transmission.

This style of construction can compensate for construction tolerances. Height adjustments to the entire system can also be made after the screed has been applied. Due to the complete decoupling from the neighbouring structure, the impact sound behaviour of the system is very good and a higher sound insulation level (assessed on the basis of VDI 4100) is achieved.

In general, screed-flush duct systems make it easy to adapt the electrical installation, even after the system has been completed. They are designed so that the covers can be removed along the entire length of the duct. The duct is completed with the floor covering joint profile, allowing the floor surface to be neatly attached to the duct. The covering joint profile is a reversible profile made of stainless steel, which can be used for two different installation situations. The carpet edge is recessed flush during screed installation. As soon as the floor layer starts work, the profile is turned around, marking the course of the channel and creating a clean contact edge for the floor covering.

The duct system UBSF is made of 100% steel, so cutting work and length adjustments can be realised with little effort. The UBSF system consists of 2 metre long ducts with widths of 200, 300, 400, 500 or 600 mm. The construction of the screed-flush system UBSF is designed in such a way that barrier-free cable routing is possible. To ensure the load capacity of the system, centre supports are used from the 400 mm wide duct solution upwards. The standard length of the duct covers is 1,000 mm; alternatively, 500 mm long covers can also be used. The covers are supplied unbolted to maximise the efficiency of the drainage on site. The material thickness of the cover is 4 mm. This makes the lids suitable for handling on site despite their length of one or 0.5 metres. The combination of cover and crossbeam creates a stable system that is designed for office traffic loads. The screed-flush system UBSF can be used in rooms where the floor is dry to damp cleaned.

The wide levelling range of the screed-flush system UBSF from 60 to 255 mm enables flexible and uncomplicated planning. If units are to be placed in the duct run, we recommend a minimum levelling range of 100 mm. If units are used, the usable duct cross-section is reduced accordingly. Fittings are supplied as a kit and consist of upper and lower sections, crossbeams and levelling feet plus connecting materials (clamps and nuts).

# The system at a glance

The screed-flush duct UBSF consists of a pre-assembled base unit and separate covers as well as various fittings. The base unit is designed in such a way that it achieves its stability without a fixed connection to the neighbouring structure. This allows subsequent height adjustments to be made in accordance with standardised building tolerances. The complete decoupling ensures that the system also fulfils the necessary impact sound requirements.

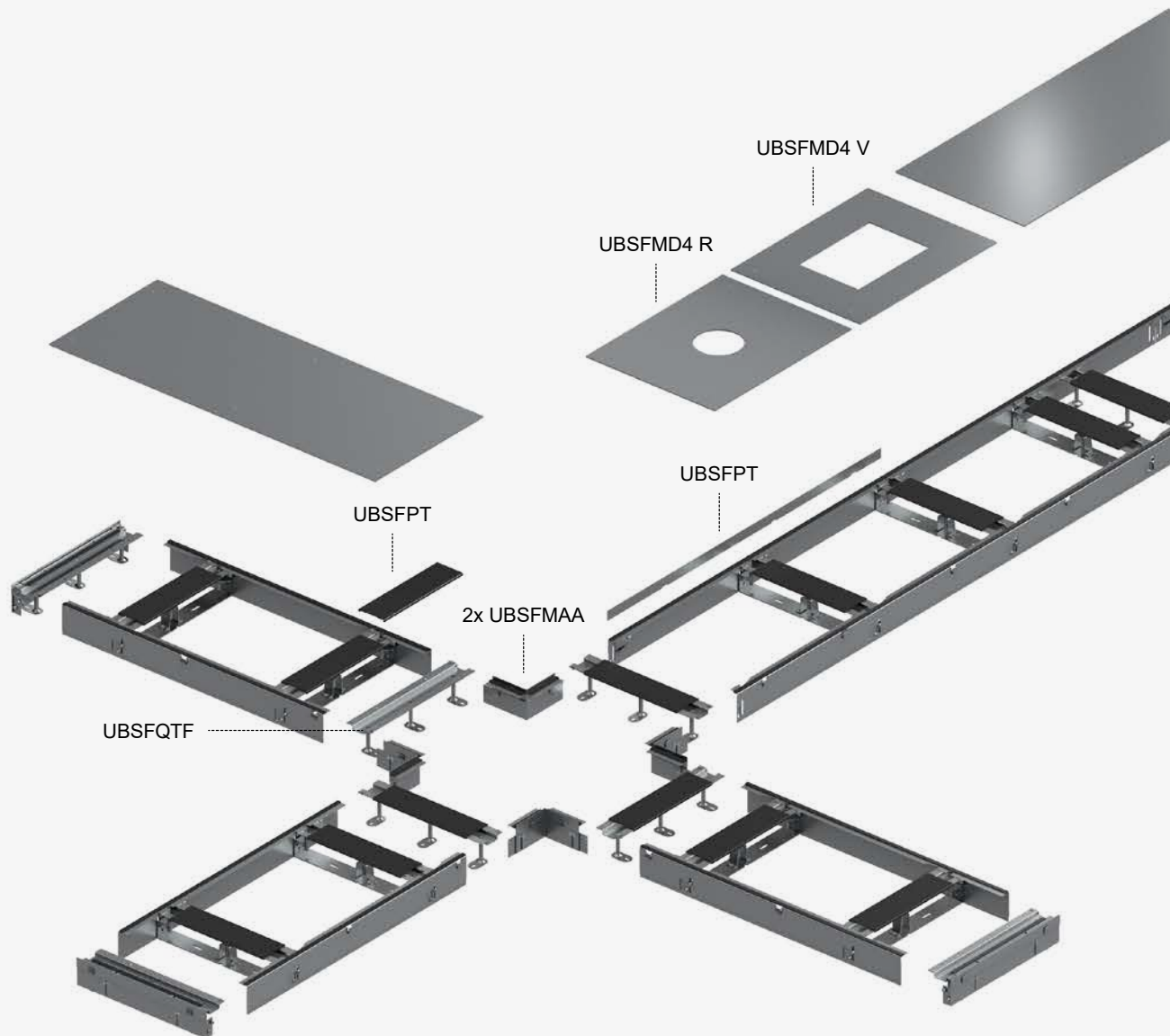

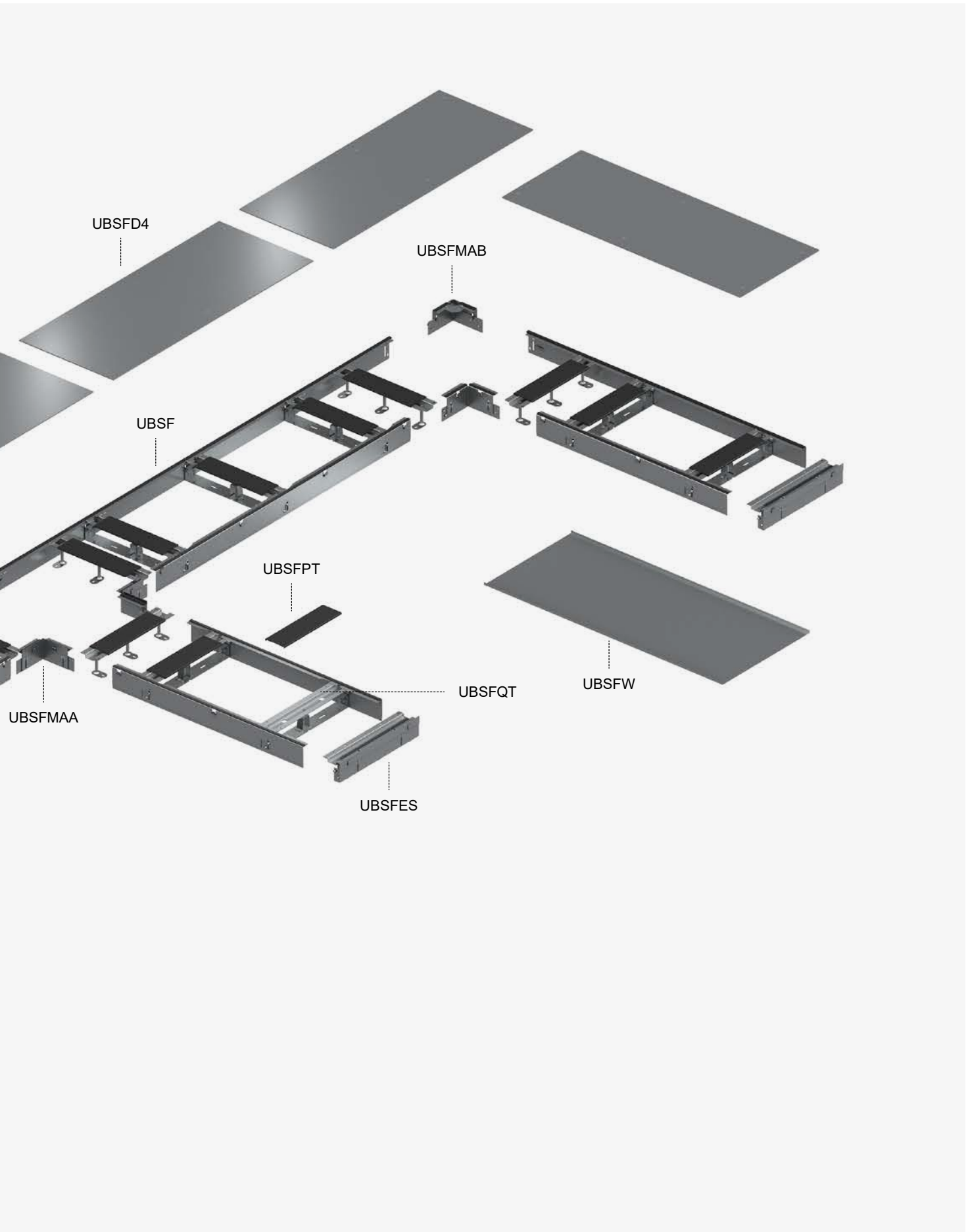





# Duct system UBSF



## Areas of application

The duct system UBSF is the ideal equipment for rooms that can be used in a variety of ways and where great importance is attached to keeping the technical equipment up to date. The simple retrofitting options and flexible positioning of the installation units make it possible to be versatile without having to forego the advantages of an underfloor system.



Technical  
building equipment



## Advantages

- Permanent access to the cables allows easy retrofitting
- Use of installation units enables spatial flexibility
- Barrier-free cable routing
- Complete decoupling from neighbouring structures
- Subsequent adjustments possible in accordance with building tolerances



# UBSF

## Screed-flush duct, free-standing

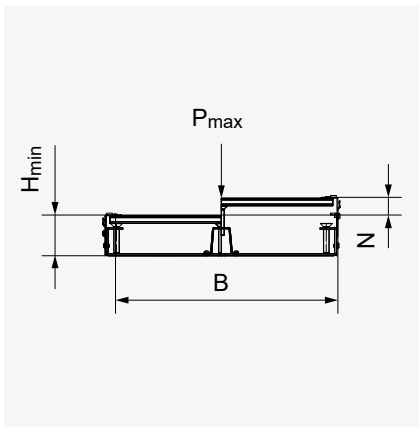
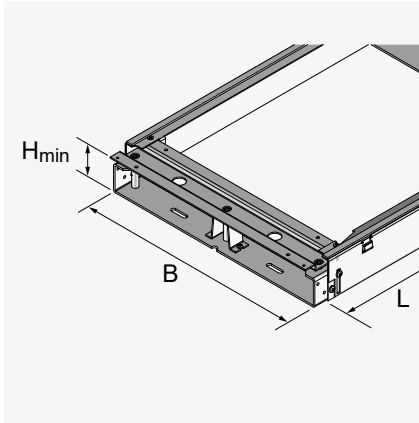

Screed-flush duct, open system with removable covers for horizontal cable routing. Consists of pre-assembled side panels, levelling brackets, crossbeams and accessories. Suitable for rooms with dry and wet-maintained floor surfaces. Designed for traffic loads in offices.

- Material: hot-dip galvanised sheet steel
- Installation type: installation on bare concrete ceiling
- Area of application: dry and wet-maintained floor surfaces
- Load: with test stamp Ø 13 / 130 mm: 1.5 / 2 kN
- In accordance with DIN EN 50085
- Certified by VDE

| Article             | H <sub>min</sub><br>[mm] | N<br>[mm] | B<br>[mm] | L<br>[mm] | P <sub>max</sub><br>[kN] | G<br>[kg] |
|---------------------|--------------------------|-----------|-----------|-----------|--------------------------|-----------|
| <b>UBSF 60-20S</b>  | 60                       | 20        | 200       | 2000      | 3.0                      | 6.18      |
| <b>UBSF 60-30S</b>  | 60                       | 20        | 300       | 2000      | 3.0                      | 7.59      |
| <b>UBSF 60-40S</b>  | 60                       | 20        | 400       | 2000      | 3.0                      | 9.00      |
| <b>UBSF 60-50S</b>  | 60                       | 20        | 500       | 2000      | 3.0                      | 10.06     |
| <b>UBSF 60-60S</b>  | 60                       | 20        | 600       | 2000      | 3.0                      | 11.12     |
| <b>UBSF 75-20S</b>  | 75                       | 30        | 200       | 2000      | 3.0                      | 7.97      |
| <b>UBSF 75-30S</b>  | 75                       | 30        | 300       | 2000      | 3.0                      | 9.35      |
| <b>UBSF 75-40S</b>  | 75                       | 30        | 400       | 2000      | 3.0                      | 10.82     |
| <b>UBSF 75-50S</b>  | 75                       | 30        | 500       | 2000      | 3.0                      | 11.88     |
| <b>UBSF 75-60S</b>  | 75                       | 30        | 600       | 2000      | 3.0                      | 12.94     |
| <b>UBSF 100-20S</b> | 100                      | 55        | 200       | 2000      | 3.0                      | 9.50      |
| <b>UBSF 100-30S</b> | 100                      | 55        | 300       | 2000      | 3.0                      | 10.88     |
| <b>UBSF 100-40S</b> | 100                      | 55        | 400       | 2000      | 3.0                      | 12.50     |
| <b>UBSF 100-50S</b> | 100                      | 55        | 500       | 2000      | 3.0                      | 13.56     |
| <b>UBSF 100-60S</b> | 100                      | 55        | 600       | 2000      | 3.0                      | 14.52     |
| <b>UBSF 150-20S</b> | 150                      | 105       | 200       | 2000      | 3.0                      | 13.39     |
| <b>UBSF 150-30S</b> | 150                      | 105       | 300       | 2000      | 3.0                      | 14.77     |
| <b>UBSF 150-40S</b> | 150                      | 105       | 400       | 2000      | 3.0                      | 16.36     |
| <b>UBSF 150-50S</b> | 150                      | 105       | 500       | 2000      | 3.0                      | 17.42     |
| <b>UBSF 150-60S</b> | 150                      | 105       | 600       | 2000      | 3.0                      | 18.47     |

H<sub>min</sub>: Minimum installation height | N: Levelling range | B: Width | L: Length | P<sub>max</sub>: Maximum permissible load | G: Weight

**Included:**

- 4x UBSFQT Crossbeam, p. 15
- 1x UGD 10-3 Rubber seal, p. 16

**Optional:**

- UBSFPT Covering joint profile, p. 10
- UBSFD4 Dummy cover, p. 10
- UBSFMD4 R Mounting cover, for round parts, p. 11
- UBSFMD4 V Mounting cover, for angular parts, p. 11
- UN Nail plug, p. 14

# UBSFPTS

## Impact sound profile

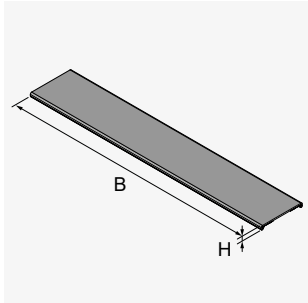

Support profile for the screed-flush duct system UBSF.

- Material: PVC
- In accordance with DIN EN 50085
- Certified by VDE

| Article           | H<br>[mm] | B<br>[mm] | G<br>[kg] |
|-------------------|-----------|-----------|-----------|
| <b>UBSFPTS 20</b> | 7         | 86        | 0.027     |
| <b>UBSFPTS 30</b> | 7         | 186       | 0.058     |
| <b>UBSFPTS 40</b> | 7         | 286       | 0.089     |
| <b>UBSFPTS 50</b> | 7         | 386       | 0.120     |
| <b>UBSFPTS 60</b> | 7         | 486       | 0.151     |

H: Height | B: Width | L: Length | G: Weight

# UBSFPT

## Covering joint profile

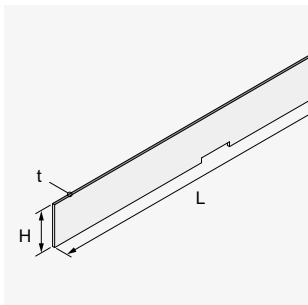

Covering joint profile for the screed-flush duct system UBSF as reversible profile for a 0 and 3 mm covering level.

- Material: stainless steel
- In accordance with DIN EN 50085
- Certified by VDE

| Article         | H<br>[mm] | L<br>[mm] | t<br>[mm] | G<br>[kg] |
|-----------------|-----------|-----------|-----------|-----------|
| <b>UBSFPT E</b> | 26        | 1,000     | 1.5       | 0.311     |

H: Height | L: Length | t: Material thickness | G: Weight

# UBSFD4

## Dummy cover

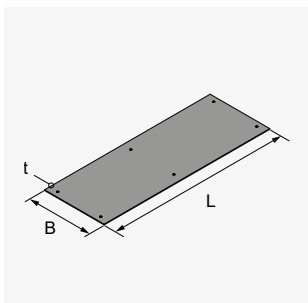

Dummy cover for the screed-flush duct system UBSF.

- Material: hot-dip galvanised sheet steel
- In accordance with DIN EN 50085
- Certified by VDE

| Article              | B<br>[mm] | L<br>[mm] | t<br>[mm] | G<br>[kg] | included:    |
|----------------------|-----------|-----------|-----------|-----------|--------------|
| <b>UBSFD4 20S</b>    | 200       | 500       | 4         | 3.078     | 4x GFST 5x12 |
| <b>UBSFD4 30S</b>    | 300       | 500       | 4         | 4.647     | 4x GFST 5x12 |
| <b>UBSFD4 40S</b>    | 400       | 500       | 4         | 6.215     | 4x GFST 5x12 |
| <b>UBSFD4 50S</b>    | 500       | 500       | 4         | 7.778     | 4x GFST 5x12 |
| <b>UBSFD4 60S</b>    | 600       | 500       | 4         | 9.352     | 4x GFST 5x12 |
| <b>UBSFD4 20-10S</b> | 200       | 1000      | 4         | 6.145     | 6x GFST 5x12 |
| <b>UBSFD4 30-10S</b> | 300       | 1000      | 4         | 9.283     | 6x GFST 5x12 |
| <b>UBSFD4 40-10S</b> | 400       | 1000      | 4         | 12.421    | 6x GFST 5x12 |
| <b>UBSFD4 50-10S</b> | 500       | 1000      | 4         | 15.560    | 6x GFST 5x12 |
| <b>UBSFD4 60-10S</b> | 600       | 1000      | 4         | 18.698    | 6x GFST 5x12 |

B: Width | L: Length | t: Material thickness | G: Weight

## UBSFMD4 R

### Mounting cover, for round parts

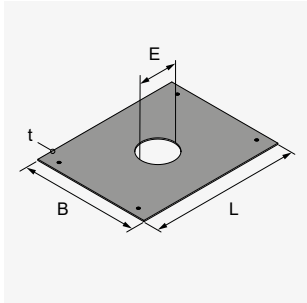

Mounting cover for the screed-flush duct system UBSF for mounting of round parts.

- Material: hot-dip galvanised sheet steel
- In accordance with DIN EN 50085

| Article                 | B<br>[mm] | L<br>[mm] | E<br>[mm] | t<br>[mm] | G<br>[kg] | included:    |
|-------------------------|-----------|-----------|-----------|-----------|-----------|--------------|
| <b>UBSFMD4-122R 20S</b> | 200       | 500       | 122       | 4         | 4.70      | 4x GFST 5x12 |
| <b>UBSFMD4-122R 30S</b> | 300       | 500       | 122       | 4         | 7.82      | 4x GFST 5x12 |
| <b>UBSFMD4-122R 40S</b> | 400       | 500       | 122       | 4         | 10.94     | 4x GFST 5x12 |
| <b>UBSFMD4-260R 40S</b> | 400       | 500       | 260       | 4         | 9.65      | 4x GFST 5x12 |
| <b>UBSFMD4-307R 40S</b> | 400       | 500       | 307       | 4         | 8.93      | 4x GFST 5x12 |
| <b>UBSFMD4-307R 50S</b> | 500       | 500       | 307       | 4         | 12.08     | 4x GFST 5x12 |
| <b>UBSFMD4-307R 60S</b> | 600       | 500       | 307       | 4         | 15.11     | 4x GFST 5x12 |

B: Width | L: Length | E: Installation dimension | t: Material thickness | G: Weight

## UBSFMD4 V

### Mounting cover, for angular parts

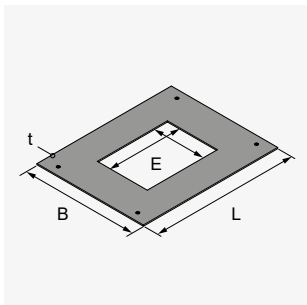

Mounting cover for the screed-flush duct system UBSF for mounting of angular parts.

- Material: hot-dip galvanised sheet steel
- In accordance with DIN EN 50085

| Article                 | B<br>[mm] | L<br>[mm] | E<br>[mm] | t<br>[mm] | G<br>[kg] | included:    |
|-------------------------|-----------|-----------|-----------|-----------|-----------|--------------|
| <b>UBSFMD4-185V 30S</b> | 300       | 500       | 261x186   | 4         | 6.59      | 4x GFST 5x12 |
| <b>UBSFMD4-185V 40S</b> | 400       | 500       | 261x186   | 4         | 9.72      | 4x GFST 5x12 |
| <b>UBSFMD4-260V 40S</b> | 400       | 500       | 261x261   | 4         | 9.20      | 4x GFST 5x12 |
| <b>UBSFMD4-260V 50S</b> | 500       | 500       | 261x261   | 4         | 12.34     | 4x GFST 5x12 |
| <b>UBSFMD4-260V 60S</b> | 600       | 500       | 261x261   | 4         | 15.39     | 4x GFST 5x12 |

B: Width | L: Length | E: Installation dimension | t: Material thickness | G: Weight

# UBSFES

## Levelling end piece

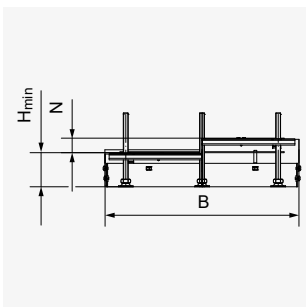
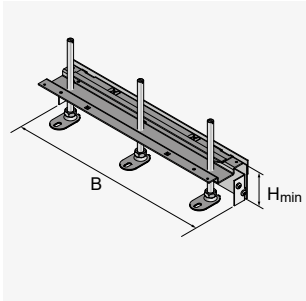

Levelling end piece for the screed-flush duct system UBSF.

- Material: hot-dip galvanised sheet steel
- In accordance with DIN EN 50085
- Certified by VDE

| Article               | H <sub>min</sub><br>[mm] | N<br>[mm] | B<br>[mm] | G<br>[kg] | included:      |
|-----------------------|--------------------------|-----------|-----------|-----------|----------------|
| <b>UBSFES 60-20S</b>  | 60                       | 20        | 197       | 0.60      | 2x UBDSLFM 80  |
| <b>UBSFES 60-30S</b>  | 60                       | 20        | 297       | 0.89      | 2x UBDSLFM 80  |
| <b>UBSFES 60-40S</b>  | 60                       | 20        | 397       | 1.25      | 3x UBDSLFM 80  |
| <b>UBSFES 60-50S</b>  | 60                       | 20        | 497       | 1.54      | 3x UBDSLFM 80  |
| <b>UBSFES 60-60S</b>  | 60                       | 20        | 597       | 1.83      | 3x UBDSLFM 80  |
| <b>UBSFES 75-20S</b>  | 75                       | 30        | 197       | 0.67      | 2x UBDSLFM 150 |
| <b>UBSFES 75-30S</b>  | 75                       | 30        | 297       | 0.99      | 2x UBDSLFM 150 |
| <b>UBSFES 75-40S</b>  | 75                       | 30        | 397       | 1.38      | 3x UBDSLFM 150 |
| <b>UBSFES 75-50S</b>  | 75                       | 30        | 497       | 1.71      | 3x UBDSLFM 150 |
| <b>UBSFES 75-60S</b>  | 75                       | 30        | 597       | 2.03      | 3x UBDSLFM 150 |
| <b>UBSFES 100-20S</b> | 100                      | 55        | 197       | 0.80      | 2x UBDSLFM 150 |
| <b>UBSFES 100-30S</b> | 100                      | 55        | 297       | 1.08      | 2x UBDSLFM 150 |
| <b>UBSFES 100-40S</b> | 100                      | 55        | 397       | 1.63      | 3x UBDSLFM 150 |
| <b>UBSFES 100-50S</b> | 100                      | 55        | 497       | 2.01      | 3x UBDSLFM 150 |
| <b>UBSFES 100-60S</b> | 100                      | 55        | 597       | 2.40      | 3x UBDSLFM 150 |
| <b>UBSFES 150-20S</b> | 150                      | 105       | 197       | 1.04      | 2x UBDSLFM 220 |
| <b>UBSFES 150-30S</b> | 150                      | 105       | 297       | 1.54      | 2x UBDSLFM 220 |
| <b>UBSFES 150-40S</b> | 150                      | 105       | 397       | 2.10      | 3x UBDSLFM 220 |
| <b>UBSFES 150-50S</b> | 150                      | 105       | 497       | 2.60      | 3x UBDSLFM 220 |
| <b>UBSFES 150-60S</b> | 150                      | 105       | 597       | 3.09      | 3x UBDSLFM 220 |

H<sub>min</sub>: Minimum installation height | N: Levelling range | B: Width | G: Weight

# UBSFMAA

## Mounting kit T-junction/crossing

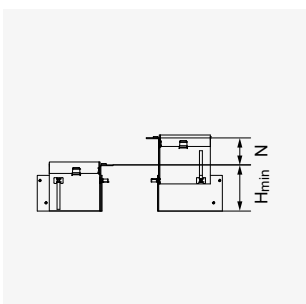
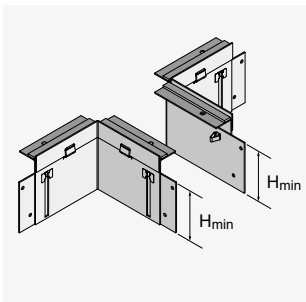

Mounting kit for creating T-junctions within the screed-flush duct system UBSF. Covering joint profiles (covering level: 0 and 3 mm) are already pre-installed. Crossbeam and levelling bases are required, but are not included in the scope of delivery. Up to 300 mm width, 2 levelling bases are required; from 400 mm width, 3 levelling bases are required for each crossbeam.

**To construct a crossing, 2x UBSFMAA are required.**

- Material: hot-dip galvanised sheet steel
- In accordance with DIN EN 50085

| Article             | H <sub>min</sub><br>[mm] | N<br>[mm] | G<br>[kg] |
|---------------------|--------------------------|-----------|-----------|
| <b>UBSFMAA 60S</b>  | 60                       | 20        | 0.58      |
| <b>UBSFMAA 75S</b>  | 75                       | 30        | 0.65      |
| <b>UBSFMAA 100S</b> | 100                      | 55        | 0.79      |
| <b>UBSFMAA 150S</b> | 150                      | 105       | 1.05      |

H<sub>min</sub>: Minimum installation height | N: Levelling range | G: Weight

# UBSFMAB

## Mounting kit ˘90° bend˘

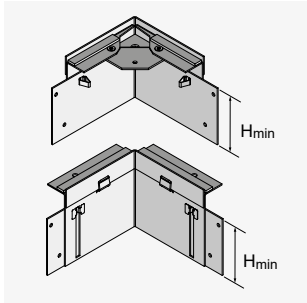

Mounting kit for creating 90° bends within the screed-flush duct system UBSF. Covering joint profiles (covering level: 0 and 3 mm) are already pre-installed. Crossbeam and levelling bases are required, but are not included in the scope of delivery. Up to 300 mm width, 2 levelling bases are required; from 400 mm width, 3 levelling bases are required for each crossbeam.

- Material: hot-dip galvanised sheet steel
- In accordance with DIN EN 50085

| Article             | H <sub>min</sub><br>[mm] | N<br>[mm] | G<br>[kg] |
|---------------------|--------------------------|-----------|-----------|
| <b>UBSFMAB 60S</b>  | 60                       | 20        | 0.91      |
| <b>UBSFMAB 75S</b>  | 75                       | 30        | 1.05      |
| <b>UBSFMAB 100S</b> | 100                      | 55        | 1.32      |
| <b>UBSFMAB 150S</b> | 150                      | 105       | 1.83      |

H<sub>min</sub>: Minimum installation height | N: Levelling range | G: Weight

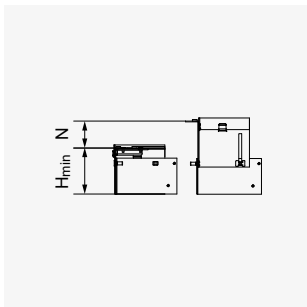

# UBSFW

## Floor tray

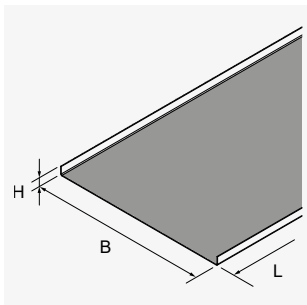

The UBSFW component is a floor tray for the screed-flush duct system UBSF.

- Material: hot-dip galvanised sheet steel
- In accordance with DIN EN 50085

| Article          | H<br>[mm] | B<br>[mm] | L<br>[mm] | t<br>[mm] | G<br>[kg] |
|------------------|-----------|-----------|-----------|-----------|-----------|
| <b>UBSFW 20S</b> | 10        | 200       | 2000      | 0.75      | 2.565     |
| <b>UBSFW 30S</b> | 10        | 300       | 2000      | 0.75      | 3.742     |
| <b>UBSFW 40S</b> | 10        | 400       | 2000      | 0.75      | 4.920     |
| <b>UBSFW 50S</b> | 10        | 500       | 2000      | 0.75      | 6.097     |
| <b>UBSFW 60S</b> | 10        | 600       | 2000      | 0.75      | 7.275     |

H: Height | B: Width | L: Length | t: Material thickness | G: Weight

# UM

## Mounting sleeve

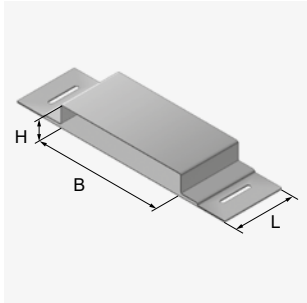

The UM component is a fixing sleeve that is placed between the duct sections when installing screed-covered underfloor duct. The sleeves are used in expansion joints in raw concrete slabs and also to seal joints. They are made of sendzimir hot-dip galvanised sheet steel in accordance with DIN EN 10346. Additional accessories are optionally available.

- Material: hot-dip galvanised sheet steel

| Article           | H<br>[mm] | B<br>[mm] | L<br>[mm] | G<br>[kg] |
|-------------------|-----------|-----------|-----------|-----------|
| <b>UM 28-190S</b> | 28        | 194       | 82        | 0,536     |
| <b>UM 28-250S</b> | 28        | 254       | 82        | 0,630     |
| <b>UM 28-350S</b> | 28        | 354       | 82        | 0,786     |
| <b>UM 38-190S</b> | 38        | 194       | 82        | 0,548     |
| <b>UM 38-250S</b> | 38        | 254       | 82        | 0,642     |
| <b>UM 38-350S</b> | 38        | 354       | 82        | 0,814     |
| <b>UM 48-190S</b> | 48        | 194       | 82        | 0,535     |
| <b>UM 48-250S</b> | 48        | 254       | 82        | 0,662     |
| <b>UM 48-350S</b> | 48        | 354       | 82        | 0,822     |

H: Height | B: Width | L: Length | t: Material thickness | G: Weight

# UBDSLFM

## Levelling support with nut

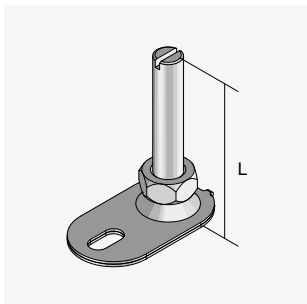

Accessories for height adjustment of the screed-flush duct system UBSF.

- Material: hot-dip galvanised sheet steel
- In accordance with DIN EN 50085
- Certified by VDE

| Article            | L<br>[mm] | G<br>[kg] |
|--------------------|-----------|-----------|
| <b>UBDSLFM 60</b>  | 60        | 0.064     |
| <b>UBDSLFM 80</b>  | 80        | 0.067     |
| <b>UBDSLFM 150</b> | 150       | 0.096     |
| <b>UBDSLFM 220</b> | 220       | 0.122     |

L: Length | G: Weight

# UN

## Nail plug

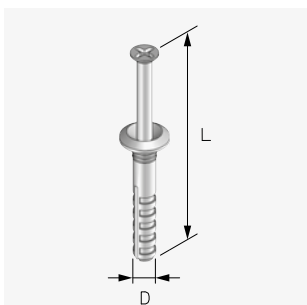

Nail plug for the screed-flush duct system UBSF. For quick assembly, this is already pre-assembled.

- Material: Nylon plug with galvanised steel nail screw
- Max. Thickness of the attachment part: 7 mm

| Article        | D<br>[mm] | L<br>[mm] | G<br>[kg] |
|----------------|-----------|-----------|-----------|
| <b>UN 5/38</b> | 5         | 38        | 0.01      |

D: Diameter | L: Length | G: Weight

## UBSFQT

### Crossbeam

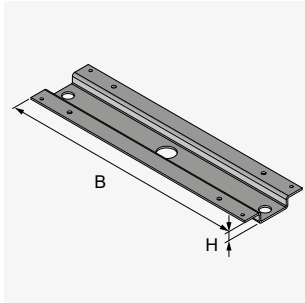

Crossbeam for the screed-flush duct system UBSF as support for cover joints.

- Material: hot-dip galvanised sheet steel
- In accordance with DIN EN 50085
- Certified by VDE

| Article           | H<br>[mm] | B<br>[mm] | G<br>[kg] |
|-------------------|-----------|-----------|-----------|
| <b>UBSFQT 20S</b> | 13        | 200       | 0.254     |
| <b>UBSFQT 30S</b> | 13        | 300       | 0.401     |
| <b>UBSFQT 40S</b> | 13        | 400       | 0.541     |
| <b>UBSFQT 50S</b> | 13        | 500       | 0.688     |
| <b>UBSFQT 60S</b> | 13        | 600       | 0.835     |

H: Height | B: Width | L: Length | G: Weight

## UBSFQTF

### Crossbeam, for fittings

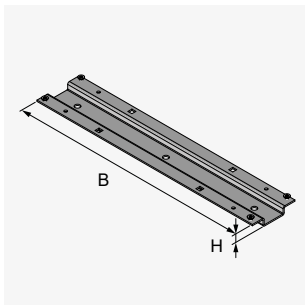

Crossbeam for the screed-flush duct system UBSF for fixing covers and supporting cover joints on fittings.

- Material: hot-dip galvanised sheet steel
- In accordance with DIN EN 50085

| Article            | H<br>[mm] | B<br>[mm] | G<br>[kg] |
|--------------------|-----------|-----------|-----------|
| <b>UBSFQTF 20S</b> | 13        | 200       | 0.262     |
| <b>UBSFQTF 30S</b> | 13        | 300       | 0.405     |
| <b>UBSFQTF 40S</b> | 13        | 400       | 0.551     |
| <b>UBSFQTF 50S</b> | 13        | 500       | 0.698     |
| <b>UBSFQTF 60S</b> | 13        | 600       | 0.845     |

H: Height | B: Width | L: Length | G: Weight

Optional:

UBDSLFM Levelling support with nut, p. 14

## UBSFPTES

### Covering joint profile levelling end piece

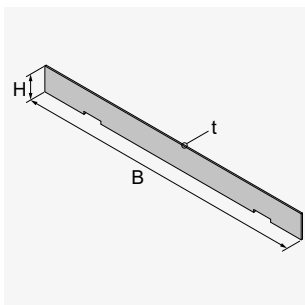

Covering joint profile for levelling end pieces within the screed-flush duct system UBSF.

Reversible profile for a 0 and 3 mm covering level.

- Material: stainless steel
- In accordance with DIN EN 50085
- Certified by VDE

| Article             | H<br>[mm] | B<br>[mm] | t<br>[mm] | G<br>[kg] |
|---------------------|-----------|-----------|-----------|-----------|
| <b>UBSFPTES 20E</b> | 26        | 197       | 1.5       | 0.060     |
| <b>UBSFPTES 30E</b> | 26        | 297       | 1.5       | 0.091     |
| <b>UBSFPTES 40E</b> | 26        | 397       | 1.5       | 0.123     |
| <b>UBSFPTES 50E</b> | 26        | 497       | 1.5       | 0.154     |
| <b>UBSFPTES 60E</b> | 26        | 597       | 1.5       | 0.185     |

H: Height | B: Width | t: Material thickness | G: Weight



## UBSFPTMA

### Covering joint profile mounting kits

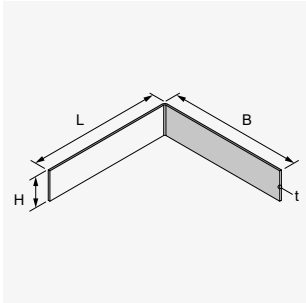

Covering joint profile for 90° bends, T-junctions and crossings within the screed-flush duct system UBSF. For a 0 and 3 mm covering level.

- Material: stainless steel
- In accordance with DIN EN 50085

| Article            | H<br>[mm] | B<br>[mm] | L<br>[mm] | t<br>[mm] | G<br>[kg] |
|--------------------|-----------|-----------|-----------|-----------|-----------|
| <b>UBSFPTMA 0E</b> | 23        | 104       | 104       | 1.5       | 0.057     |
| <b>UBSFPTMA 3E</b> | 26        | 104       | 104       | 1.5       | 0.064     |

H: Height | B: Width | L: Length | t: Material thickness | G: Weight

## UBSFS

### Stencil

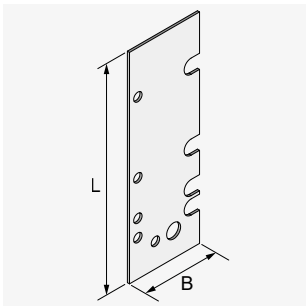

Accessories for the screed-flush duct system UBSF.

- Material: hot-dip galvanised sheet steel
- In accordance with DIN EN 50085

| Article        | B<br>[mm] | L<br>[mm] | t<br>[mm] | G<br>[kg] |
|----------------|-----------|-----------|-----------|-----------|
| <b>UBSFS 1</b> | 50        | 143       | 1.5       | 0.077     |

B: Width | L: Length | t: Material thickness | G: Weight

## UGD 10

### Rubber seal

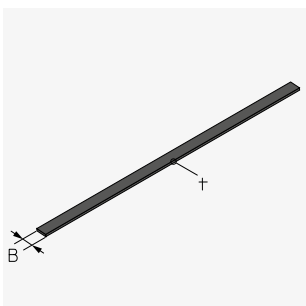

Self-adhesive rubber strip for the screed-flush duct system UBSF.

- Roll 10 m/piece
- Material: rubber
- In accordance with DIN EN 50085
- Certified by VDE

| Article         | B<br>[mm] | t<br>[mm] | G<br>[kg] |
|-----------------|-----------|-----------|-----------|
| <b>UGD 10-3</b> | 10        | 3         | 0.263     |

B: Width | t: Material thickness | G: Weight

# KLF

## Spring clamp fastener

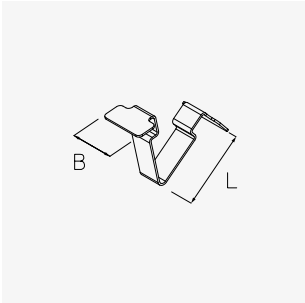

Spring clamp fastener for a quick and easy installation of the screed-flush duct system UBSF.

- Material: stainless steel

| Article     | B<br>[mm] | L<br>[mm] | G<br>[kg] |
|-------------|-----------|-----------|-----------|
| <b>KLFE</b> | 12        | 19        | 0.001     |

B: Width | L: Length | G: Weight

# UEBSEL

## Earthing lug set

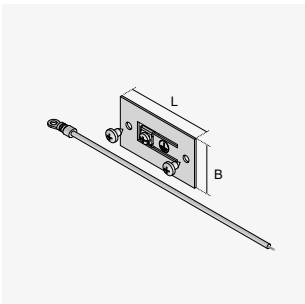

UEBSEL components are earthing lug sets that are used for safe earthing and equipotential bonding when earthing duct trays. The products for screed-flush ducts are made of sendzimir hot-dip galvanised sheet steel (DIN EN 10346) and are supplied with two BLS 4.8X9 self-tapping bolts, one LKS M4X12 button head screw and a UVA-GB-2.5-30 earthing cable. The set components are 40 mm wide and 70 mm long.

| Article       | G<br>[kg] |
|---------------|-----------|
| <b>UEBSEL</b> | 0,052     |

G: Weight

# Planning & assembly

## Cable assignment in the duct

Determining the cable volume is the basis for planning. The cross-sections of the selected, commercially available cable types are average values. The calculation is based on a maximum trunking fill factor of 60 %. Depending on the installation position of the device holders, the area of the duct can only be used for cable routing to a limited extent; the reduction in cross-section must be taken into account here. Current load see DIN VDE 0100/0298.

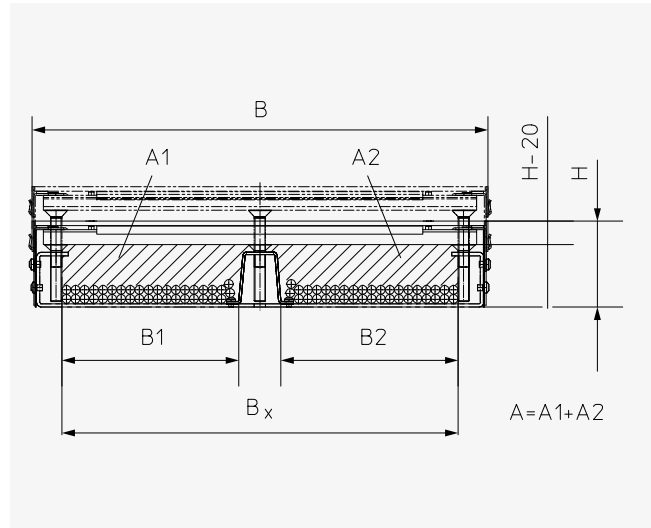

| Article      | H<br>[mm] | H -20<br>[mm] | B<br>[mm] | BX<br>[mm] |     | B1/B2<br>[mm] | A<br>[cm <sup>2</sup> ] | A1 /A2<br>[cm <sup>2</sup> ] | B1 / Power line<br>3x 2.5 mm <sup>2</sup>                          | B2 / Data line<br>Cat.6                                              |
|--------------|-----------|---------------|-----------|------------|-----|---------------|-------------------------|------------------------------|--------------------------------------------------------------------|----------------------------------------------------------------------|
|              |           |               |           | -52        | -88 |               |                         |                              | Quantity Ø 10 mm,<br>Effective cross-section:<br>1 cm <sup>2</sup> | Quantity Ø 8 mm,<br>Effective cross-section:<br>0.64 cm <sup>2</sup> |
| UBSF 60-20S  | 60        | 40            | 200       | 148        | -   | 74            | 59                      | 30                           | 18                                                                 | 28                                                                   |
| UBSF 60-30S  | 60        | 40            | 300       | 248        | -   | 124           | 99                      | 50                           | 30                                                                 | 47                                                                   |
| UBSF 60-40S  | 60        | 40            | 400       | -          | 312 | 156           | 125                     | 62                           | 37                                                                 | 59                                                                   |
| UBSF 60-50S  | 60        | 40            | 500       | -          | 412 | 206           | 165                     | 82                           | 49                                                                 | 77                                                                   |
| UBSF 60-60S  | 60        | 40            | 600       | -          | 512 | 256           | 205                     | 102                          | 61                                                                 | 96                                                                   |
| UBSF 75-20S  | 75        | 55            | 200       | 148        | -   | 81            | 81                      | 41                           | 24                                                                 | 38                                                                   |
| UBSF 75-30S  | 75        | 55            | 300       | 248        | -   | 136           | 136                     | 68                           | 41                                                                 | 64                                                                   |
| UBSF 75-40S  | 75        | 55            | 400       | -          | 312 | 156           | 172                     | 86                           | 51                                                                 | 80                                                                   |
| UBSF 75-50S  | 75        | 55            | 500       | -          | 412 | 206           | 227                     | 113                          | 68                                                                 | 106                                                                  |
| UBSF 75-60S  | 75        | 55            | 600       | -          | 512 | 256           | 282                     | 141                          | 84                                                                 | 132                                                                  |
| UBSF 100-20S | 100       | 80            | 200       | 148        | -   | 74            | 118                     | 59                           | 36                                                                 | 56                                                                   |
| UBSF 100-30S | 100       | 80            | 300       | 248        | -   | 124           | 198                     | 99                           | 60                                                                 | 93                                                                   |
| UBSF 100-40S | 100       | 80            | 400       | -          | 312 | 156           | 250                     | 125                          | 75                                                                 | 117                                                                  |
| UBSF 100-50S | 100       | 80            | 500       | -          | 412 | 206           | 330                     | 165                          | 99                                                                 | 155                                                                  |
| UBSF 100-60S | 100       | 80            | 600       | -          | 512 | 256           | 410                     | 205                          | 123                                                                | 192                                                                  |
| UBSF 150-20S | 150       | 130           | 200       | 148        | -   | 74            | 192                     | 96                           | 58                                                                 | 90                                                                   |
| UBSF 150-30S | 150       | 130           | 300       | 248        | -   | 124           | 322                     | 161                          | 97                                                                 | 151                                                                  |
| UBSF 150-40S | 150       | 130           | 400       | -          | 312 | 156           | 406                     | 203                          | 122                                                                | 190                                                                  |
| UBSF 150-50S | 150       | 130           | 500       | -          | 412 | 206           | 536                     | 268                          | 161                                                                | 251                                                                  |
| UBSF 150-60S | 150       | 130           | 600       | -          | 512 | 256           | 666                     | 333                          | 200                                                                | 312                                                                  |

H: Height | H<sub>N</sub>: Usable height | B: Width | Bx: Usable width | A: Cross section

# Assembly steps



## Notes

- We recommend first aligning the duct, then fixing it to the unfinished floor and then loosening the transport lock.
- Centre support only for the widths 400, 500 and 600 mm.
- Standard delivery length of the covers is 1 m. On request 0.5 m.
- Covers are supplied separately and not screwed on.
- Separators are optional.
- Observe torque values according to DIN EN 50085-1: M4: 1.2 Nm; M5: 2.0 Nm
- The duct system must be included in the equipotential bonding. The UEBSEL set can be used for this purpose.



## Required tools

- Laser/spirit level
- Folding ruler
- Marking tool
- Drilling machine, drill bit (Ø6 mm and Ø7 mm)
- Jigsaw and circular saw
- File/deburring tool
- Screwdriver
- (Torx, cross and slot)
- Rubber mallet
- Ring and open-end spanner (size 17 mm)



## Parts list crossbeam

### Screw type

- UKST M4x10 (ISO 14581)



## Levelling heights

- 60 - 80 mm
- 75 - 105 mm
- 100 - 155 mm
- 150 - 255 mm

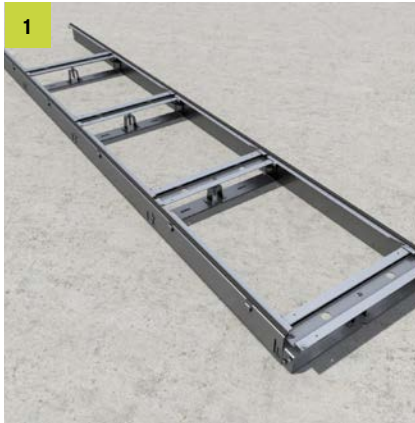

Screed-flush duct system UBSF consists of the base body with four levelling brackets, centre supports, four screwed crossbeams and one loose crossbeam including screws.

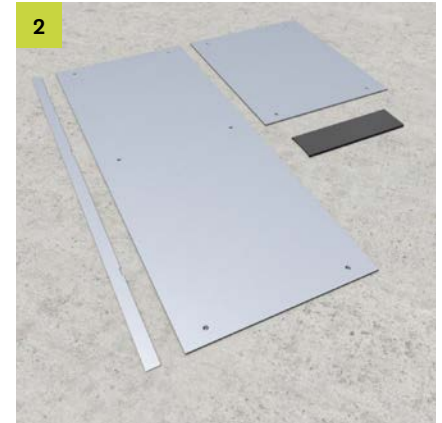

Accessories for the screed-flush duct system:

- 2x cover UBSFD (1 metre each)
- 4x adjusting strips UBSFPT
- 4x impact sound profile UBSFPTS

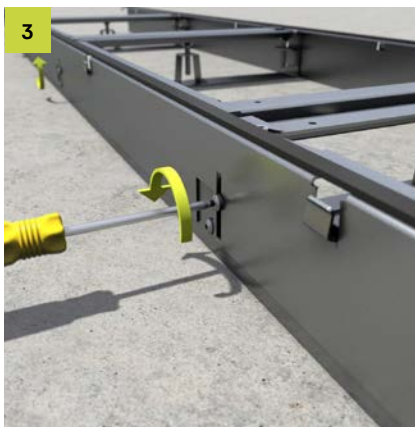

All upper screws must be loosened slightly on both duct walls. When delivered, these are tightened and provide stability during transport.

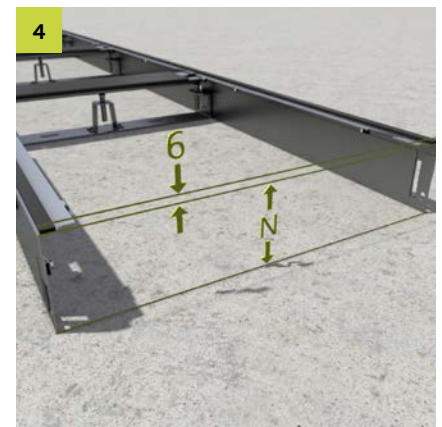

When setting the duct according to the metre tear, the thickness of the cover and the rubber seal (6 mm in total) must be taken into account. Screed height minus 6 mm.

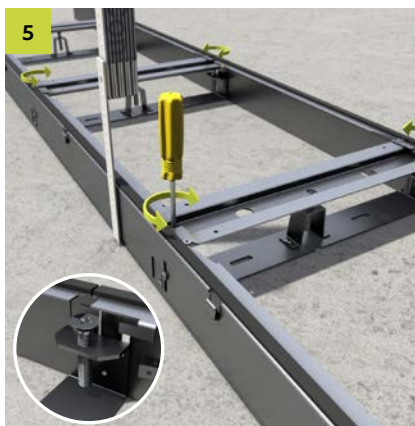

Adjust the height of the duct system using the M10 levelling screws, observing Fig. 4. Screed height according to the metre tear. The duct system may not be loaded.

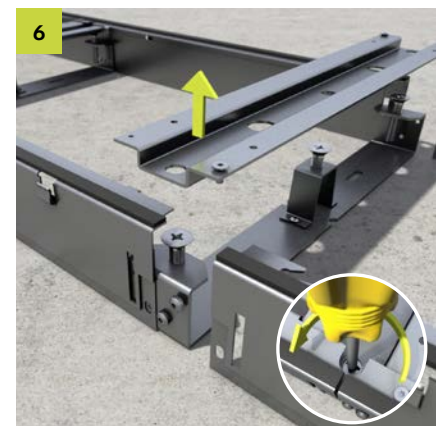

Loosen the M4 screws to remove the pre-assembled crossbeam. Place ducts next to each other. Connect them to each other using the levelling bracket.



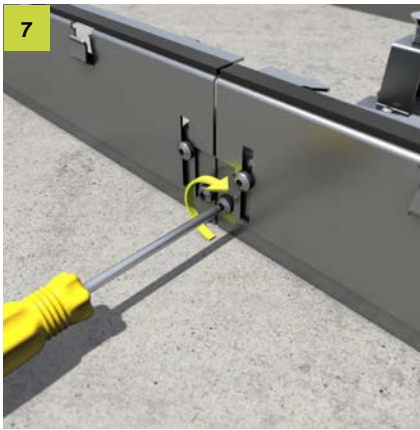

Tighten the lower screws on both sides. These are used to make the firm connection between the side wall and the levelling bracket.

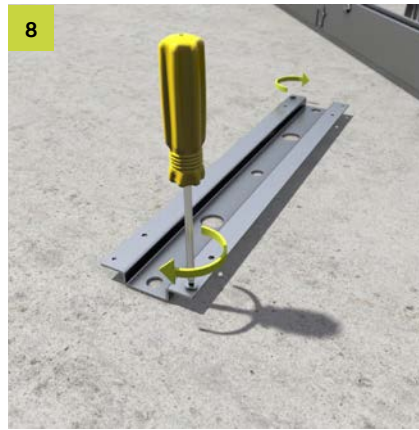

Complete the loosened crossbeam using M4 screws and reinsert.

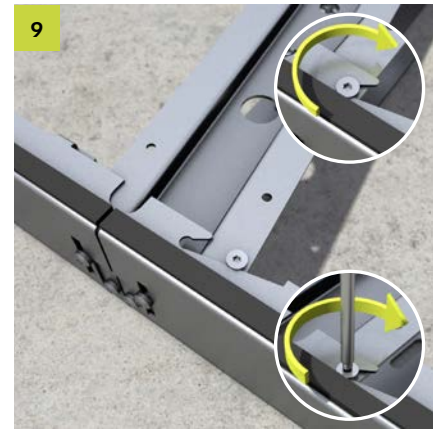

To insert the crossbeam into the duct, the screws must be pushed into the mould opening. Secure both components via the upper screws against loosening.

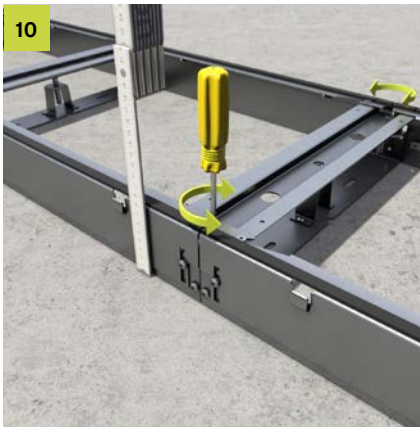

Re-levelling the duct system to screed height on both sides and via the centre support using a laser or digital hose scale.

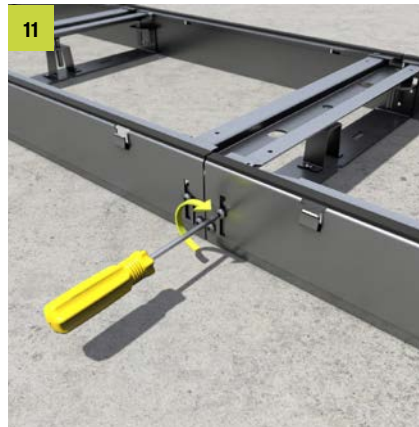

The base body and side walls are connected to each other by the upper screws on the duct wall. This fixes the set levelling height.

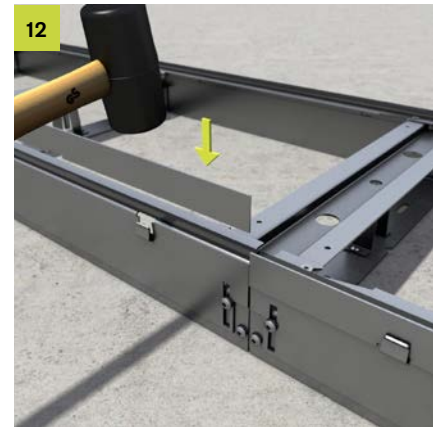

The adjusting strip can be inserted with the help of a rubber mallet.



The impact sound profile is clamped centrally on the crossbeam. The drill holes for fixing the covers may not be covered.

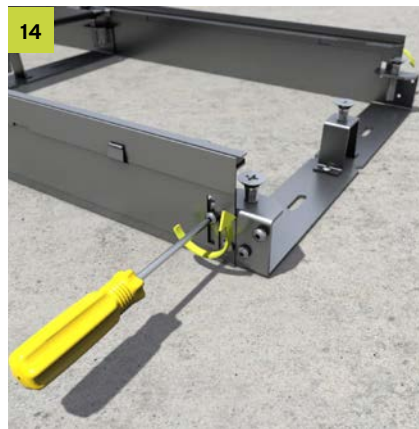

To mount the end piece, the levelling bracket and the associated screws must be removed.



End piece is pre-assembled. The end piece is supplied with a top part, a bottom part, two spring clamp fasteners and two screws.



When the duct has been cut and the end piece is to be set, the bottom part of the end plate must be used to correctly position the connection holes ( $\varnothing 7 \text{ mm}$ ).



The end piece is fixed to the bottom of the duct on both sides using the side fixing screws.



For stabilisation, a crossbeam is inserted and fastened to the end piece from above by two spring clamp fasteners. Screw in the M10 levelling bolts supplied before fixing the crossbeam.

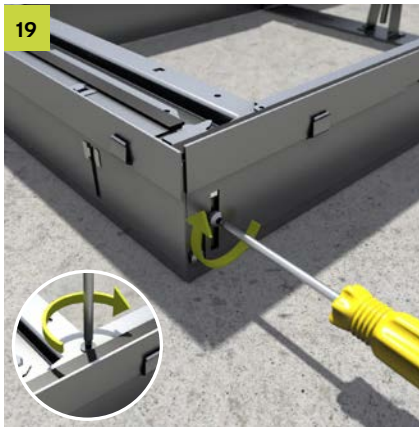

All screws on the duct side and the crossbeam must be tightened. Adjusting strips must be ordered separately.

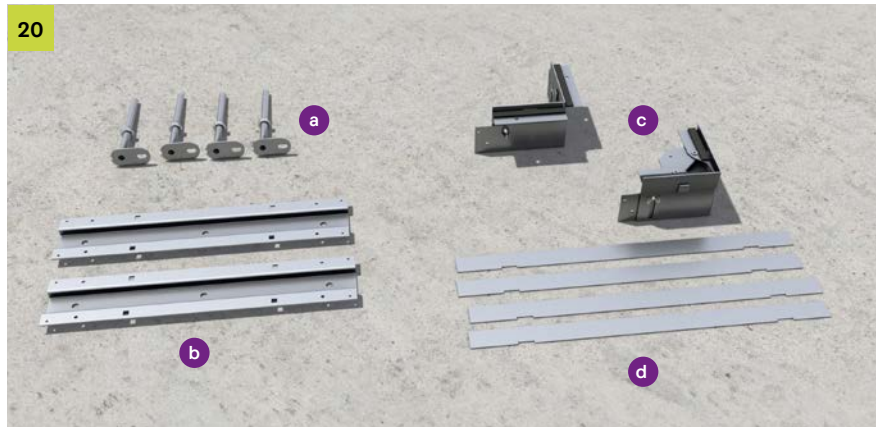

Scope of delivery for the moulded part "corner":

- a 2/4x UBDSLFL (levelling base)
- b 2x UBSFQT (crossbeam with thread)

c 1x UBSFMAB (mounting kit 90° bend)

Cover and adjusting strips (d) must be ordered separately.

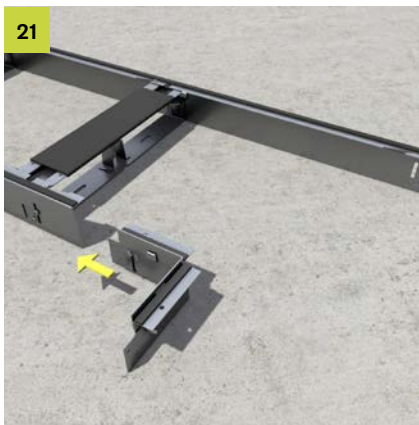

After shortening the duct side, screw the UBSFMAB mounting kit in place using holes and screws. If necessary, use a separately available template to mark the drill holes.

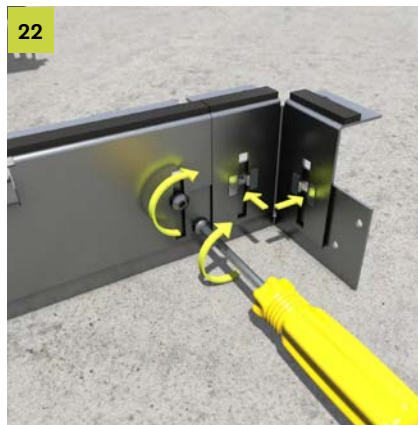

Bend the bottom part of the inner corner at the perforation to form a 90° angle. Then connect the top part and the bottom part of the inner corner using fastening clamps and screw them to the side wall.



Screw the upper and bottom part of the outside corner to the side wall of the duct.



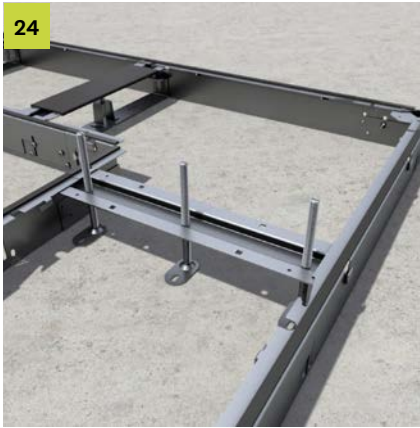

24 Complete the crossbeam with levelling base and then insert the crossbeam into the duct and level it to the correct height.



25 Secure levelling bases against loosening using lock nuts and shorten to the level of the crossbeam surface using a suitable tool.



26 Align the blind cover on the duct and secure it from above using screws.



27 Template is required if the trunking has been shortened. Place the cut duct at the end of the uncut duct and level it to the same height. Place the template over the screws on both sides and drill holes ( $\varnothing$  6 mm) opposite the screw heads. Screw the cut duct to the levelling support.



28 The missing fixing holes for the crossbeam must be re-drilled with a diameter of 6 mm in the cut duct section. The crossbeam can be used as a drilling template for this. A crossbeam must always be placed between two duct sections.

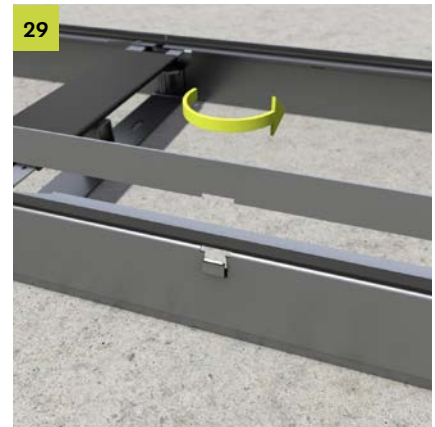

29 The adjusting strip can be set to 0 mm or 3 mm level. At 0 mm level, the notches in the adjusting strip are set flush with the side wall brackets. At 3 mm level, the notches are positioned next to the brackets. To do this, turn the adjusting strip horizontally by 180°.





**PohlCon GmbH**

Nobelstr. 51  
12057 Berlin  
Germany

T +49 30 68283-04  
F +49 30 68283-383

[www.pohlcon.com](http://www.pohlcon.com)