

RAPIDOBAT® Formwork tubes

Technical information



Table of contents

RAPIDOBAT®	4	RAPIDOBAT® Square	16	RAPIDOBAT® Accessories	26
Application notes	5	Technical information	17	Technical information	27
RAPIDOBAT® Cretcon HD	8	RAPIDOBAT® Rectangle, Hexagon and Octagon	18	Service	30
Technical information	9	Technical information	19	Our synergy concept for you	30
For perfect concrete surfaces	10				
		RAPIDOBAT® Custom shapes	22		
RAPIDOBAT® Lined	12	Technical information / variants	23		
Technical information	13				
		RAPIDOBAT® capitals and bases	24		
RAPIDOBAT® Unlined	14	Technical information	25		
Technical information	15				



RAPIDOBAT®

Branded formwork tubes

The product

The Rapidobat® formwork tube system by H-BAU Technik is a formwork package for casting rounded and angular concrete columns quickly and economically. The formwork tubes themselves are made of extremely robust, multilaminated paper and cardboard. The formwork tubes can also be specially treated depending on the exposed concrete specifications and the architect's requirements. A number of designs are available.

Area of application

RAPIDOBAT® formwork tubes seamlessly combine architectural freedom with structural feasibility. Simple erection, casting and stripping for economical and rapid construction. Depending on the client's wishes, columns can be produced with a barely visible spiral marking for lower-level structures, such as cellars or underground car parks, or as premium-finish exposed concrete columns for residential building projects.



Benefits

- Integrated ripcord for easy stripping
- Recyclable material
- Matching capitals and bases available

Application notes

Securing the RAPIDOBAT® formwork tubes

The formwork tubes can be secured using a single bracing level up to a formwork tube length of 4.00 m. Additional levels of bracing must be used for formwork tubes longer than 4.00 m. If heavy-duty tension or compression struts are used for bracing, we recommend installing additional, short pieces of formwork tube beneath the RAPIDO clamping elements. This prevents any pressure marks being created on the formwork tube or finished concrete column.

Lower supports

The base of RAPIDOBAT® formwork tubes can be simply fixed in place using wooden collars (possibly cut using a template) that clasp the tubes tightly from the outside. If formwork with larger diameters is used, we recommend enclosing the formwork tube with a wooden collar approx. 10 cm high at the base. RAPIDO-Fix was specially designed for aligning RAPIDOBAT® Square and Rectangle models: simple, practical, great (see Seite 27).

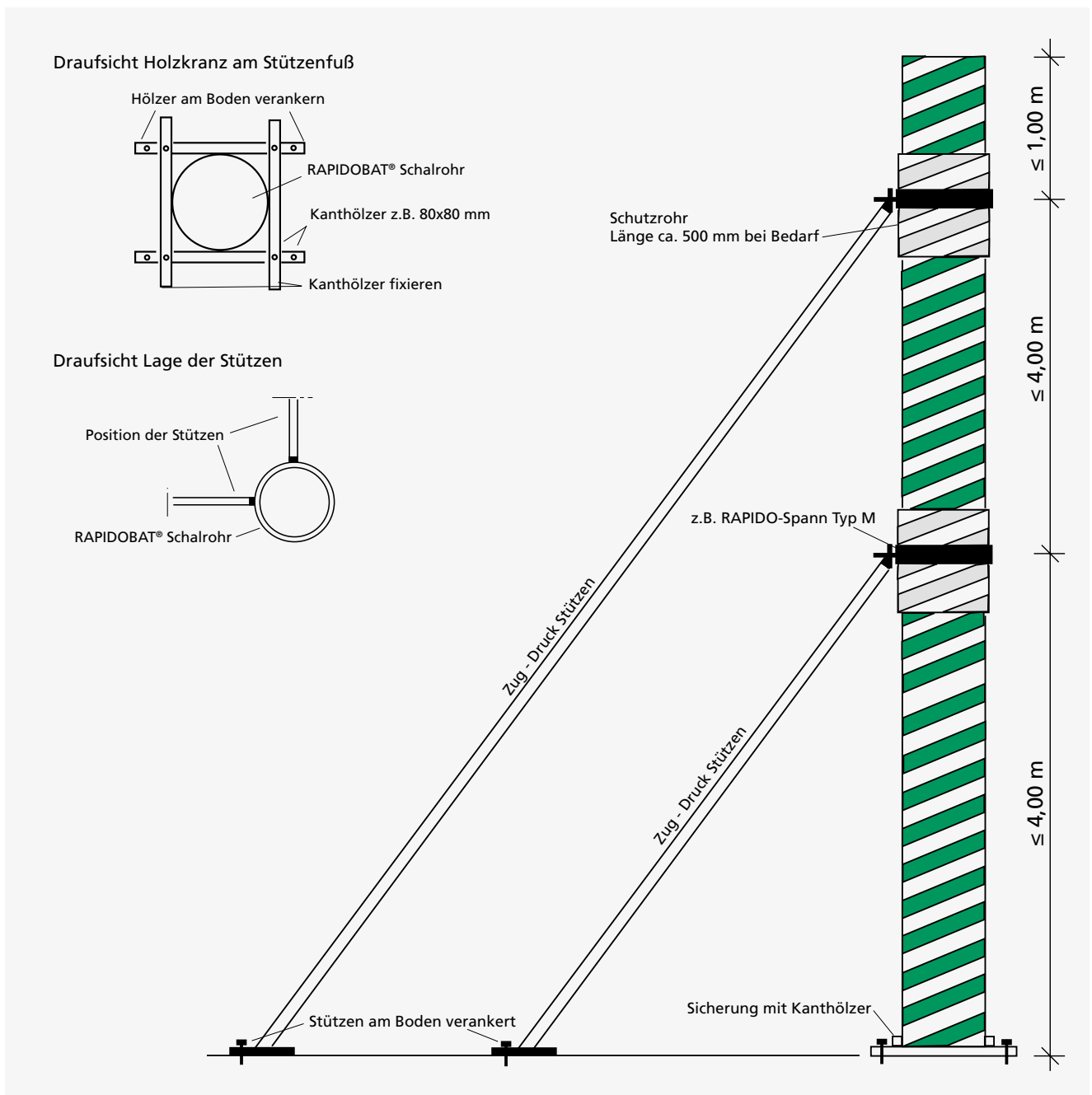

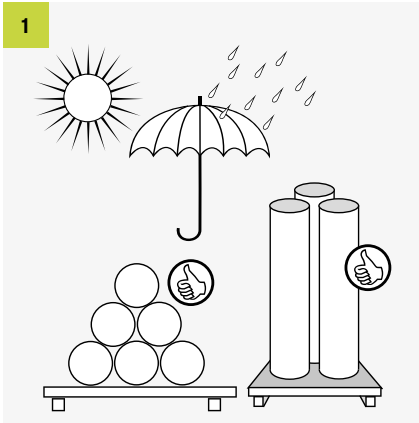

- RAPIDOBAT® formwork tubes must be stored upright and kept dry until used
- Protect against humidity, soil moisture and heat
- COVER THE TOP OF RAPIDOBAT® Cretcon HD elements with film until the concrete is poured
- RAPIDOBAT® Cretcon HD formwork tubes must be processed within the specified time period

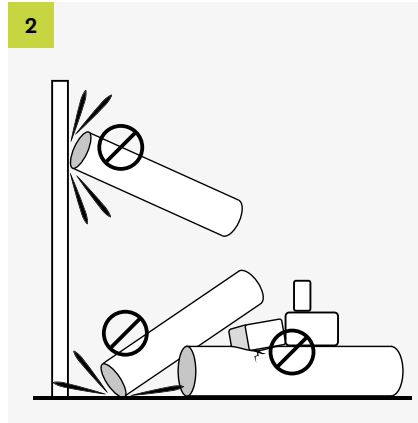

- Check the formwork tube for damage

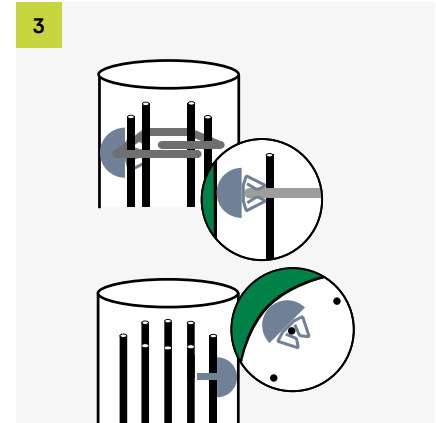

- When choosing the column reinforcements, make sure that the external diameter of the reinforcement cage is not too large.
- When installing the reinforcement cage in the RAPIDOBAT® formwork, there must be sufficient space between the reinforcement and the tube to prevent damaging the inner surface.
- Spacers must not have sharp edges. We recommend using plenty of triangular, fibre concrete surface spacers with hooks.

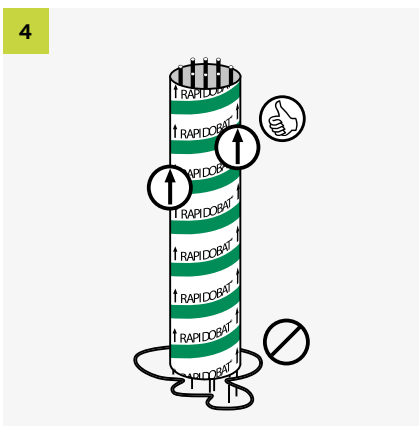

- Remove any standing water from around the columns
- Install RAPIDOBAT® formwork tubes with the arrows pointing upwards

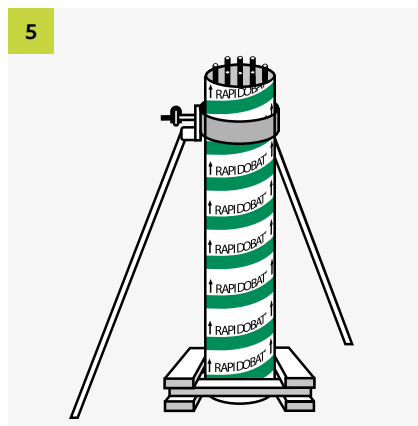

- Fix the base of the formwork tube in place using a wooden collar (possibly cut using a template) that clasps the tube tightly.
- If the columns are over 4 m high, additional struts must be added between the top and bottom bracing elements
- Supports are required every 3 to 4 m in taller sections of formwork

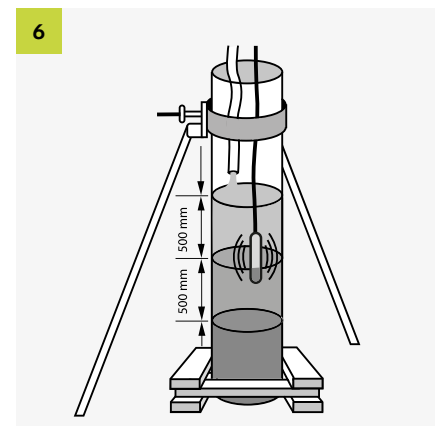

- RAPIDOBAT® formwork tubes are designed to withstand the vibrations and stresses created by an internal vibrator
- Caution: do not use an external vibrator
- Pour the concrete using a filling hose
- All columns must be poured and compacted in layers of 50 cm
- Merge the individual layers together using a needle vibrator

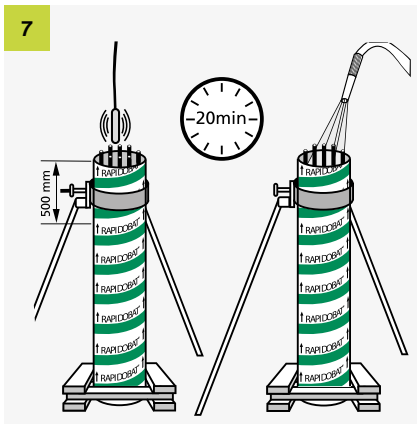

- Re-compact the uppermost poured layer before hydration
- After recompacting the concrete, apply a film of water to the top of the column
- See the DBV fact sheet concerning exposed concrete

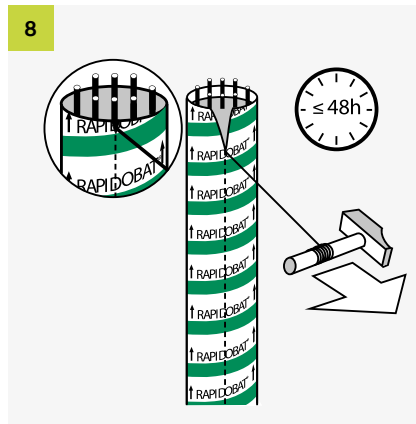

- The ripcord integrated in the formwork tube works like a zip
- Use a knife to cut open the outer cover near the ripcord
- Wrap the ripcord around a hammer handle, for example, and pull downwards from the top
- The formwork tube can then be opened and removed from the column
- Make sure that the tube is completely detached from the surface of the concrete

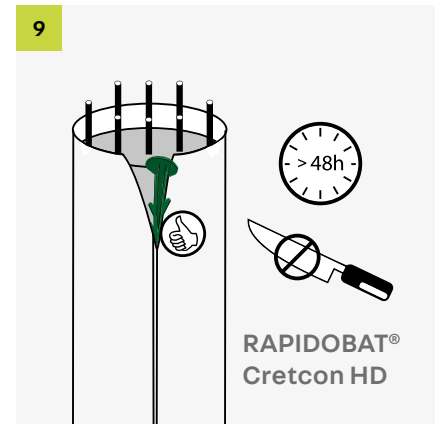

- If you are using RAPIDOBAT® Cretcon HD, the coating must be removed from the column
- Use a knife to score the RAPIDOBAT® Cretcon HD coating at the former position of the ripcord (predetermined break point)
- Push an insulation anchor or a plastic nail up behind the RAPIDOBAT® Cretcon HD coating and pull downwards
- Do not use sharp objects
- The tube can then be repositioned around the column as protection

General information

Casting speed

Tube diameter mm		Casting speed m/h
From	To	
100	300	6.0
300	450	5.0
450	600	3.5
600	1200	2.5

- Casting speeds must be halved if using self-compacting concrete

Stripping times

- RAPIDOBAT® Unlined: within 48 hours
- RAPIDOBAT® Lined: within 48 hours
- RAPIDOBAT® Cretcon HD: after 48 hours at the earliest

Disposal

RAPIDOBAT® formwork tubes can be recycled as paper.

RAPIDOBAT® Cretcon HD

For perfect concrete surfaces



The product

The innovative RAPIDOBAT® Cretcon HD formwork tube has a ground-breaking and certified interior coating. This hydrogel formwork skin self-activates as soon as it comes into contact with fresh concrete. The self-activating RAPIDOBAT® Cretcon HD coating allows exposed concrete columns of unprecedented surface quality to be created.



Benefits:

- Certified exposed concrete class SB 4 thanks to self-activating hydrogel formwork skin
- The new standard for exposed concrete construction
- Pore-free surface with uniform colouring with no additional effort
- Perfect concrete columns requiring no cosmetic improvement



Notes

An integrated ripcord makes it quick and easy to strip the formwork from the reinforced concrete column. The formwork tube can then be used to protect the newly cured concrete.

Technical information

Certified exposed concrete class:

- Highest porosity class P 4
 - Highest colour uniformity class FT 3
 - Highest texture class T 3
 - Highest smoothness class E 3
 - Highest construction joint and formwork shell joint class AF 4
- Exposed concrete class SB 4

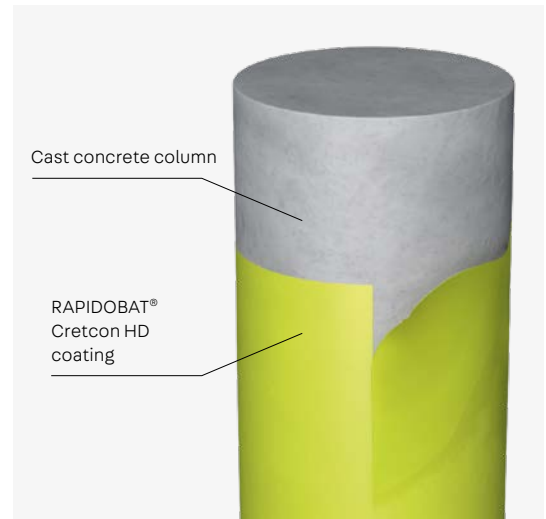

Dimensions

Type	Inside diameter mm	Outside diameter mm	Max. storage length m	Weight kg/m	Concrete consumption m³/m
200	200	207	7.00	2.21	0.031
240	240	248	7.00	2.65	0.045
250	250	258	7.00	2.76	0.049
300	300	309	7.00	4.31	0.071
350	350	361	7.00	4.45	0.096
360	360	371	7.00	5.16	0.102
400	400	411	7.00	5.76	0.126
435	435	446	7.00	6.25	0.149
450	450	463	7.00	7.22	0.159
500	500	515	7.00	8.87	0.196
550	550	567	7.00	9.75	0.196
560	560	575	7.00	9.92	0.246
600	600	615	7.00	10.63	0.283
650	650	667	7.00	12.59	0.332
700	700	717	7.00	13.56	0.385
750	750	769	7.00	15.78	0.442
800	800	821	7.00	18.17	0.503

For perfect concrete surfaces

RAPIDOBAT® Cretcon HD formwork features an innovative, self-activating hydrogel formwork skin that creates a unique concrete surface. This innovation is the answer to the misgivings of former clients and other fans of flawless exposed concrete architecture regarding annoying pores, cavities and mottling.

The official test certificate issued by the Dresden University of Technology's Institute of Construction Materials confirms the excellent results achieved by RAPIDOBAT® Cretcon HD. The test certificate is available to download from our website: www.h-bau.de

Standard cardboard formwork tubes with a plastic film insert were compared to the new, jointless RAPIDOBAT® Cretcon HD tubes in a technical evaluation. Casting was conducted in a technically incorrect manner during the first test run, Test A. During a further test, Test B, the RAPIDOBAT® Cretcon HD formwork tube was cast correctly. To make the conditions more difficult and to illustrate the excellent performance of this H-BAU Technik innovation, concrete was used that is less suitable for the production of high-quality exposed concrete components. The same concrete was used for both casting tests. Hidden pores were exposed before counting the pores.

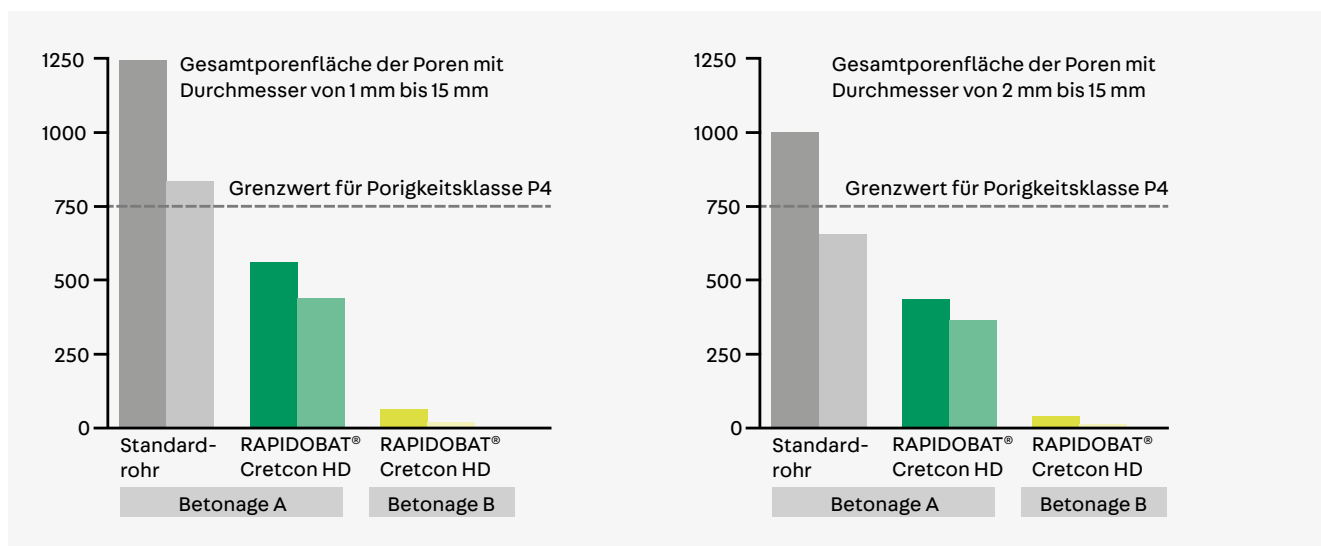

Total pore area as a function of the formwork tube and casting quality for pore diameters 1 - 15 mm and 2 - 15 mm (Source: TU Dresden test report, ref no. 5.5.1 - 38/2012, p. 10)

Pore-free surface without cosmetic improvements

The overall impression of finished columns made using Rapidobat® Cretcon HD formwork tubes is that they have a very uniform colour and matte surfaces. Mottling is practically imperceptible. To achieve the best porosity class of P4 (lowest percentage of pores), the total pore area visible on the surface must not exceed 750 mm². The test surface measures 500 x 500 mm. Despite the tightened requirements of exposed concrete classification standards, the test results confirm the overall impression (see Figure 1):

- **Test A:** despite adverse conditions, the Rapidobat® Cretcon HD specimen achieved a total pore area far below the limit of 750 mm².
- **Test B:** When properly cast, albeit using less suitable concrete,

the finished concrete had an almost pore-free surface when Rapidobat® Cretcon HD was used.

The RAPIDOBAT® Cretcon HD specimens from Test B had an average pore area of 22 mm². This is less than 3% of the maximum allowable pore area of 750 mm².

Cosmetic finishing is no longer necessary. This places the finished product firmly in porosity class P4.

Top-class in every respect

Texture, smoothness, construction joints and formwork shell joints

The special design of the formwork tubes means that the specimens fulfil the highest classification criteria specified in the DBV fact sheet on exposed concrete. In contrast to the standard tubes, RAPIDOBAT® Cretcon HD tubes do not have formwork skin joints and can therefore be firmly placed in the AF 4 formwork shell joint class.

Colour uniformity

The colour of the specimens is so uniform that they achieve the highest classification of FT 3 as specified by the DBV fact sheet on exposed concrete.

Exposed concrete class

The RAPIDOBAT® Cretcon HD specimens achieved the highest exposed concrete class (SB4 – see Table 1), as all surface characteristics were rated comfortably in the highest grades specified by the DBV fact sheet on exposed concrete.

The very low number of pores is particularly notable. So, our innovative RAPIDOBAT® Cretcon HD tubes not only make it easy to fulfil exposed concrete class 4 standards, they also do it with great reliability.

Award-winning system solution

The concept of a self-activating hydrogel formwork skin, as found in RAPIDOBAT® Cretcon HD tubes, also won the 2013 concrete element supplier industry's innovation prize. At the 57th BetonTage convention in Ulm, Germany, an illustrious jury awarded H-BAU Technik the 2013 Innovation Prize.

See the quality of the Innovation Prize winner for yourself and compare the appearance of the concrete surfaces. The left image shows a column created without using RAPIDOBAT® Cretcon HD. The right image shows an almost flawless exposed concrete surface produced using the self-activating hydrogel formwork skin of RAPIDOBAT® Cretcon HD:



Without RAPIDOBAT® Cretcon HD



With RAPIDOBAT® Cretcon HD

Columns made from formwork tubes	Casting	Individual classification					Exposed concrete class
Standard tube	A	P 3	T 3	FT 1	E 3	AF 4	SB 1
RAPIDOBAT® Cretcon HD	A	P 4	T 3	FT 3	E 3	AF 4	SB 4
RAPIDOBAT® Cretcon HD	B	P4	T 3	FT 3	E 3	AF 4	SB 4

Tab.1: Exposed concrete class derived from the individual classifications (source: TU Dresden test report, ref no. 5.5.1 - 38/2012, p. 10)

RAPIDOBAT® lined

For very smooth concrete surfaces



The product

The special film insert creates concrete columns that meet the strict demands of formwork skin class SHK3. This makes RAPIDOBAT® Lined perfect for producing exposed concrete columns very quickly and economically.



Benefits

- Integrated ripcord for easy stripping
- Recyclable material
- Matching capitals and bases available



Notes

An integrated ripcord makes it quick and easy to strip the formwork from the reinforced concrete column. The formwork tube can then be used to protect the newly cured concrete.

Technical information



Dimensions

Type	Inside diameter mm	Outside diameter mm	Max. storage length* m	Weight kg/m	Concrete consumption m ³ /m
150	150	157	7.00	1.49	0.018
200	200	207	7.00	1.98	0.031
240	240	248	7.00	2.37	0.045
250	250	258	7.00	2.47	0.049
300	300	309	7.00	3.96	0.071
350	350	361	7.00	4.05	0.096
360	360	371	7.00	4.74	0.102
400	400	411	7.00	5.40	0.126
435	435	446	7.00	5.89	0.149
450	450	463	7.00	6.82	0.159
500	500	515	7.00	8.66	0.196
550	550	567	7.00	10.44	0.196
560	560	575	7.00	10.62	0.246
600	600	615	7.00	11.39	0.283
650	650	667	7.00	13.40	0.332
700	700	717	7.00	14.44	0.385
750	750	769	7.00	16.72	0.442
800	800	821	7.00	19.17	0.503
900	900	923	7.00	21.56	0.636
1000	1000	1024	7.00	25.70	0.785
1200	1200	1226	6.00	30.78	1.131

* Other dimensions and lengths available on request

RAPIDOBAT® unlined

For smooth concrete surfaces with
subtle spiral markings



The product

RAPIDOBAT® Unlined formwork tubes create smooth concrete surfaces with subtle spiral markings. They are perfect for simple buildings designed with functionality and economy in mind.



Benefits

- Integrated ripcord for easy stripping
- Recyclable material
- Matching capitals and bases available



Notes

An integrated ripcord makes it quick and easy to strip the formwork from the reinforced concrete column. The formwork tube can then be used to protect the newly cured concrete.

Technical information



Dimensions

Type	Inside diameter mm	Outside diameter mm	Max. storage length* m	Weight kg/m	Concrete consumption m ³ /m
150	150	157	7.00	1.26	0.018
200	200	207	7.00	1.68	0.031
240	240	248	7.00	2.01	0.045
250	250	258	7.00	2.09	0.049
300	300	309	7.00	3.51	0.071
350	350	361	7.00	3.52	0.096
360	360	371	7.00	4.20	0.102
400	400	411	7.00	4.69	0.126
435	435	446	7.00	5.09	0.149
450	450	463	7.00	6.02	0.159
500	500	515	7.00	7.53	0.196
550	550	567	7.00	8.28	0.196
560	560	575	7.00	8.42	0.246
600	600	615	7.00	9.03	0.283
650	650	667	7.00	10.85	0.332
700	700	717	7.00	11.69	0.385
750	750	769	7.00	13.78	0.442
800	800	821	7.00	16.03	0.503
900	900	923	7.00	18.03	0.636
1000	1000	1024	7.00	21.77	0.785
1200	1200	1226	6.00	26.07	1.131

* Other dimensions and lengths available on request

RAPIDOBAT® Square

For square reinforced concrete columns



The product

RAPIDOBAT® formwork tubes for square reinforced concrete columns consist of multiple layers of high-quality paper. The specially coated MDF panel inserts inside the RAPIDOBAT® formwork tubes produce a flawless concrete surface. These designs have chamfered corners.

Area of application

The integrated ripcord makes it quick and easy to strip the formwork from the reinforced concrete column. RAPIDOBAT® formwork tubes seamlessly combine architectural freedom with structural feasibility. Simple erection, casting and stripping for economical and rapid construction.



Benefits

- Integrated ripcord for easy stripping
- Recyclable material
- Inner and outer membranes are impermeable to water
- Retains shape even in driving rain
- Matching capitals and bases available

Technical information

The jointless formwork of design A and the inserted corner profiles of design B can be used to produce concrete surfaces with formwork skin qualities of the highest standard.

Design A:
Formwork tubes with integrated chamfer

Design B:
Formwork tubes with plastic corner profile

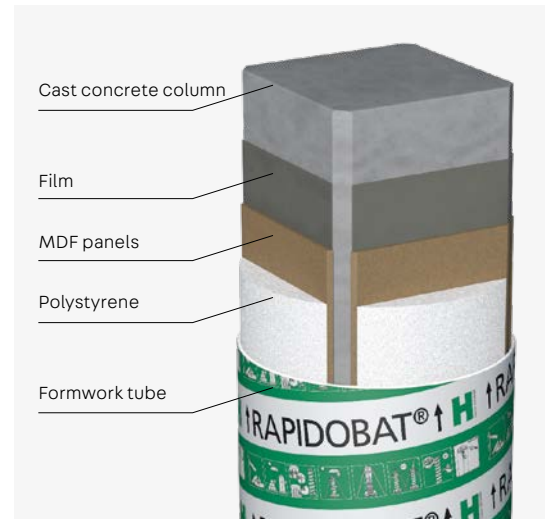
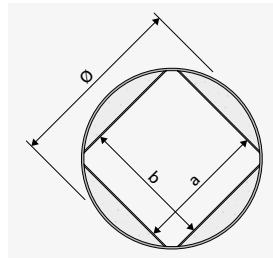

Dimensions

Type	Design	Chamfer mm	Dimensions* a x b mm	Outside diameter mm	Max. storage length** m	Weight kg/m	Concrete consumption m ³ /m
20/20	A	24	200 x 200	273	5.00	6.90	0.040
24/24	A	24	240 x 240	325	5.00	7.30	0.057
25/25	A	24	250 x 250	341	5.00	7.50	0.062
30/30	A	24	300 x 300	410	5.00	9.50	0.089
35/35	B	24	350 x 350	512	5.00	14.10	0.122
40/40	B	24	400 x 400	614	5.00	17.20	0.160
45/45	B	24	450 x 450	665	5.00	21.50	0.202
50/50	B	24	500 x 500	738	5.00	26.80	0.250

* Other dimensions available on request

** Longer lengths available. Horizontal panel joint from 5.00 m

RAPIDOBAT® Rectangle, Hexagon and Octagon

For angular reinforced concrete columns



The product

RAPIDOBAT® formwork tubes for angular reinforced concrete columns consist of multiple layers of high-quality paper. The specially coated MDF panel inserts inside the RAPIDOBAT® formwork tubes produce a flawless concrete surface. These designs all have chamfered corners.

Area of application

The integrated ripcord makes it quick and easy to strip the formwork from the reinforced concrete column. RAPIDOBAT® formwork tubes seamlessly combine architectural freedom with structural feasibility. Simple erection, casting and stripping for economical and rapid construction.



Benefits

- Integrated ripcord for easy stripping
- Recyclable material
- Retains shape even in driving rain
- Matching capitals and bases available

Technical information

RAPIDOBAT® Rectangle

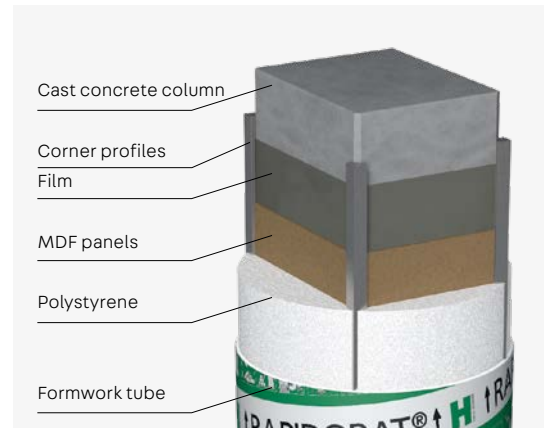
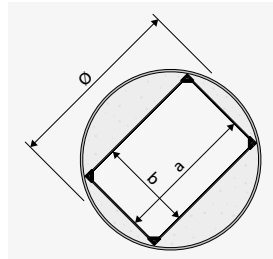

Dimensions

Type	Chamfer mm	Dimensions* a x b mm	Outside diameter mm	Max. storage length** m	Weight kg/m	Concrete consumption m ³ /m
175/240	24	175 X 240	325	4.00	7.80	0.042
200/240	24	200 X 240	359	4.00	8.50	0.048
200/250	24	200 X 250	359	4.00	8.60	0.062
200/300	24	200 X 300	410	4.00	9.80	0.089
200/350	24	200 X 350	460	4.00	9.90	0.122
200/400	24	200 X 400	512	4.00	13.90	0.160
200/450	24	200 X 450	512	4.00	14.20	0.202
200/500	24	200 X 500	572	4.00	15.50	0.250
240/300	24	240 X 300	410	4.00	9.70	0.040
240/350	24	240 X 350	445	4.00	11.00	0.057
240/365	24	240 X 365	461	4.00	12.50	0.062
240/400	24	240 X 400	512	4.00	14.00	0.089
240/450	24	240 X 450	572	4.00	15.30	0.122
240/500	24	240 X 500	572	4.00	15.30	0.160
250/300	24	250 X 300	410	4.00	10.00	0.202
250/350	24	250 X 350	460	4.00	11.10	0.250
250/400	24	250 X 400	512	4.00	14.30	0.089
250/450	24	250 X 450	572	4.00	15.20	0.122
250/500	24	250 X 500	614	4.00	18.00	0.160
300/350	24	300 X 350	512	4.00	13.70	0.202
300/400	24	300 X 400	572	4.00	16.10	0.250
300/450	24	300 X 450	572	4.00	15.50	0.122
300/500	24	300 X 500	614	4.00	17.20	0.160
350/400	24	350 X 400	572	4.00	17.70	0.202
350/450	24	350 X 450	614	4.00	17.50	0.250
350/500	24	350 X 500	665	4.00	20.40	0.160
400/450	24	400 X 450	665	4.00	20.30	0.202
400/500	24	400 X 500	665	4.00	20.10	0.250

* Other dimensions available on request

** Longer lengths available. Horizontal panel joint from 4.00 m

RAPIDOBAT® Hexagon

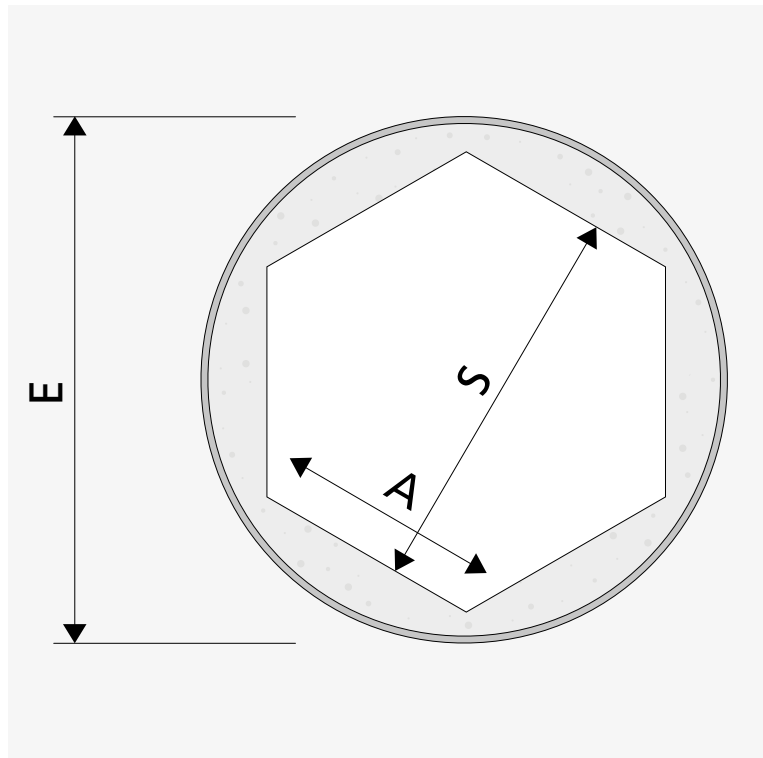

Dimensions

Type	Outside dia. E mm	S mm	A mm	Weight kg/m	Concrete consumption m ³ /m
173/100	209	173	100	2.70	0.03
260/148	307	260	148	4.70	0.06
335/198	410	335	198	6.50	0.10
530/298	614	530	298	11.90	0.23
670/398	818	670	398	22.60	0.41

RAPIDOBAT® Octagon

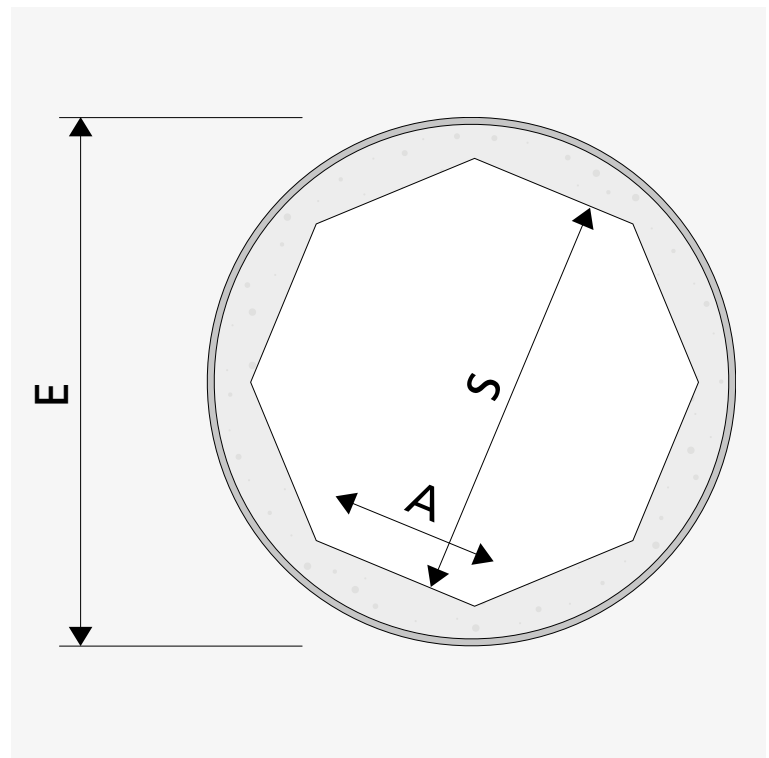

Dimensions

Type	Exterior dia. E mm	S mm	A mm	Weight kg/m	Concrete consumption m ³ /m
231/96	257	231	96	3.50	0.03
277/115	307	277	115	4.60	0.06
323/134	359	323	134	5.40	0.10
370/153	410	370	153	6.30	0.23
554/229	614	554	229	11.40	0.41
739/306	818	739	306	21.80	0.41

RAPIDOBAT® Custom shapes

For creative reinforced concrete columns

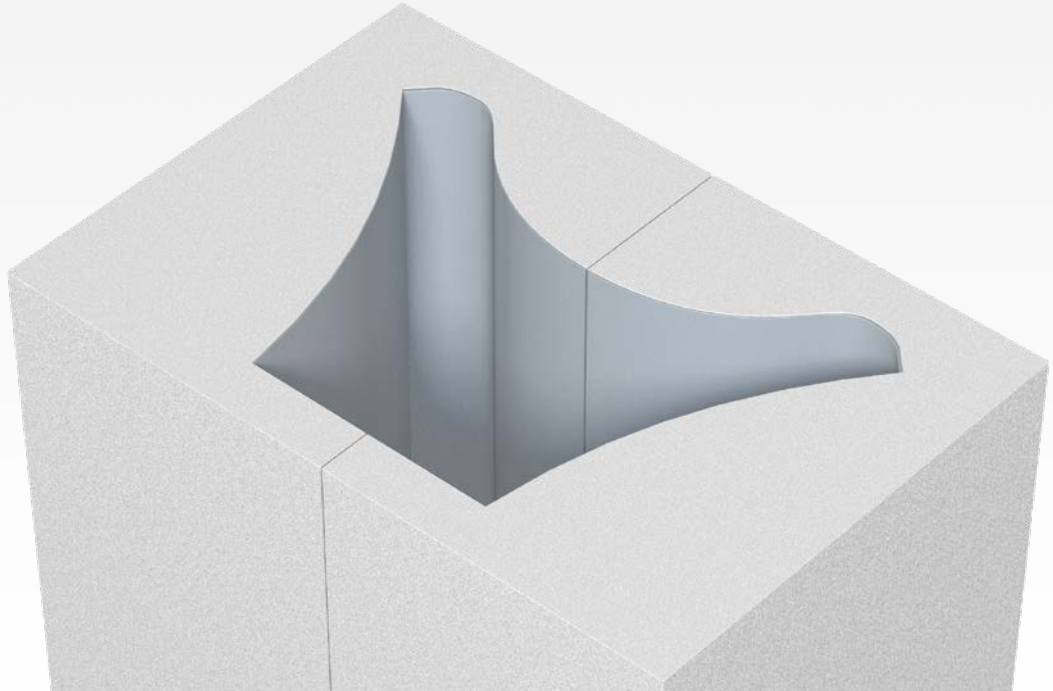

The product

Any and all creative and complex custom shapes are possible. From conical columns to ellipses or L-shaped columns. We can make the formwork according to your drawings and specifications. Just ask us!



Benefits

- Established manufacturer of top-quality column formwork for over 20 years
- Recyclable material
- Retains shape even in driving rain



Notes

An integrated ripcord makes it quick and easy to strip the formwork from the reinforced concrete column. The formwork tube can then be used to protect the newly cured concrete.

Technical information / variants

Formwork for custom shapes

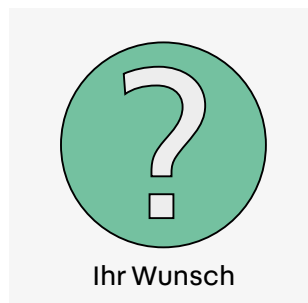
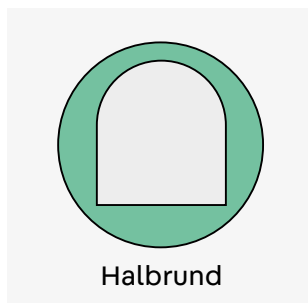
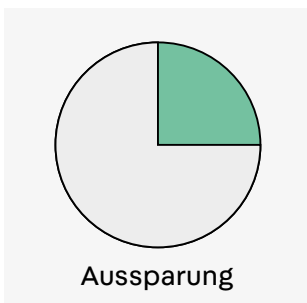
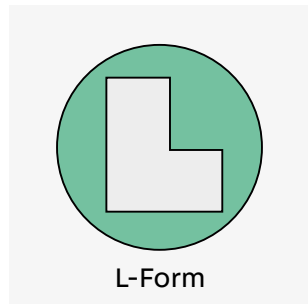
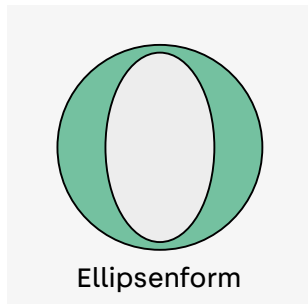
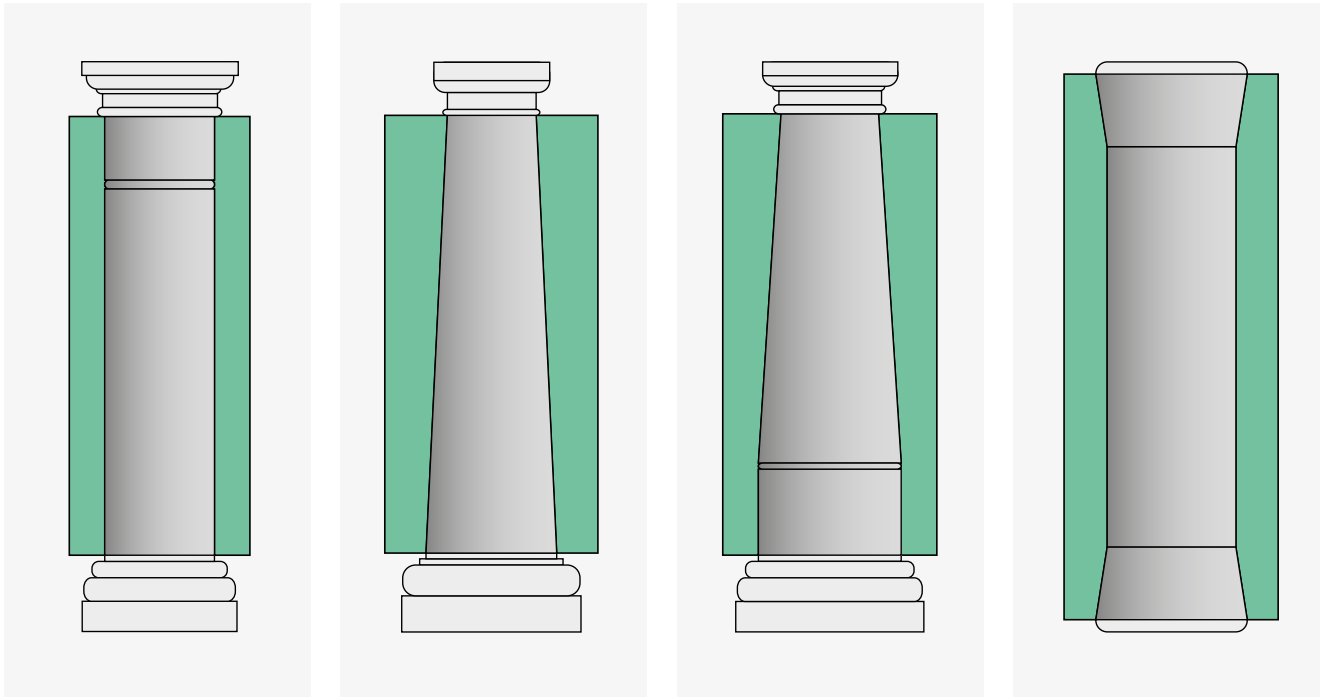

Notes

Special shapes available on request and only after consultation.

RAPIDOBAT® Capitals and bases

For enhancing the appearance of reinforced concrete columns



The product

The two-part capital and base shuttering elements are made from rigid polystyrene foam. There is virtually no limit to the column design options made possible by using these formwork elements. These shuttering elements are a quick and cost-effective solution for building stylish new buildings and structures and also for restoring historical buildings. The formwork is coated with a gel-like release agent which makes it easy to remove.

Installation

To achieve the best concrete surface finish, the base should be cast first. Then the formwork tube is fixed in place on the cast base. Next, the capital shuttering is positioned accurately on top of the formwork tube and fixed in place. Finally, the capital is cast.



Benefits

- Low-cost production of capitals and bases
- Huge variety of shapes
- Short stripping time
- Can be used multiple times if handled with care
- Wide range of accessories, such as shuttering elements and abacuses

Technical information

Capital type	H mm	H1 mm	S mm	S1 mm	A mm
Rome	50	150	50	60	Column dia. + 120
Parma	50	150	50	90	Column dia. + 180
Palermo	50	150	100	110	Column dia. + 220

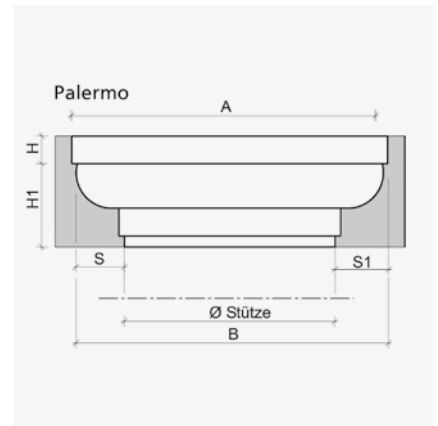
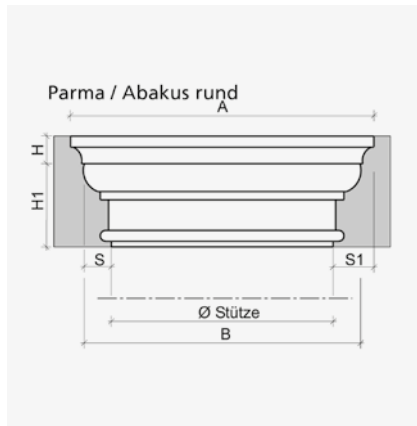
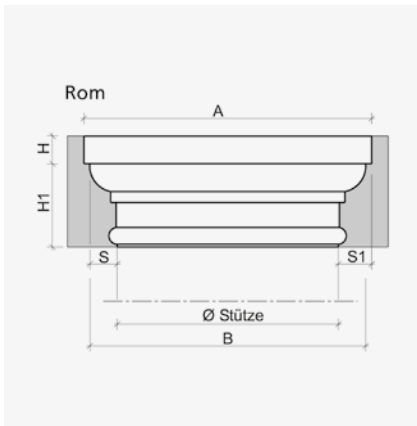

Base type	H mm	H1 mm	S mm	S1 mm	A mm
Messina	200	100	80	90	Column dia. + 180
Verona	200	100	70	80	Column dia. + 160
Ancona	200	100	55	65	Column dia. + 130

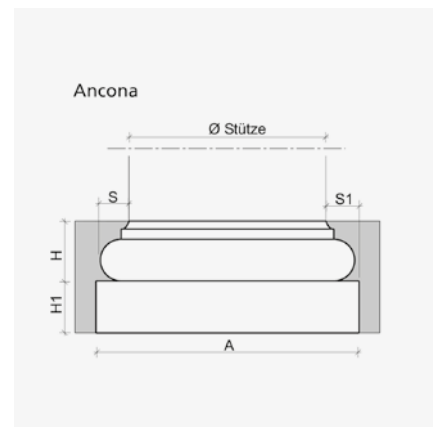
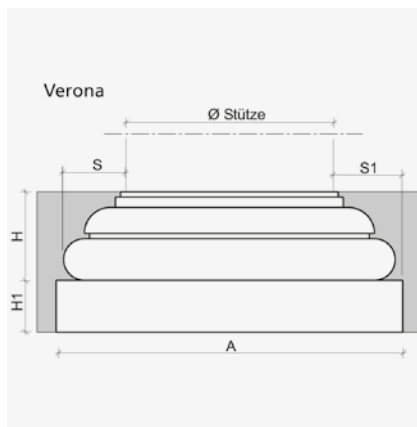
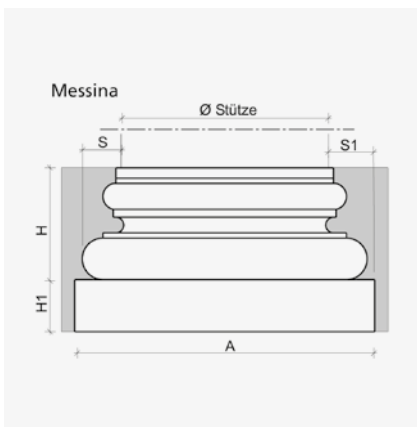

Only a few of the many capitals and bases available for RAPIDOBAT® formwork tubes are shown here. Do not hesitate to ask us about further options.

RAPIDOBAT® Accessories

For a firm hold during assembly

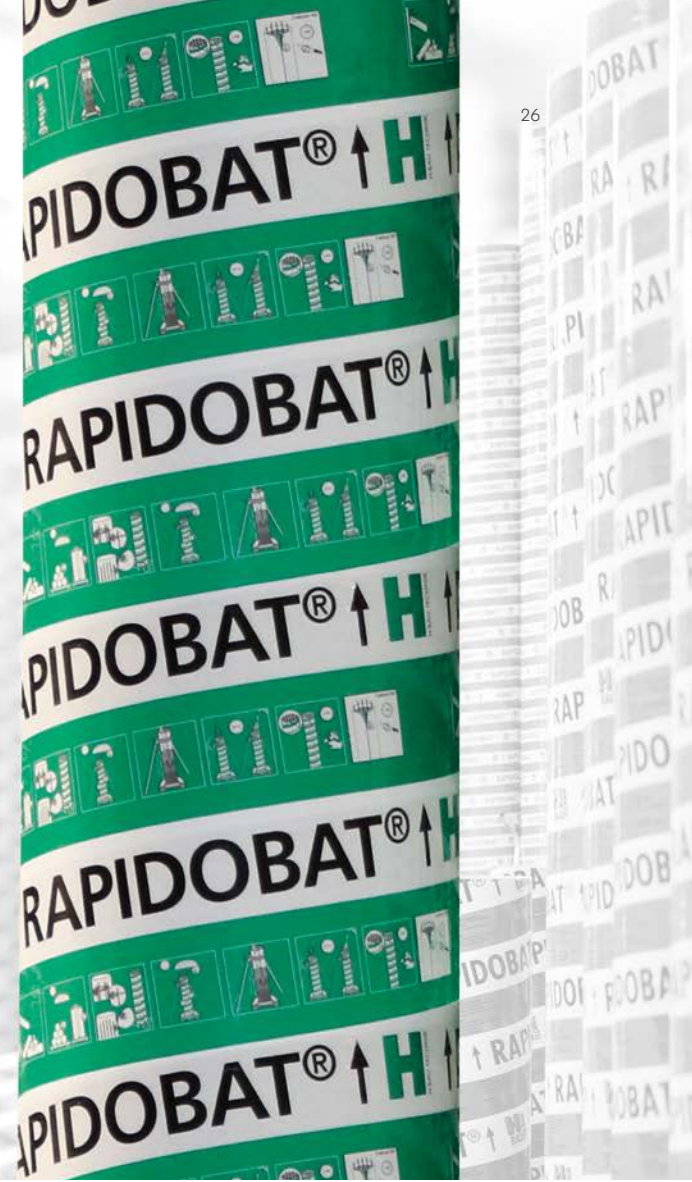

The product

Our tried-and-tested fastening elements have been specially developed for use with RAPIDOBAT® formwork tubes and provide a firm hold during the casting process.

Area of application

RAPIDOBAT® accessories make it easy to set up, cast and strip the formwork tubes. Construction progress is rapid and economical.



Benefits

- Suitable for all dimensions
- Some are continuously adjustable
- Can be used multiple times if handled with care

Technical information

RAPIDO clamps

Usage:

- Fixing the upper sections of Rapidobat® formwork tubes
- Intermediate bracing for longer lengths of formwork tube
- Vertical alignment

Type selection depends on:

- Formwork tube diameter
- Local conditions
- Specific requirements of the application

RAPIDO clamp type M



- Adjustable steel sleeve
- Anchors for aligning with tension and compression struts
- Dia. 250-1200mm
- 5 adjustable sizes

RAPIDO clamp type D



- Adjustable strap
- Anchors for aligning with tension and compression struts
- Holders with soft supports
- Dia. 200-1200mm

RAPIDO-Fix



- Sheet metal mounting aids for aligning RAPIDOBAT® Square and Rectangle
- For all dimensions
- Set includes 2 units

Release agent for capitals and bases



- Gelatinous release agent
- Consumption approx. 0.65 l/standard element

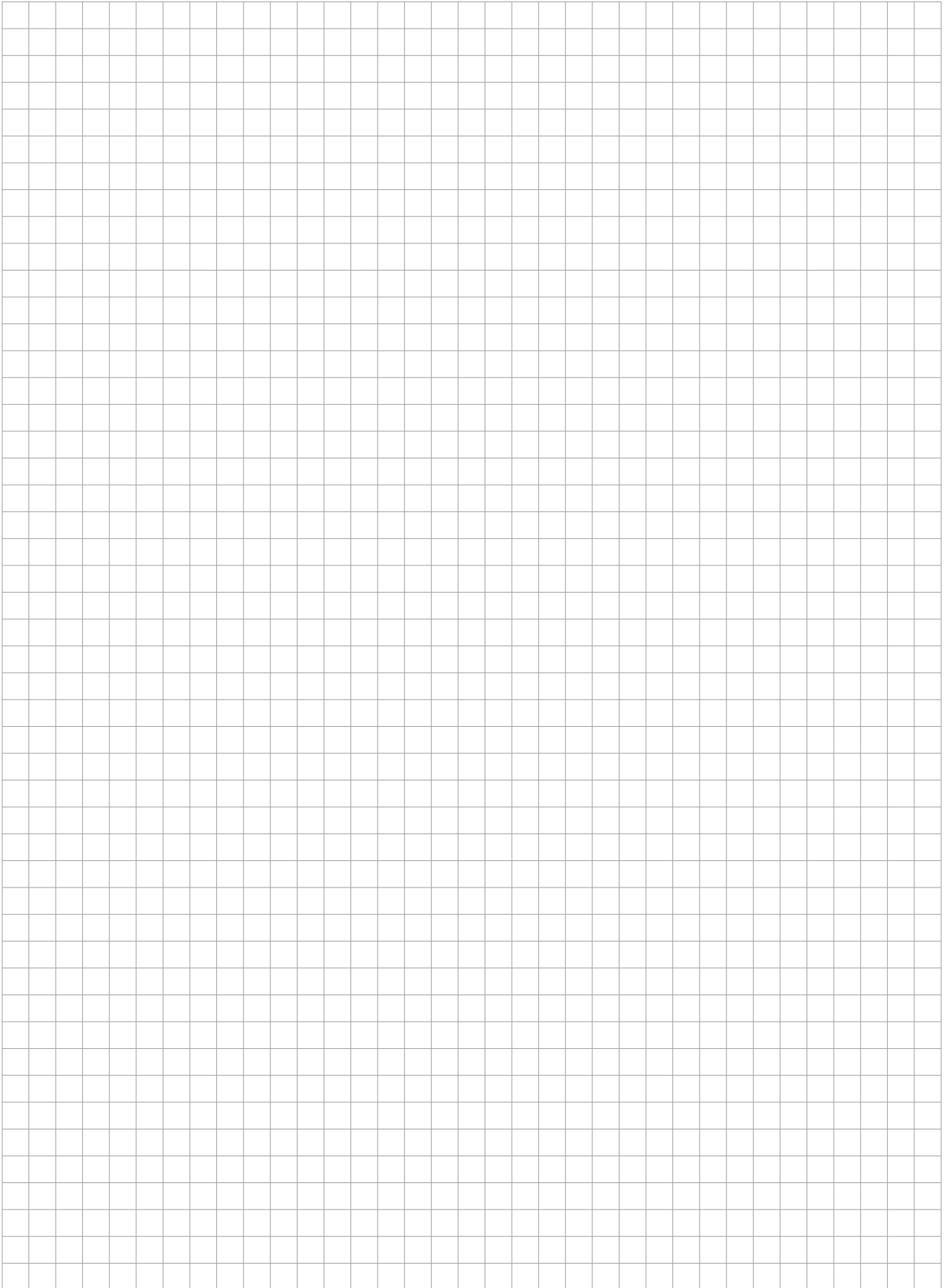

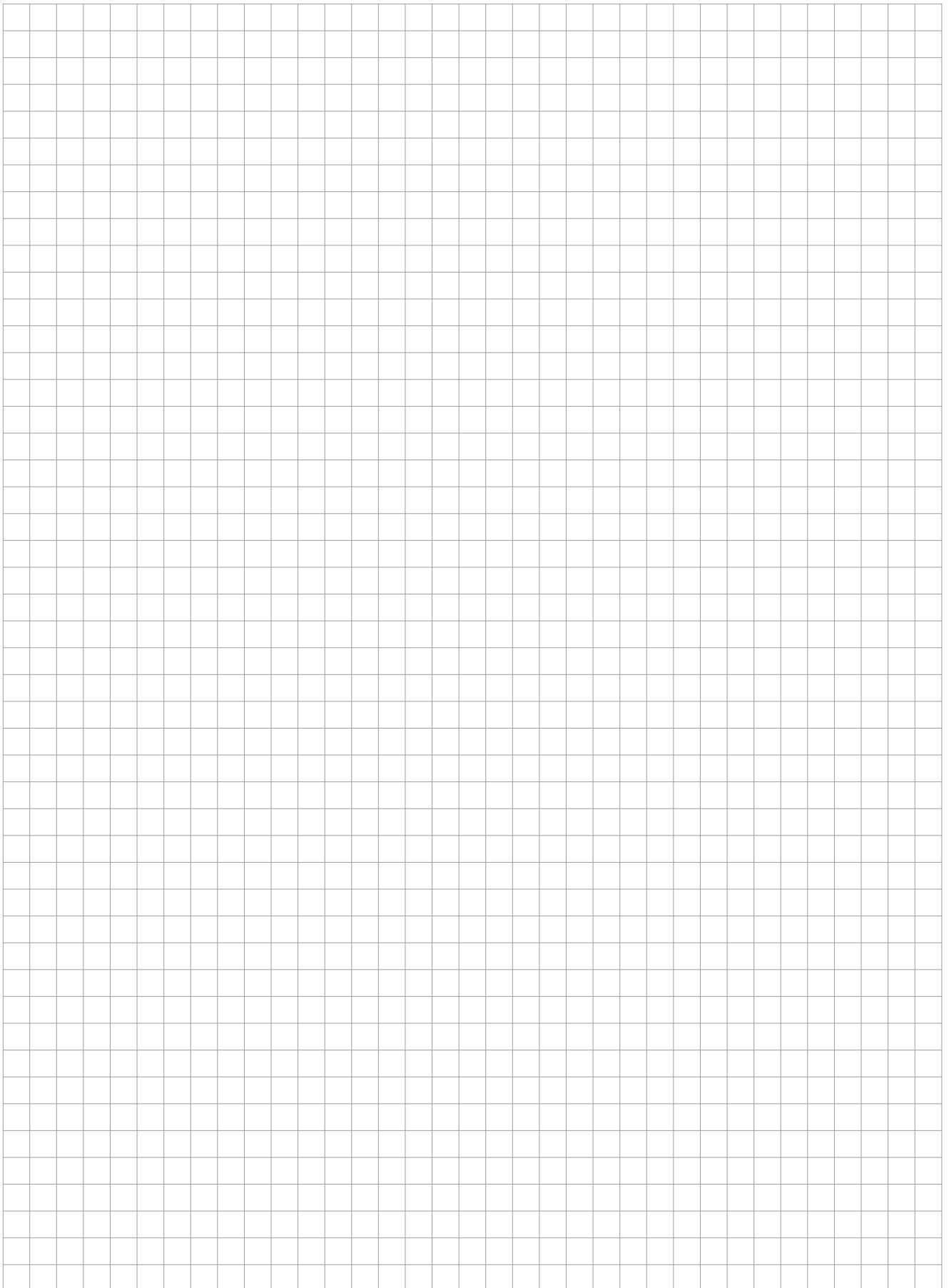

Our synergy concept for you

With us, you benefit from the collective experience of three established manufacturers who combine their products and expertise to form a truly comprehensive range. This is the PohlCon synergy concept.



Full-service consulting

Our extensive network of advisors is available to answer all your questions about our products on site. You will enjoy personal support from our qualified staff right from the planning stage through to construction.



Digital solutions

Our digital services give you targeted planning assistance when using our products. We provide tailor-made planning support from tender specifications to CAD details, BIM data and modern software solutions.



Seven fields of application

We think in terms of holistic solutions. That is why we have grouped our products into seven fields of application in which you can benefit from the synergy of the PohlCon product range.

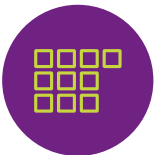

Ten product categories

The products are divided into ten product categories to help you find the right product from our extensive range even faster. This allows you to navigate unerringly through our products.



Custom solutions

Can't find a series product on the market that is suitable for your project? We master extraordinary challenges by harnessing the many years of expertise in the field of custom solutions of our three manufacturer brands. In this way, we can build unique construction projects together.



All rights reserved. This document may not be reprinted or electronically reproduced without our prior written permission. Content subject to technical change without notice. Errors and omissions excepted. The publisher shall assume no liability, irrespective of the legal grounds for this. This document supersedes all previous documentation.

PohlCon GmbH

Nobelstr. 51
12057 Berlin, Germany

T +49 30 68283-04
F +49 30 68283-383

www.pohlcon.com