

JORDAHL[®] JBA support corbel

Technical information



the \mathbb{R}^n space. The \mathbb{R}^n space is a vector space over the real numbers, and the \mathbb{R}^n space is a vector space over the real numbers.

The \mathbb{R}^n space is a vector space over the real numbers, and the \mathbb{R}^n space is a vector space over the real numbers.

The \mathbb{R}^n space is a vector space over the real numbers, and the \mathbb{R}^n space is a vector space over the real numbers.

The \mathbb{R}^n space is a vector space over the real numbers, and the \mathbb{R}^n space is a vector space over the real numbers.

The \mathbb{R}^n space is a vector space over the real numbers, and the \mathbb{R}^n space is a vector space over the real numbers.

The \mathbb{R}^n space is a vector space over the real numbers, and the \mathbb{R}^n space is a vector space over the real numbers.

The \mathbb{R}^n space is a vector space over the real numbers, and the \mathbb{R}^n space is a vector space over the real numbers.

The \mathbb{R}^n space is a vector space over the real numbers, and the \mathbb{R}^n space is a vector space over the real numbers.

The \mathbb{R}^n space is a vector space over the real numbers, and the \mathbb{R}^n space is a vector space over the real numbers.

The \mathbb{R}^n space is a vector space over the real numbers, and the \mathbb{R}^n space is a vector space over the real numbers.

The \mathbb{R}^n space is a vector space over the real numbers, and the \mathbb{R}^n space is a vector space over the real numbers.

Table of contents

Introduction	4	JORDAHL® JBA support corbel	8	Service	18
<hr/>		<hr/>		<hr/>	
PohlCon synergy concept	4	Versions	9	Our synergy concept for you	18
<hr/>		<hr/>			
JORDAHL GmbH	6	Profile sizes and lengths	10		
		<hr/>			
		Installation and mounting instructions	10		
		<hr/>			
		Installation accessories	12		
		<hr/>			
		Dimensioning the system	14		
		<hr/>			
		JORDAHL® EXPERT JBA support corbel software	15		
		<hr/>			
		JORDAHL® EXPERT JTA anchor channel software	16		

JORDAHL® JBA support corbel



JORDAHL® JBA support corbels are used in façade construction to fasten prefabricated elements made of reinforced concrete. They are used in particular for lattice and strip façades, for which exposed concrete elements, e.g. parapet slabs, are frequently installed in front of the storey ceilings. If the parapet slab is located above the uppermost or below the lowermost ceiling slab, it is also called a reverse panel bar or apron.

The support corbels each consist of a top hat profile, at the head of which there are four B500B reinforcement bars or optionally B500B NR in the case of a thinner concrete cover, which are used for integration into the parapet slab. As a rule, two support corbels are used per parapet slab such that the load is distributed symmetrically. This ensures simple installation and even distribution of the forces on the support corbels.

JORDAHL® JBA support corbels are made of high-quality Lean Duplex stainless steel of strength class S460 and are categorised under corrosion resistance class (CRC) III. An efficient design procedure allows the strength of the stainless steel used to be fully utilised.

The position of the thrust bearing (sliding bearing A at the front edge of the ceiling slab) is defined by a load distribution plate. The tension bearing (fixed bearing B approx. 0.5 m behind the front edge of the ceiling slab) is fixed in the reinforced concrete of the ceiling slab.

JORDAHL® JTA anchor channels with screws are the ideal fastening elements, as this guarantees safe, quick and high-quality construction. Alternatively, dowels can be installed as fasteners, which must be approved and suitable.

If a JORDAHL® JTA anchor channel with screw is chosen as the fastening element, it is possible to compensate for tolerances at right angles to the support corbel. Tolerances in the axis of the support corbel are compensated via a toothed slotted hole in which the innovative JORDAHL® JXS toothed locking plate is securely fastened.

Versions

Standard and reversed panel bar

JORDAHL® JBA support corbels are available in standard and reversed panel bar configurations. In the standard version, the reinforcement bars for connecting the reinforced concrete element point upwards, while in the reversed version they point downwards. In custom designs, the reinforcement bars can also be welded on at variable heights.

The JORDAHL® JBA-Set support corbel sets include the accessories required for installation.



JBA-N: Standard version



JBA-A: Reversed version

Support corbel types and accessories for installing standard and reversed panel bar versions

Support corbel type	JBA-1	JBA-2, JBA-3, JBA-4	JBA-5, JBA-6, JBA-7, JBA-8
Accessory set	JBA-Set 1	JBA-Set 2-4	JBA-Set 5-8
Toothed locking plate	JXS-D13	JXS-D17	JXS-D21
Horseshoe shim	JVS-40/3-13	JVS-65/4-17	JVS-80/8-21

Standard and reversed panel bar, adjustable

Both standard and reversed panel bar versions are also available in adjustable versions. In this case, the JORDAHL® JBA support corbels can be raised or lowered at the thrust bearing (front sliding bearing A) by means of the JORDAHL® JGW levelling pins. Do not carry out the adjustment under load to avoid cold welding.

The installation accessories for this design type can be found in the JORDAHL® JBA-SetJ support corbel sets.



JBA-NJ: Standard version, adjustable



JBA-A: Reversed version, adjustable

Support corbel types and accessories for installing standard and reversed panel bar versions, adjustable

Support corbel type	JBA-1	JBA-2	JBA-3	JBA-4	JBA-5, JBA-6	JBA-7, JBA-8
Accessory set	JBA-SetJ 1	JBA-SetJ 2	JBA-SetJ 3	JBA-SetJ 4	JBA-SetJ 5-6	JBA-SetJ 7-8
Toothed locking plate	JXS-D13	JXS-D17	JXS-D17	JXS-D17	JXS-D21	JXS-D21
Horseshoe shim	JVS-40/3-13	JVS-65/4-17	JVS-65/4-17	JVS-65/4-17	JVS-80/8-21	JVS-80/8-21
Square bearing plate	JVL-40/3-8	JVL-65/4-8	JVL-65/4-8	JVL-65/4-8	JVL-80/8-8	JVL-80/8-8
Levelling pin ¹⁾	JGW M16x50	JGW M16x50	JGW M20x55	JGW M24x60	JGW M27x70	JGW M30x80
Adjustment range for vertical tolerance compensation	25 mm	25 mm	25 mm	25 mm	30 mm	30 mm

¹⁾ Use a suitable tool to turn the slotted JORDAHL® JGW levelling pin for adjustment.



Example order for accessory set

Type/version Profile size

JBA-SetJ	-	4
----------	---	---

Profile sizes and lengths

JORDAHL® JBA support corbels are available in eight profile sizes (JBA-1 to JBA-8). Each profile size is available in different lengths, which are individually adapted to the structurally necessary installation situations and the existing circumstances. The free Jordahl Expert design software for the JBA support corbel is available for this purpose. For an initial pre-dimensioning, there are standard lengths that can be selected depending on the spacing e (0-200 mm) (other lengths upon request).

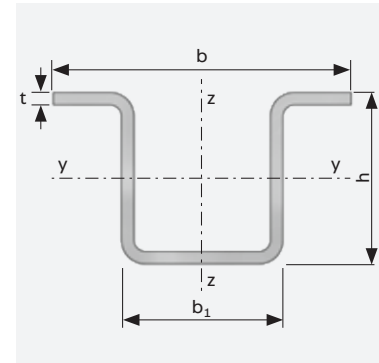

Profile sizes	JBA-1	JBA-2	JBA-3	JBA-4	JBA-5	JBA-6	JBA-7	JBA-8
h mm	44.0	48.0	54.0	66.0	70.0	83.0	84.0	85.0
b mm	74.0	84.0	94.0	122.0	122.0	144.0	148.0	144.0
b₁ mm	40.0	45.0	51.0	65.0	66.0	77.0	80.0	80.0
t mm	3.0	3.0	4.0	4.0	5.0	5.0	6.0	8.0
l_z mm ⁴	178,101	257,679	477,422	1,032,198	1,310,667	2,184,304	2,708,518	3,327,721
l_y mm ⁴	118,337	161,810	294,567	591,391	814,274	1,405,749	1,589,013	1,991,750

Profile lengths ¹⁾	JBA-1	JBA-2	JBA-3	JBA-4	JBA-5	JBA-6	JBA-7	JBA-8
0-45 mm	400	450	500	550	550	600	650	700
50-100 mm	450	500	550	600	600	650	700	750
105-140 mm	500	550	600	650	650	700	750	800
145-200 mm	600	650	700	750	750	800	850	900

¹⁾ Standard lengths in mm for spacing e (see page 11, section A-A)

Installation and mounting instructions

Requirements and installation in ceiling slabs

Each parapet slab is anchored to the ceiling slab with two JORDAHL® JBA support corbels. The ceiling slabs must be made of concrete of at least concrete strength class C20/25. The ceiling slabs can be planned with recesses to allow for recessed installation (see page 11, section B-B). In this case, the reduced anchorage depth/component thickness must be taken into account when dimensioning the fastening element (dowel or Jordahl JTA anchor channel).

For constraint-free support, the lateral mobility of the support corbels must be ensured by means of a separator when grouting or setting in concrete. For this purpose, easily compressible materials such as Styrofoam® or Armaflex® should be chosen.

Recess dimensions in ceiling slabs

	JBA-1	JBA-2	JBA-3	JBA-4	JBA-5	JBA-6	JBA-7	JBA-8
B mm	200	200	200	225	225	250	250	250
H mm	80	80	90	110	110	120	120	120

Installation in parapet slabs

Two JORDAHL® JBA support corbels are embedded in the concrete of each parapet slab. The parapet slabs made of reinforced concrete must be of at least class C30/37. They must be dimensioned separately according to EN 1992, except for the connection of the support corbel in the area of the clamped support. The distance between the front edge of the ceiling slab and the inner edge of the façade slab is defined by dimension e . To ensure accurate positioning of the façade slab, the installation position of the support corbel (upper edge of the façade slab to the fastening plane) must be

reduced by the material thickness of the front square plate, i.e. by the dimension Δh (lower edge of the support corbel to the fastening plane). If additional vertical adjustment is required, the installation position can be reduced by the bracket value Δh . In this case, however, the fastening element (dowel or Jordahl screw) must be dimensioned and verified by engineers for offset mounting with bending forces. All other necessary values can be taken from the following table.

Design data for parapet slab

	JBA-1	JBA-2	JBA-3	JBA-4	JBA-5	JBA-6	JBA-7	JBA-8
$c_{nom,i}$ mm	25	25	25	25	25	25	25	25
$c_{nom,e}$ mm	35	35	35	35	35	35	35	35
i mm	40	40	50	60	70	75	90	90
f_{min} mm	100	100	110	120	130	135	150	150
t_e mm	70	72	82	92	102	108	123	125
Φ mm	10	10	12	14	14	16	16	20
l_{con} mm	360	360	450	510	510	580	580	720
l_{over} mm	76	80	80	80	88	88	88	88

Notes: $c_{nom,i}$ / $c_{nom,e}$: Interior/exterior concrete cover when used in building construction, to be adjusted when used under other conditions; Φ / l_{con} : Diameter/length of connection reinforcement; i : Spacing of connection reinforcement (exterior-exterior); f_{min} : Minimum thickness of parapet slab; t_e : Minimum embedding depth in parapet slab; l_{over} : Distance between middle axis of toothed slotted hole and end of support corbel

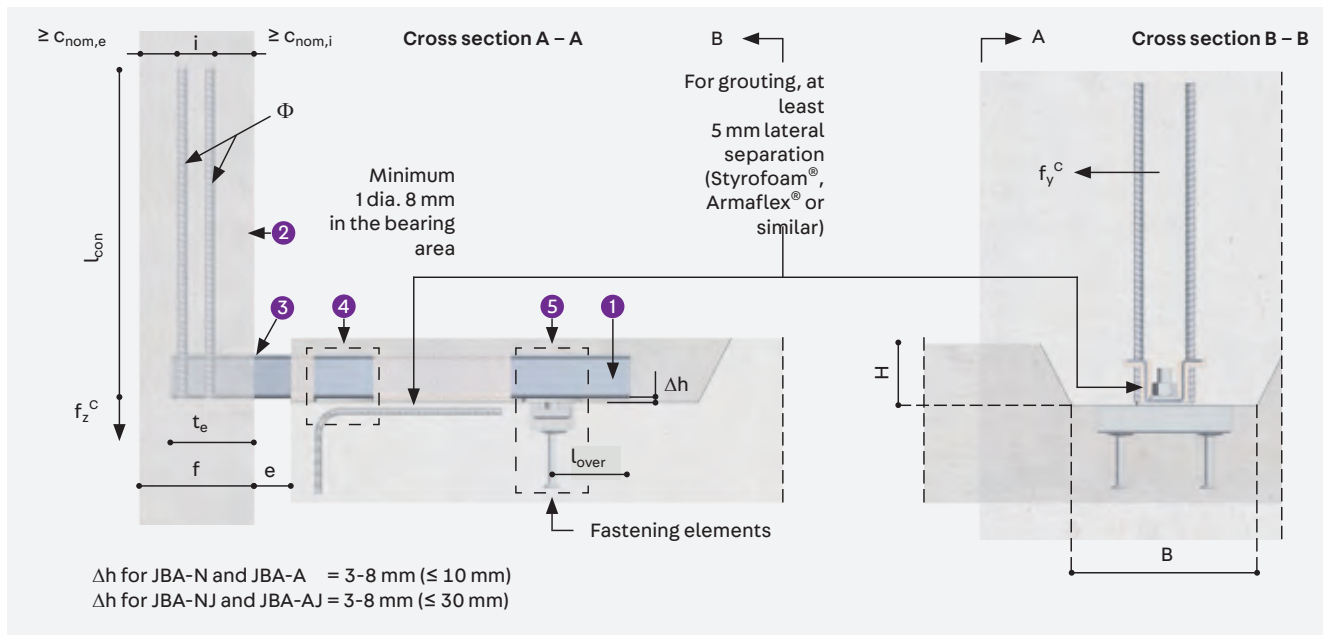

- 1 Support corbel
- 2 Parapet slab
- 3 Clamped support
- 4 Front thrust bearing
- 5 Rear tension bearing

Example order for JBA support corbel

Type/version	Profile size	Length	Spacing
JBA-NJ	4	600	75

Installation accessories

All accessories for installation can also be ordered individually. As lining under it, additional JORDAHL® JVS horseshoe shims for the

tension bearing and JORDAHL® JVL square bearing plates for the thrust bearing can be ordered to raise the JORDAHL® JBA support corbel overall.

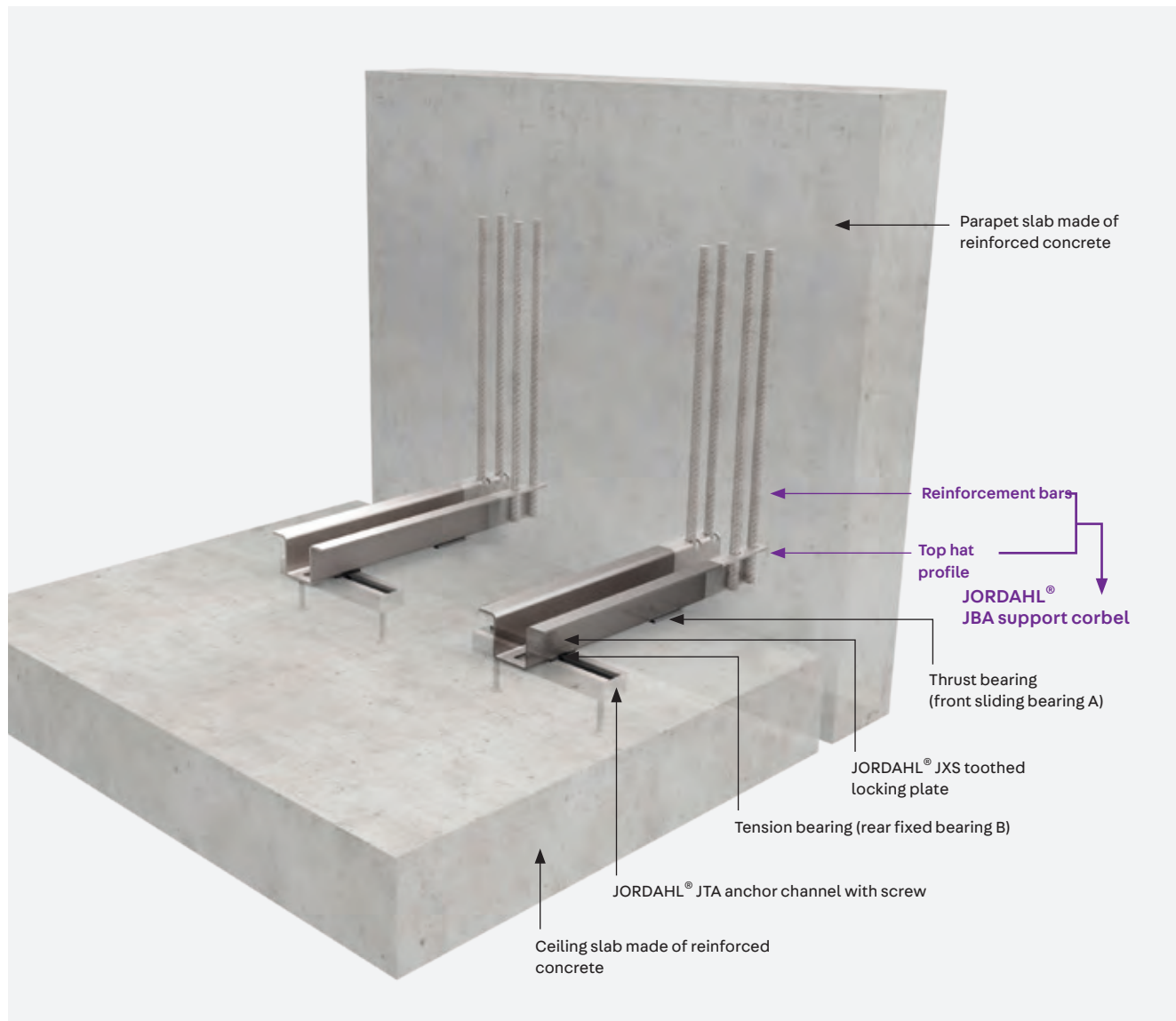

Materials

- Lean Duplex stainless steel of strength class S460
- Reinforcing steel B500B



JORDAHL® JXS toothed locking plate, top side



JORDAHL® JXS toothed locking plate, bottom side

	Material thickness	JBA-1	JBA-2, JBA-3, JBA-4	JBA-5, JBA-6, JBA-7, JBA-8
Horseshoe shim	3 mm	JVS-40/3-13	JVS-65/3-17	JVS-80/3-21
	4 mm	JVS-40/4-13	JVS-65/4-17	JVS-80/4-21
	6 mm	JVS-40/6-13	JVS-65/6-17	JVS-80/6-21
	8 mm	JVS-40/8-13	JVS-65/8-17	JVS-80/8-21
Square bearing plate	3 mm	JVL-40/3-8	JVL-65/3-8	JVL-80/3-8
	4 mm	JVL-40/4-8	JVL-65/4-8	JVL-80/4-8
	6 mm	JVL-40/6-8	JVL-65/6-8	JVL-80/6-8
	8 mm	JVL-40/8-8	JVL-65/8-8	JVL-80/8-8

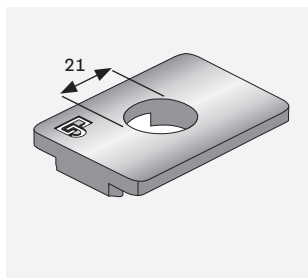

Example: JORDAHL®
JXS-D21 toothed locking plate

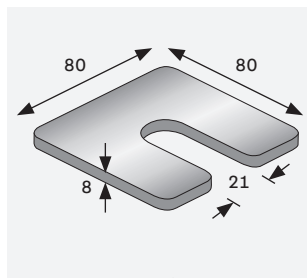

Example: JORDAHL®
JVS-80/8-21 horseshoe shim

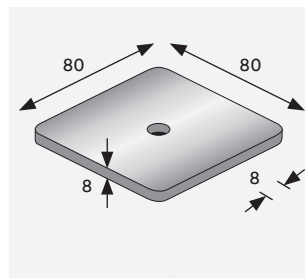

Example: JORDAHL®
JVL-80/8-8 square bearing plate

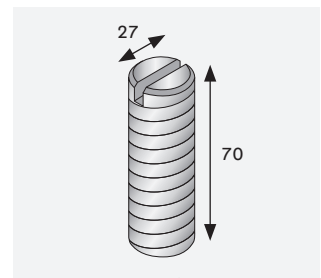

Example: JORDAHL®
JGW M27x70 levelling pin



Example order for individual parts

Toothed locking plate

JXS-D21

Horseshoe shim

JVS-80/8-21

Square bearing plate

JVL-80/8-8

Levelling pin

JGW M27x70

Mounting with JORDAHL® JTA anchor channels

The quickest way to fasten JORDAHL® JBA support corbels at the tension bearing (rear fixed bearing B) to JORDAHL® JTA anchor channels is using screws that can easily be dimensioned with our JORDAHL® EXPERT design program for JTA anchor channels. The screw length depends on the required vertical tolerance compensation, with the required screw

diameter given in the following table. The anchor channels suggested in the table are usually sufficient and can be assumed for tender documents. In the case of an order, a project-specific verification is required. Together with the JORDAHL® JXS toothed locking plate, this makes horizontal tolerance compensation possible.

	JBA-1	JBA-2, JBA-3, JBA-4	JBA-5, JBA-6, JBA-7, JBA-8
Anchor channel, horizontal tolerance compensation¹⁾ (100 mm)	W 40/22-150 K 40/25-150	W 50/30-150 K 50/30-150	W 53/34-200 K 53/34-200
Slotted hole length, horizontal tolerance compensation (80mm)	122 mm	131 mm	146 mm
Screw diameter	M12	M16	M20

¹⁾ For the anchor channel 53/34-200, the horizontal tolerance compensation is 130 mm

Dimensioning the system

The mathematical verification of the system is carried out according to the current Eurocode and is highly complex. Due to the many different forces acting in the system (dead weight of the façade slab, wind load, spar load, additional loads such as railings, etc.) as well as the geometric parameters (arrangement of the anchors, shell spacing, precast part

geometry, etc.), the support corbels cannot be broken down into load levels in tabular form as users will be familiar with from other façade systems. Therefore, the JORDAHL® EXPERT software for JBA support corbels is available for the dimensioning and calculation of the correct corbel.

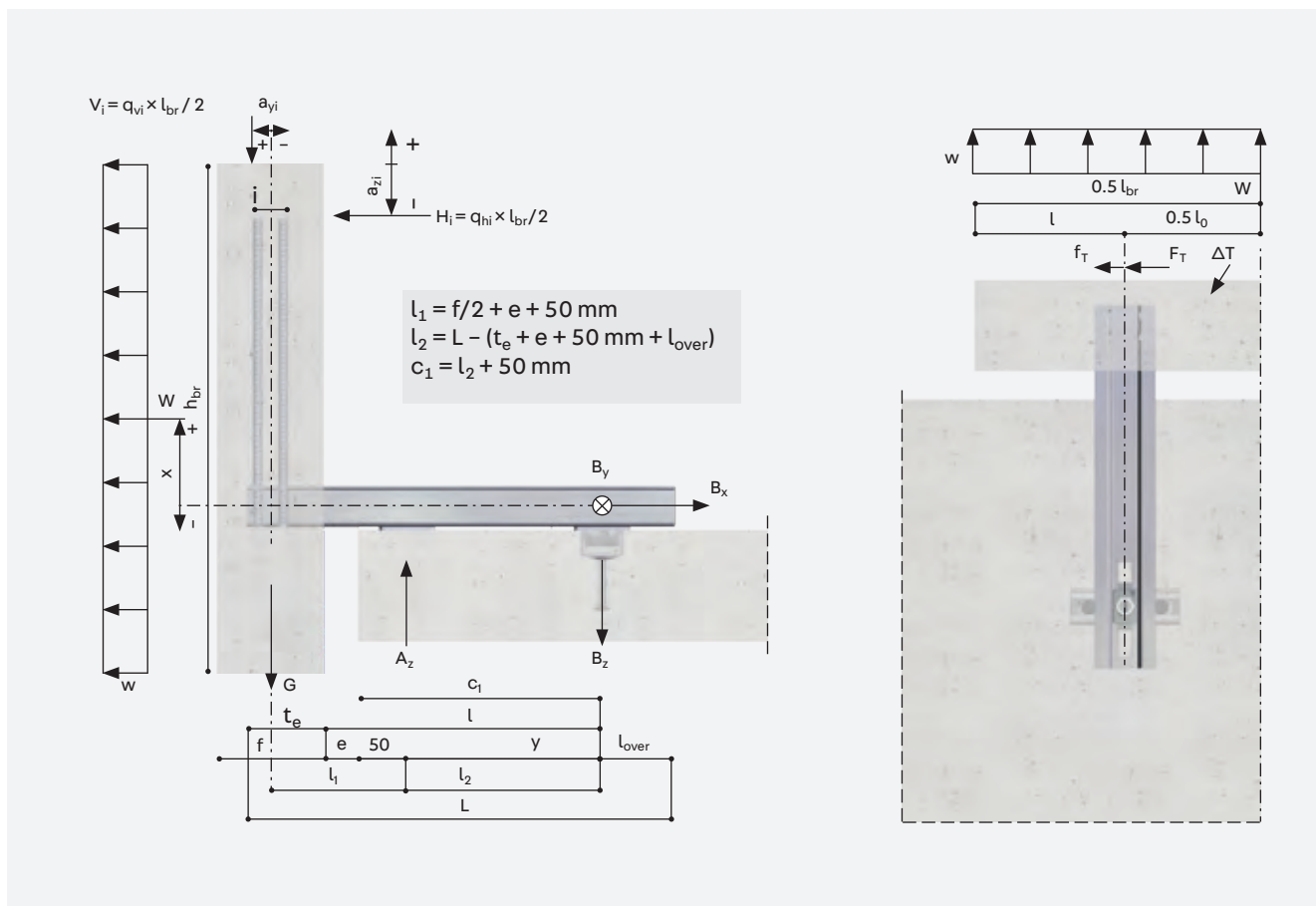

Note

Our JORDAHL® JBA support corbels are not only made out of the latest Lean Duplex stainless steel using state-of-the-art manufacturing technology, but are also dimensioned using a method that makes the best use of the material. This is not only environmentally friendly, but also cost-effective and benefits the customer. Other system manufacturers also promise high load-bearing capacities, but these are sometimes on the uncertain side. The reason for this is that design formulas are used that no longer apply to the profile geometry of the support corbels. Comparative calculations have shown that in some cases this significantly overestimates the load-bearing capacities! For JORDAHL® JBA support corbels, the dimensioning formulas have been correctly derived and checked by an inspection authority, meaning you can rely on the correctness and safety of the design.

JORDAHL® EXPERT JBA support corbel software

- Intuitive operation
- Systematic query of all loads
- Selection of references and standards
- Design results in the form of a verifiable printout
- Generation of parts lists and tender texts
- Type approval S-WUE/130261
- Compatible with Eurocodes (Europe-wide standardised rules for design in the construction industry), as it conforms to EN 1990, EN 1991, EN 1992 and EN 1993



Download for free at
www.pohlcon.com



You can also download the design software for our
 JORDAHL® JTA anchor channels (see page 16) for free.

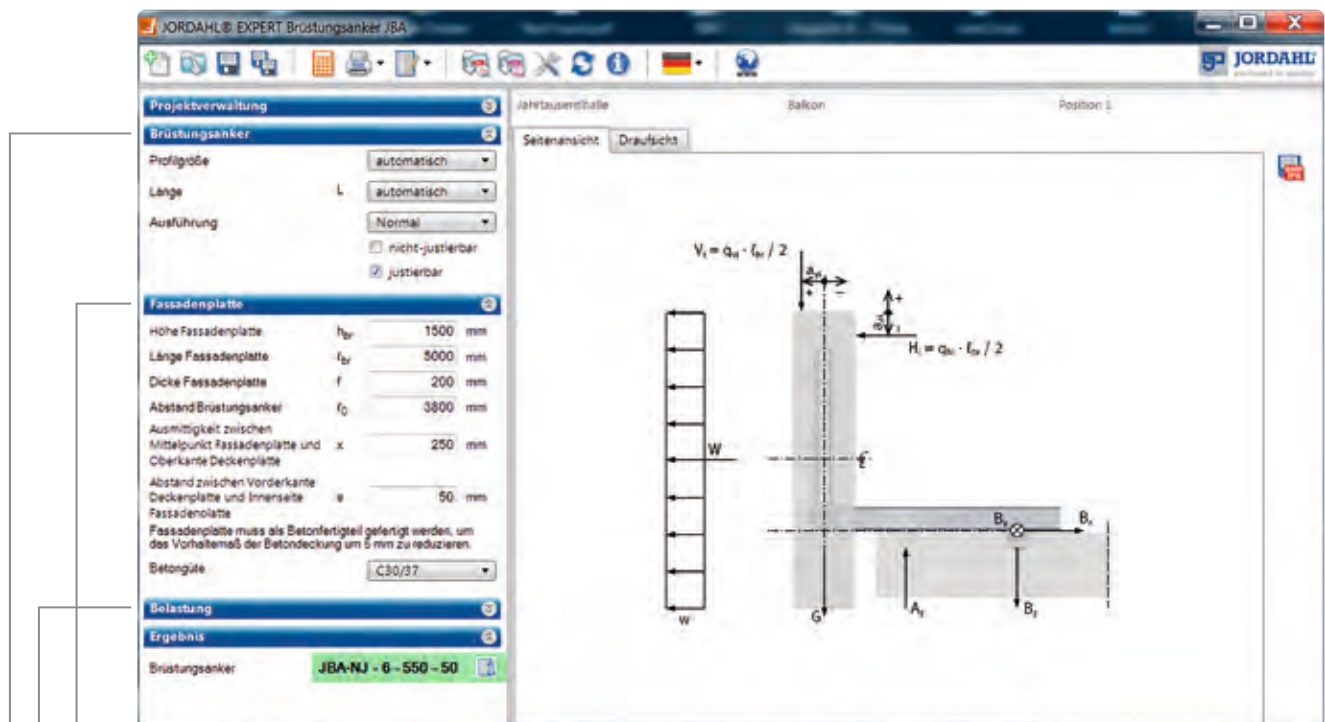

Support corbel

- Profile size
- Length
- Version

Façade slab

- Façade slab height
- Façade slab length
- Façade slab thickness
- Eccentricity
- Spacing

Load

- Wind load
- Temperature stress
- Live loads

Printout of results

Easy-to-understand and transparent design printout containing all test-relevant data as well as tender texts and parts lists, which simplify the ordering of JORDAHL® JBA support corbels.



JORDAHL® EXPERT JTA anchor channel software

Our JORDAHL® EXPERT software makes it a breeze to perform verification calculations for anchoring in concrete using JTA-CE anchor channels. The design is always tailored to the individual anchoring situation, enabling you to optimise the anchoring in terms of technical and economic aspects. Once the input and calculation have been completed, the results of the multiple design are displayed for all available

channel sizes. The design results are output both on the screen and in the form of a verifiable printout. The program is based on European Technical Approval ETA-09/0338. The design software for JORDAHL® anchor channels is adapted to the current EN 1992-4:2018 and other international design methods. Download for free at www.jordahl.de.

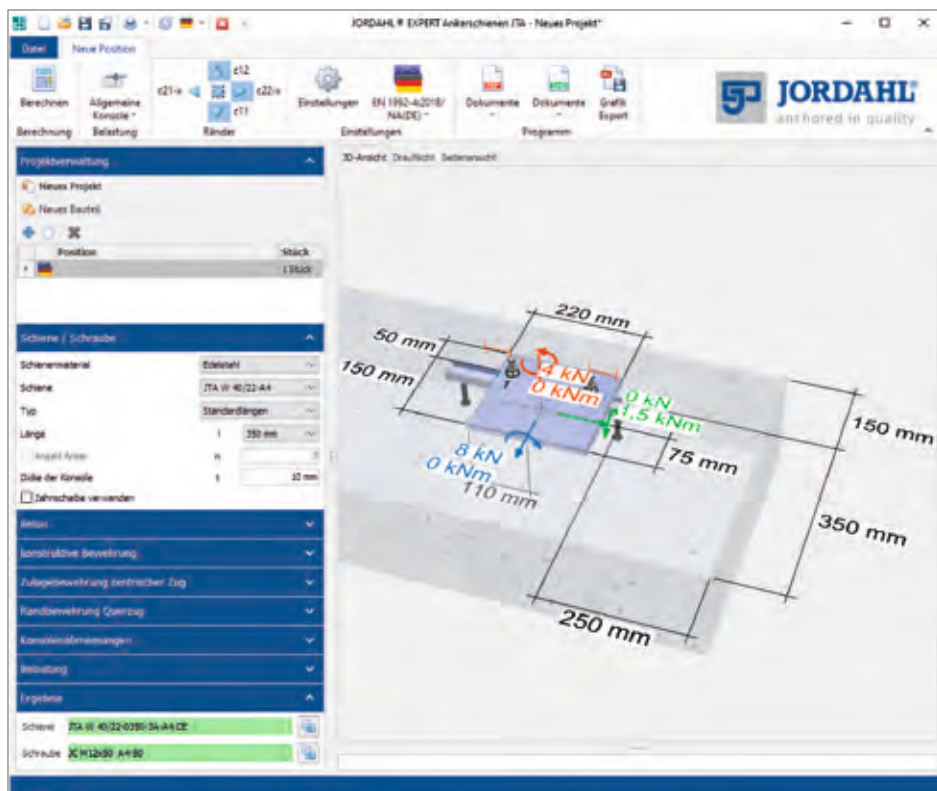

Channel / Screw

- Channel length
- Material; galvanised or stainless steel
- Spaced mounting

Concrete

- Concrete quality
- Slab thickness
- Edge clearances
- Concrete cover

Structural reinforcement

- Normal or unreinforced concrete
- Density of reinforcement

Load

- Input of single and paired loads in individually defined load positions



Printout of results

Easy-to-understand and transparent design printout containing all test-relevant data

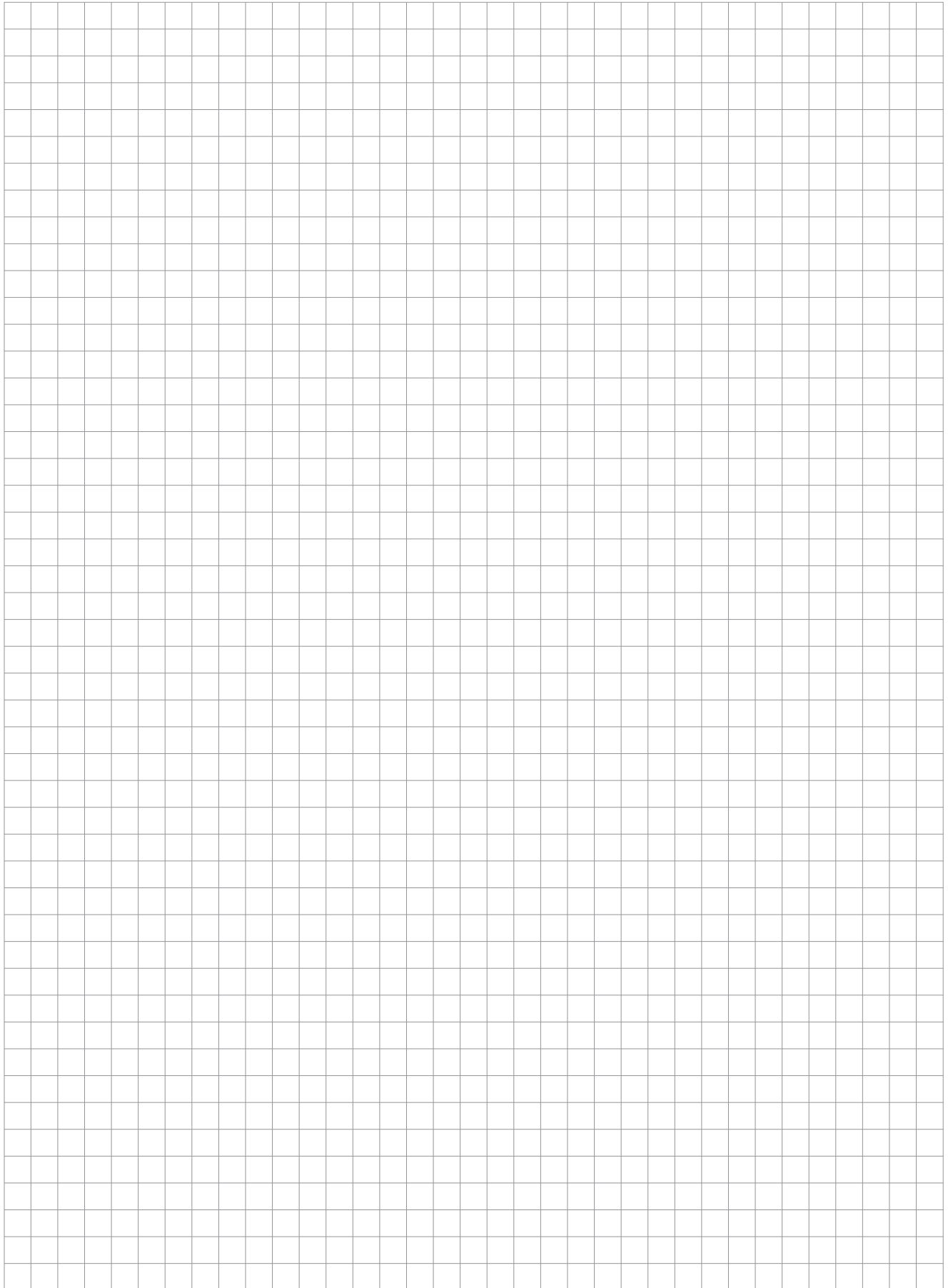

Unser Synergie-Konzept für Sie

Mit uns profitieren Sie von der gesammelten Erfahrung dreier etablierter Hersteller, die Produkte und Expertise in einem umfassenden Angebot kombinieren. Das ist das PohlCon-Synergie-Konzept.



Full-Service-Beratung

Unser weitreichendes Beraternetzwerk steht Ihnen zu allen Fragen rund um unsere Produkte vor Ort zur Verfügung. Von der Planung bis hin zur Nutzung genießen Sie die persönliche Betreuung durch unsere qualifizierten Mitarbeiterinnen und Mitarbeiter.



Digitale Lösungen

Unsere digitalen Angebote unterstützen Sie zielgerichtet in der Planung mit unseren Produkten. Von Ausschreibungstexten über CAD-Details und BIM-Daten bis hin zu modernen Softwarelösungen bieten wir Ihnen maßgeschneiderte Unterstützung für Ihre Planung.



7 Anwendungsfelder

Wir denken in ganzheitlichen Lösungen. Deshalb haben wir unsere Produkte für Sie in sieben Anwendungsfelder zusammengefasst, in denen Sie von der Synergie des PohlCon-Produktportfolios profitieren können.

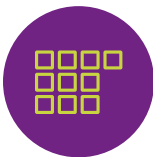

10 Produktkategorien

Um das passende Produkt in unserem umfangreichen Sortiment noch schneller finden zu können, sind die Produkte in zehn Produktkategorien unterteilt. So können Sie zielsicher zwischen unseren Produkten navigieren.



Individuelle Sonderlösungen

Für Ihr Projekt eignet sich kein Serienprodukt auf dem Markt? Außergewöhnliche Herausforderungen meistern wir mit der langjährigen Expertise der drei Herstellermarken im Bereich individueller Lösungen. So realisieren wir gemeinsam einzigartige Bauprojekte.



Errors and technical changes reserved. Reprinting and any electronic reproduction only authorised with our written permission. All previous documents lose their validity with the publication of this printed matter.

PohlCon GmbH

Nobelstrasse 51
12057 Berlin, Germany

T +49 30 68283 - 04
F +49 30 68283 - 383

www.pohlcon.com