

Cable ladders

Assembly instruction

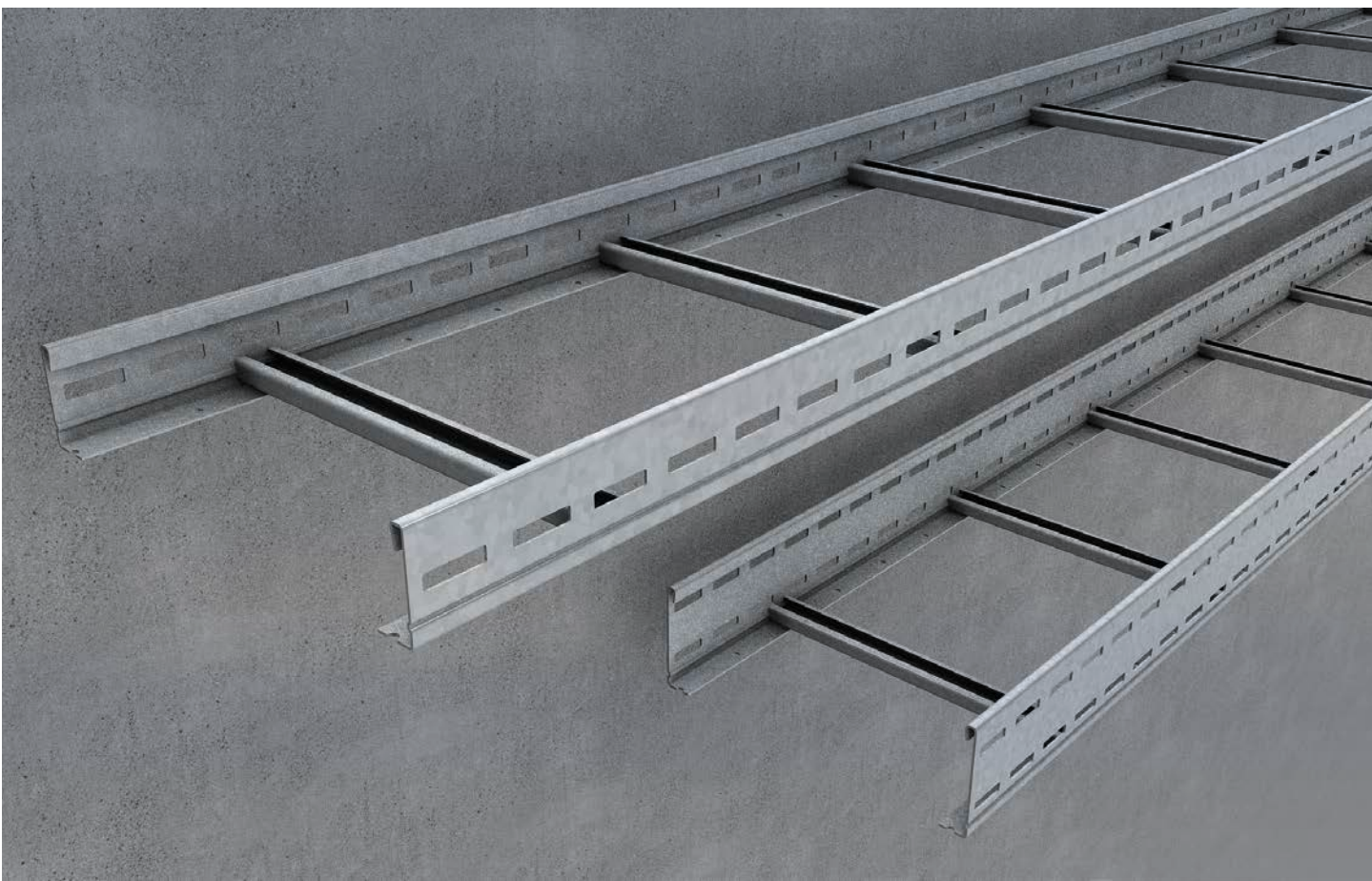

Table of contents

Introduction

Index	3
General notes	4

Assembly steps

Connector assembly	5
Horizontal change of direction	6
Vertical change of direction	8
Accessory assembly	9
Cover assembly	10

Index

Cable ladders

LGG 60/100	Cable ladder, L-profile, height = 60/100 mm
LGGS 60/100	Cable ladder, L-profile, heavy, height = 60/100 mm

Formed parts

LGIB 60/100	Ladder internal bend, height = 60/100 mm
LGAB 60 /100	Ladder external bend, height = 60/100 mm
LGVB 60/100	Ladder vertical bend, height = 60/100 mm
LGA 60/100	Ladder branch, height = 60/100 mm
LGAA 60/100	Ladder attachment branch, height = 60/100 mm
LGK 60/100	Ladder crossing, height = 60/100 mm

Cover

LD	Ladder cover
LDR	Ladder cover with turning bolts
LIBD	Ladder internal bend cover
LIBDR	Ladder internal bend cover with turning bolts
LAD	Ladder branch cover
LADR	Ladder branch cover with turning bolts
LKD	Ladder crossing cover
LKDR	Ladder crossing cover with turning bolts
LD-SW	Storm protection angle - Ladder

Accessories

LGV 60/100	Ladder connector, height = 60/100 mm
LGVB 60/100	Ladder connector, horizontal, height = 60/100 mm
LGVV 60/100	Ladder connector, vertical, height = 60/100 mm
LGTR 60/100	Ladder separating strip, height = 33/80 mm
LGKAB	Ladder drop-out plate
EL	Fibre cement plate
SL 60/100	Protection cap
MP-L	Assembly plate
KZF	Cold zinc paint
KZS	Cold zinc spray

Accessories Fastening

AM16 M6	Channel nut, B 7
FKS 6x10	Slotted cylinder head screws, DIN EN ISO 1580
FRS 8X50	Slotted cylinder head screws, DIN EN ISO 1580
FRSV 6x16	Round-head bolt with short square, DIN 603
FRSV 8x16	Round-head bolt with short square, DIN 603
KLS 8x16	Clamp fastening set (Content: FRSV 8x16, SEMS 8)
SEM 8	Hexagon nut, DIN 934
SEMS 6	Hexagonal nut with flange, DIN EN 1661
SEMS 8	Hexagonal nut with flange, DIN EN 1661
SEMSS 8	Hexagon nut, self-locking, DIN 985
US 8X17	Washer, DIN 125
UVS	Captive washer
KLU	Clamp fastening set (Content: FRSV 6x16, SEMS 6)



Formed parts, covers, accessories and fixing accessories are not included with the cable ladders and must be ordered separately.

General notes

Cable ladders are used to bridge medium to high mounting distances. They are suitable for power cables or cables without deflection. The support structures must be planned by engineers.



The following general instructions must be observed before starting installation:

1. The permissible torque must be observed for all screw connections. (see Tab.: „Selection of screw tightening torques“).
2. The following applies to all formed parts, changes of direction or open ends: The maximum distance of 300 mm between the end of the formed part and support must be observed. (see fig. 1)
3. Carry out cutting and separating work with the utmost care and in compliance with occupational health and safety. (see fig. 2)
4. All cutting and separating points must be galvanised on site after deburring. Cold zinc paint (KZF)/ cold zinc spray (KZS) can be used to repair cut edges or defects for strip/pre-galvanised material (version S). Only KZF may be used for the final/piece galvanised version (version F).
5. Joints must be adequately bolted. Ladders with a side beam height of 60 mm must be bolted once and ladders with a side beam height of 100 mm must be bolted twice per connector end.
6. In the case of high temperature fluctuations, a fixed and loose bearing must be taken into account in the butt joint. (see fig. 3)

Selection of screw tightening torques

Bolt diameter	Strength class Screw (DIN EN ISO 898-1)	Screw tightening torque acc. to VDI 2230 [Nm]
M6	4.6	4
M8	4.6	8
M10	4.6	18
M12	4.6	32
M6	8.8	10
M8	8.8	24
M10	8.8	48
M12	8.8	84

Legend



Wear safety goggles



Wear hearing protection



Observe tightening torque for fastening elements

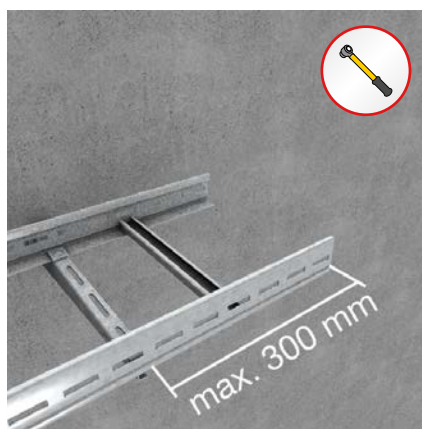

Fig. 1: Support distance to the end of the cable ladder (max. 300 mm)



Fig. 2: Observe occupational safety measures during cutting and separating work

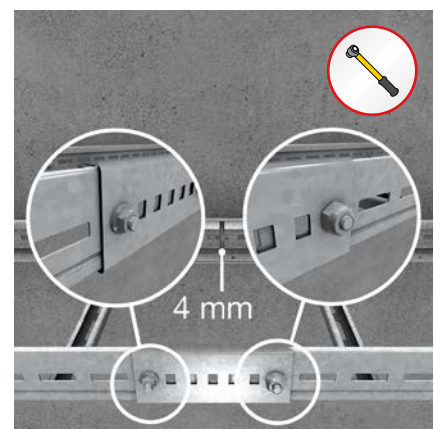
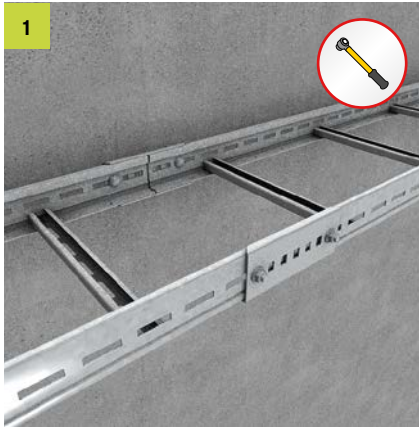

Fig. 3: left: Fixed bearing (KLS 8x16); right: loose bearing (FRSV, SEMSS); Gap dimension 4 mm, tightening torque hand-tight (max. 4 Nm).

Connector assembly

Connection of the cable ladder sides



Ladder connector (LGV)

Push the LGV from the outside onto the beam of the cable ladder and screw it with the clamp fastening (KLS 8x16) for each beam. Insert the connecting ladder and screw it to the LGV. LGV 60

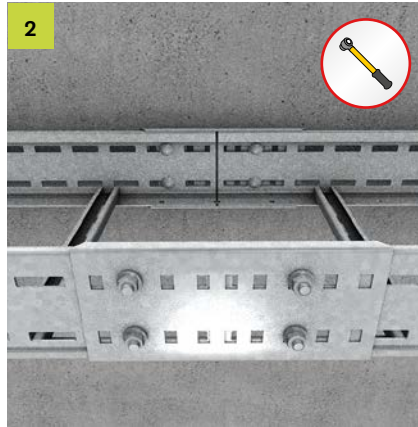

are screwed together once with clamping screw (KLS 8x16) per beam and LGV 100 are screwed together twice (top and bottom) with clamping screw (KLS 8x16) per beam.

Horizontal change of direction

With standard formed parts

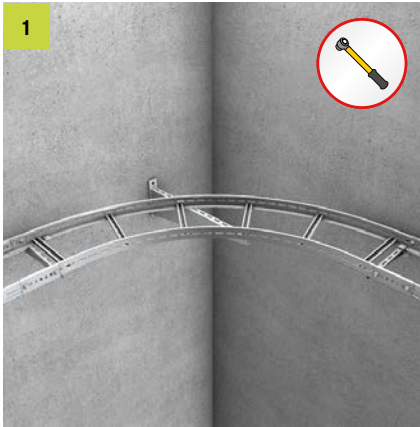

Horizontal bend (LGAB/LGIB)
Mount the ladder connector (LGV)
(see picture ladder connector). Push
in LGAB/LGIB and screw together with
LGV.

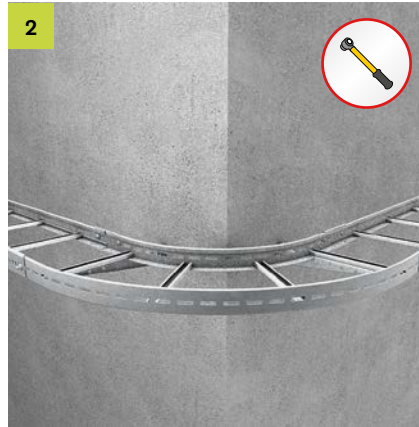

Screw the LGV to the free end of the
horizontal bend with the clamp fas-
tening (KLS 8x16), insert the connecting
ladder and screw it to the LGV.

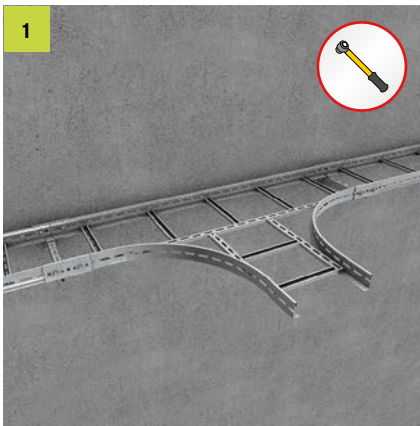

Ladder branch (LGA)
Mount the ladder connector (LGV).
Insert the LGA and screw it to the ladder
connector (LGV).

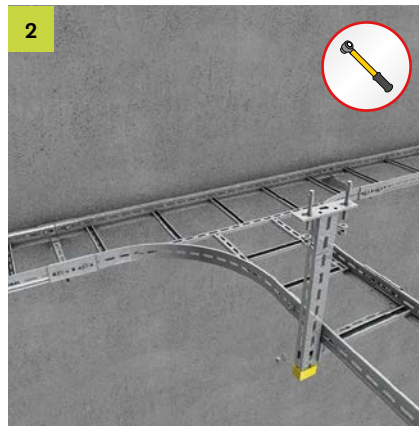

Screw the LGV to the free end of
the branch with the clamp fastening
(KLS 8x16), insert the connecting ladders
and screw them to the LGV.

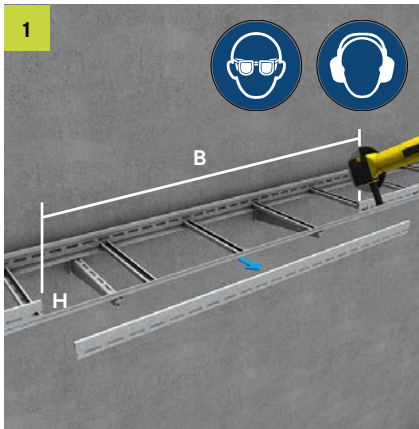

Ladder attachment branch (LGAA)

Cut out the beam of the cable ladder in a width $B = \text{width of connecting cable ladder} + 800 \text{ mm}$ to dimension H (LGAA 60 = 40.5 mm; LGAA 100 = 80.5 mm), deburr and cold galvanise.

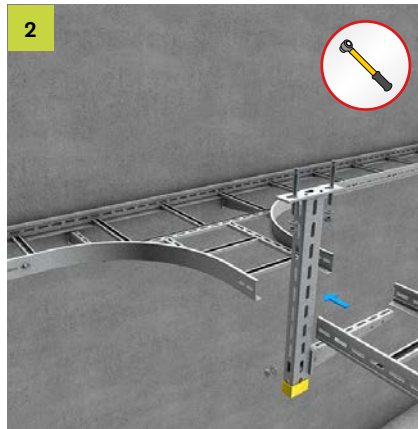

Attach the LGAA and screw it together once on each side of the beam. Insert the connecting ladder into the LGAA and screw it together like the ladder connector (LGV).

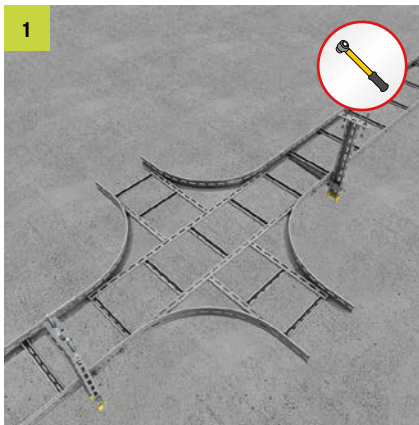

Ladder crossing (LGK)

Mount the ladder connector (LGV). Insert the LGK and screw it to the LGV.

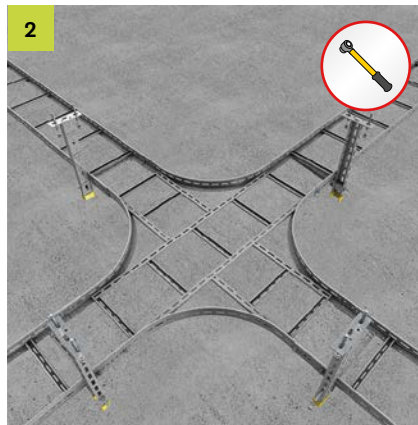

Screw the LGV to the free end of the crossing with the clamp fastening (KLS 8x16), insert the connecting ladders and screw them to the LGV.

Vertical change of direction

With standard formed parts

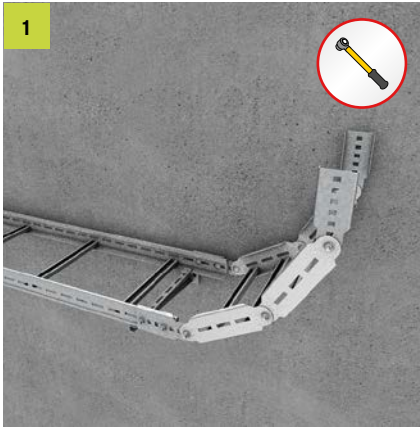

Riser or drop section with vertical bend (LGVB)

Insert LGVB into cable ladder, adjust desired change of direction and screw together like ladder connector (LGV).

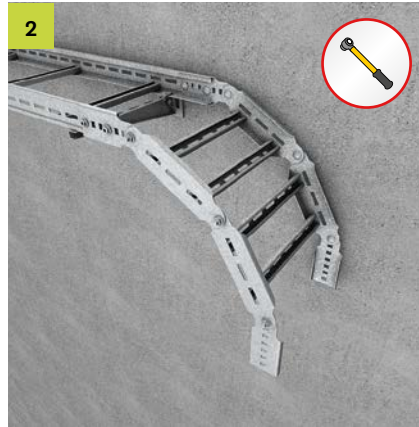

Insert the connecting cable ladder into the end of the formed part and screw it together like the LGV.

Without standard formed parts

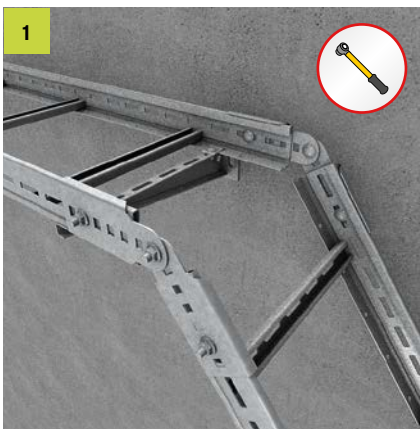

Vertical change of direction with vertical connector (LGVV)

For vertical changes of direction without formed part, push LGVV from the outside onto the beam of the cable

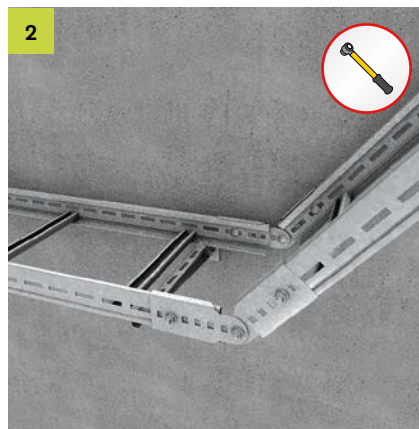

ladder and screw it with the clamp fastening (KLS 8x16) per beam. Adjust the vertical connector to the angle. Insert the connecting ladder and screw it to the LGVV.

Accessory assembly



Fastening cable ladder LGG to bracket with clamp fastening (KLU)

Screw the cable ladder with KLU twice onto the bracket.



Clamp fastening (KLUT)

Screw the KLUT for cable ladders to the steel body from below. Applies only for securing the position.



Ladder drop-out plate (LGKAB)

Place the LGKAB on the desired rung and screw it twice to the rung with a channel nut (AM16 M6) and slotted cylinder head screw (FKS 6x10).

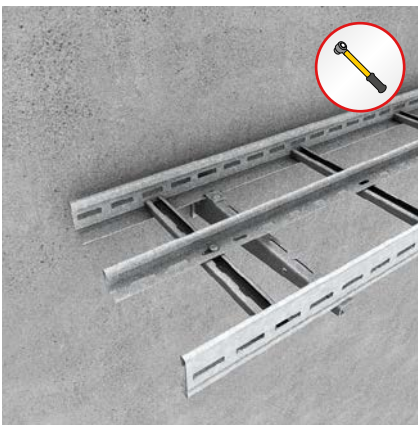

Separating strip (LGTR)

Screw LGTR three times with channel nut (AM16 M6) and slotted cylinder head screw (FKS 6x10) to rung (first rung from both partition ends as well as centrally).

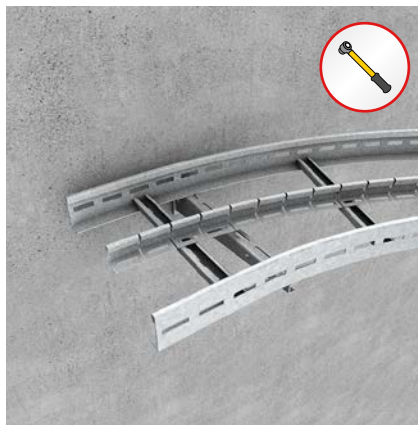

Variable separating strip (LGTRV)

Assembly analogous to LGTR. The angle can be freely selected in formed parts due to the separating web segments.

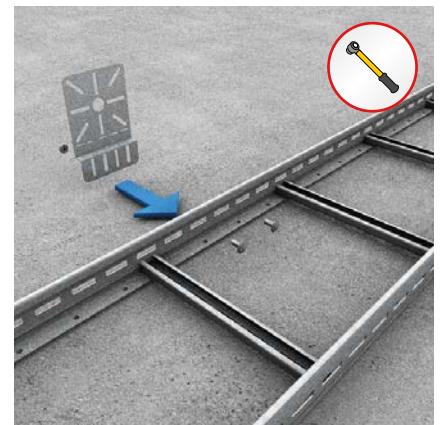

Assembly plate (MP-L)

Screw MP-L for electrical component to the side beam of the cable ladder twice.

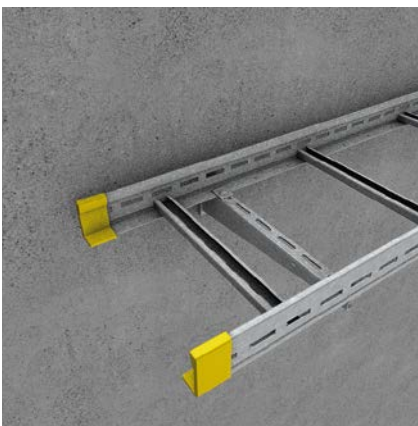

Protection cap (SL)

Depending on the situation, slide the SL onto the beam.

Cover assembly

Cover fixation in the interior

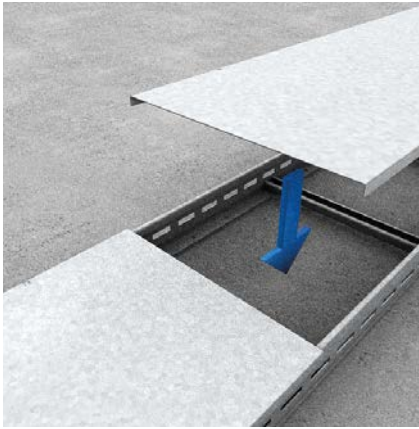

Ladder cover (LD)
Place LD on the cable ladder side beam.
Only approved for indoor use!

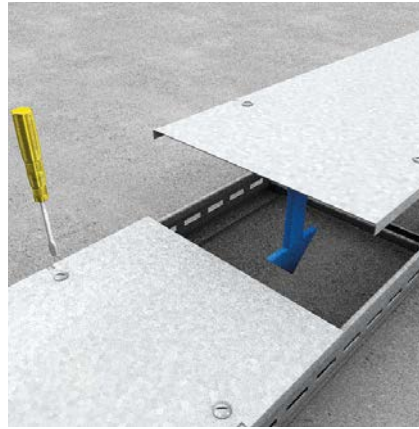

Ladder cover with turning bolt (LDR)
LDR is mounted in the same way as the ladder cover (LD). In addition, tighten the turning bolt with a screwdriver until the screw head slot points lengthwise to the side beam. Only approved for indoor use!

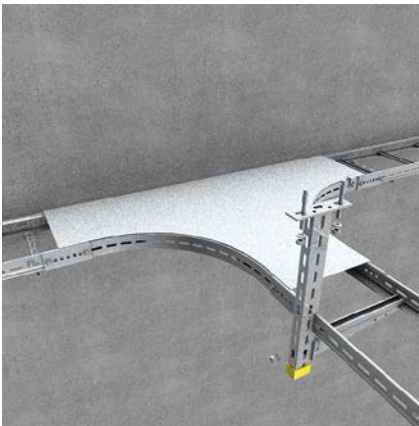

Formed part cover, e.g. ladder branch cover (LAD)
Place LAD on the ladder branch side beam (LGA). Only approved for indoor use!

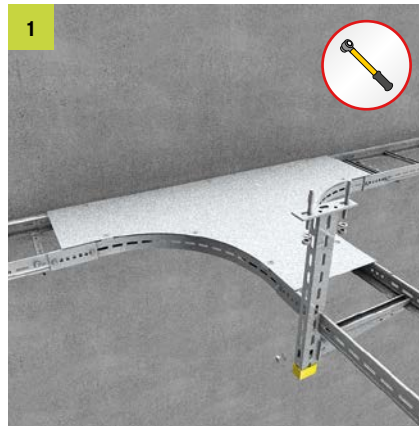

Formed part cover, e.g. ladder branch cover with turning bolt (LADR).
LADR is mounted in the same way as the ladder branch cover (LAD).

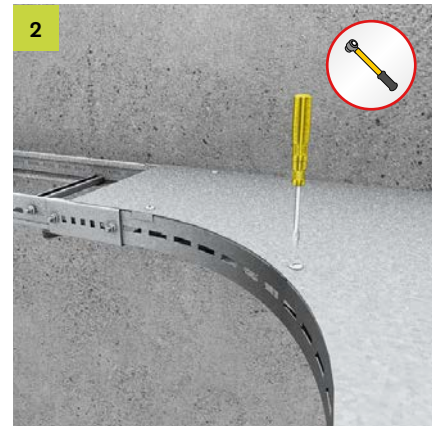

In addition, tighten the turning bolt with a screwdriver until the screw head slot points lengthwise to the side beam. Only approved for indoor use!

Cover fixation in the outdoor area

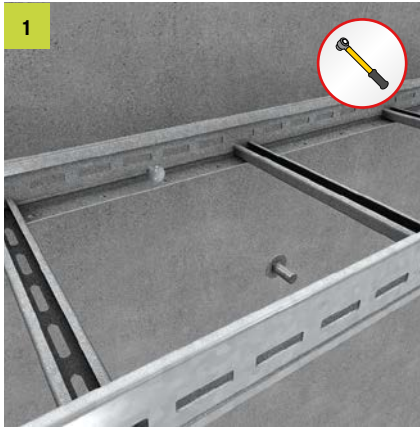

Ladder cover (LD) with storm protection angle (LD-SW).

Guide the round-head bolt (FRSV 8x16) of the LD-SW internally through the cable ladder.

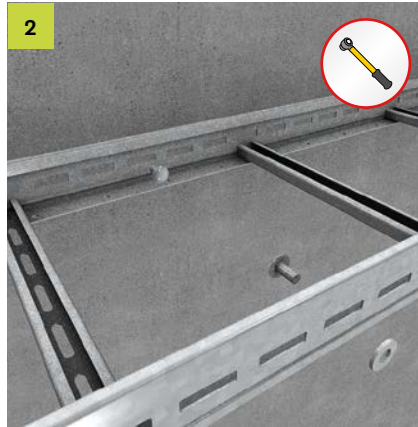

Slide the captive washer (UVS M8) onto the round-head bolt (FRSV 8x16). Position the storm protection angles 100-150 mm in front of the ends and in the middle of the cable ladder.

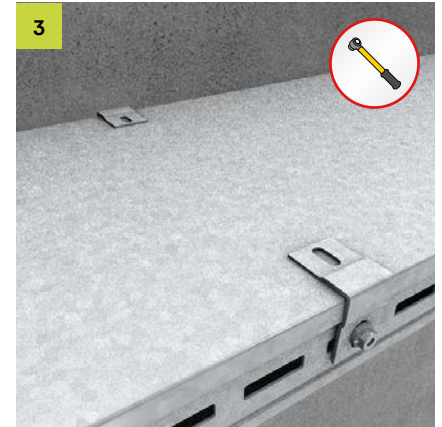

Place the LD on the cable ladder, place the LD-SW on the cover from the outside and screw it on with the hexagonal nut (SEMS 8). Suitable for outdoor use! 6 pieces/3 metres.

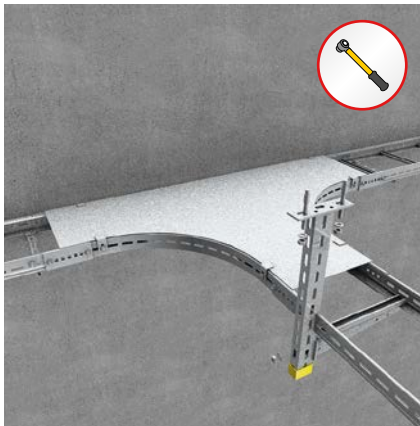

Formed part cover, e.g. ladder branch cover (LAD) with storm protection angle (LD-SW)

LD-SW for formed part covers are mounted in the same way as the ladder cover (LD). Ladder internal bend cover (LIBD) 4 pieces, ladder branch cover (LAD) 6 pieces and ladder crossing cover (LKD) 8 pieces.

All rights reserved. This document may not be reprinted or electronically reproduced without our prior written permission. The contents are subject to change without notice. Errors and omissions excepted. The publisher accepts no liability whatsoever on any legal grounds. This document supersedes all previous documentation.

© PohlCon | PC-LIT-MA-KL-EN | 08-2023 | 1. | 08-2023

PohlCon GmbH

Nobelstr. 51
12057 Berlin
Germany

T +49 30 68283-04
F +49 30 68283-383

www.pohlcon.com