

ORDER FORM

KUNEX® welded clamped construction

BK33

Rev.02 dated: 2023-03-13

| | |
|-----------|----------|
| Customer: | Project: |
| Com.: | Element: |

Clamped joint tape according to DIN 18541-2

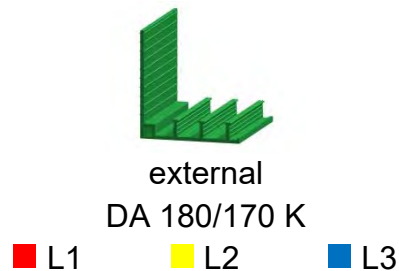
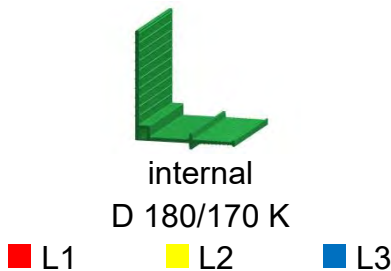

Dimensions

■ L1 = _____ mm

End specification: locked
 closed
 none

■ L2 = _____ mm

■ L3 = _____ mm

End specification: locked
 closed
 none

Number

_____ pieces

Joint tape requirements

bitumen-compatible (BV)

non bitumen-compatible (NB)

locked
(illustration exemplary)

closed
(illustration exemplary)

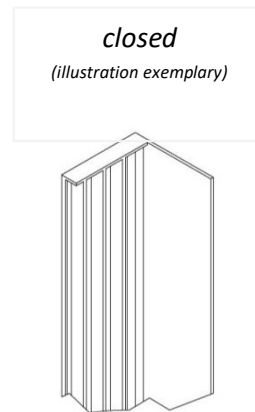
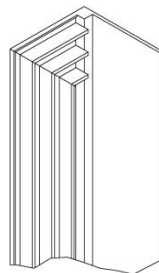

Manufacturing tolerances according to
DIN 16941 and DIN 18020 table 1:

Length ≤ 3000mm = ± 15mm

Length 3000mm – 6000mm = ± 20mm

Length > 6000mm = ± 30mm

Note:

Dimensional deviations of up to 3% are possible due to external influences such as temperature and storage conditions.

Please select joint tape design on page 2

To be completed by
H-BAU Technik (S.-no.)

ORDER FORM

KUNEX® welded construction

BK33

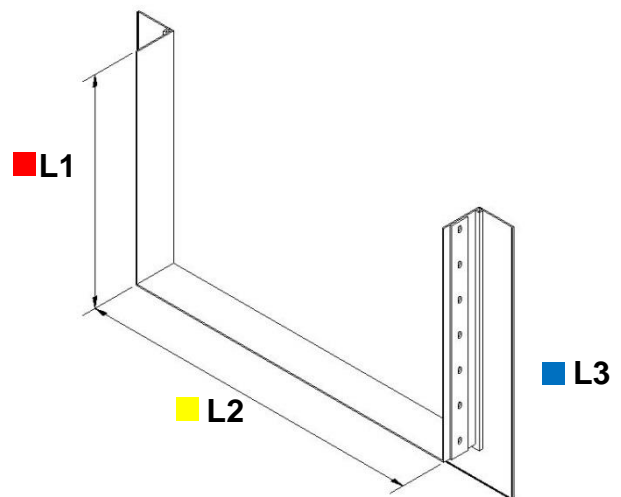
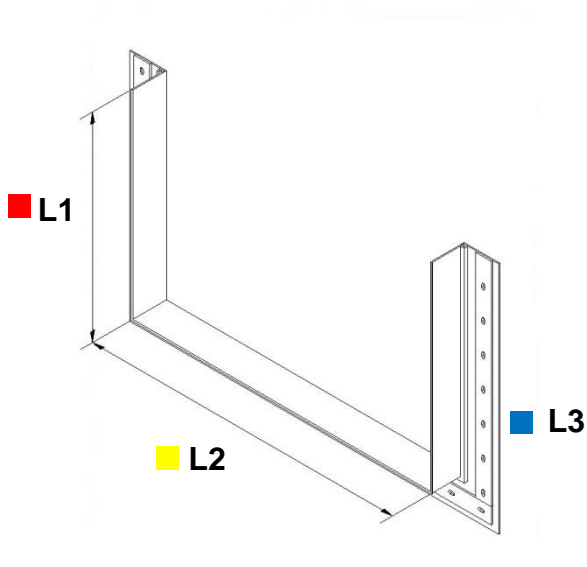
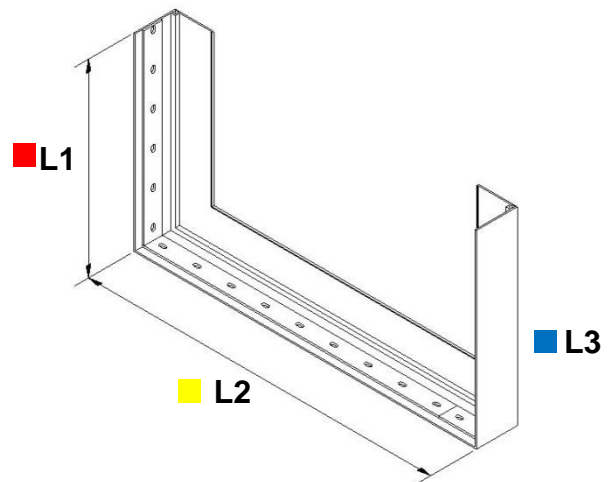
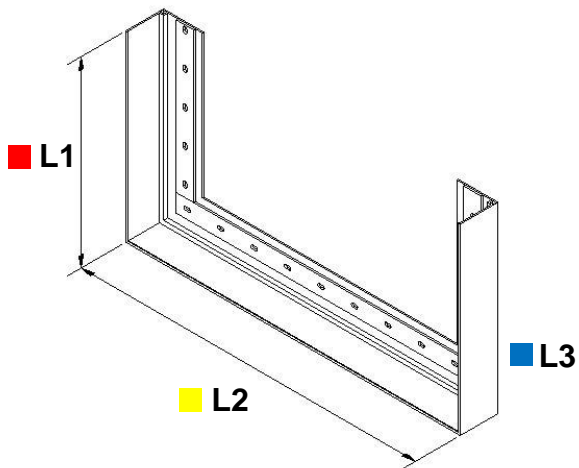

Released by: _____ date: _____