

STU 50

Steigetrasse, ungleichschenkliges U-Profil

Steigetrasse, mittelschwere Bauart, mit durchgängig gelochten Seitenholmen, zur direkten Wandbefestigung oder freistehend, eingienietete Sprossen aus Profilschiene 40x22 mm.

Der Deckel RD kann nur in Verbindung mit der Deckelerhöhung STD-A montiert werden.

Sendzimir-feuerverzinkt, nach DIN EN 10346

Artikel	H	B1	B2	L	t	P _{max}	G
STU 50-02-3S	50 mm	210 mm	172 mm	3000 mm	2 mm	2,0 kN	9,75 kg
STU 50-03-3S	50 mm	300 mm	262 mm	3000 mm	2 mm	2,0 kN	10,35 kg
STU 50-04-3S	50 mm	400 mm	362 mm	3000 mm	2 mm	2,0 kN	10,9 kg
STU 50-05-3S	50 mm	500 mm	462 mm	3000 mm	2 mm	2,0 kN	11,5 kg
STU 50-06-3S	50 mm	600 mm	562 mm	3000 mm	2 mm	2,0 kN	12,05 kg
STU 50-07-3S	50 mm	700 mm	662 mm	3000 mm	2 mm	2,0 kN	12,65 kg
STU 50-08-3S	50 mm	800 mm	762 mm	3000 mm	2 mm	2,0 kN	13,25 kg
STU 50-02S	50 mm	210 mm	172 mm	6000 mm	2 mm	2,0 kN	19,5 kg
STU 50-03S	50 mm	300 mm	262 mm	6000 mm	2 mm	2,0 kN	20,7 kg
STU 50-04S	50 mm	400 mm	362 mm	6000 mm	2 mm	2,0 kN	21,8 kg
STU 50-05S	50 mm	500 mm	462 mm	6000 mm	2 mm	2,0 kN	23,0 kg
STU 50-06S	50 mm	600 mm	562 mm	6000 mm	2 mm	2,0 kN	24,1 kg
STU 50-07S	50 mm	700 mm	662 mm	6000 mm	2 mm	2,0 kN	25,3 kg
STU 50-08S	50 mm	800 mm	762 mm	6000 mm	2 mm	2,0 kN	26,5 kg

Tauchfeuerverzinkt, nach DIN EN ISO 1461

Artikel	H	B1	B2	L	t	P _{max}	G
STU 50-02-3F	50 mm	210 mm	172 mm	3000 mm	2 mm	2,0 kN	10,50 kg
STU 50-03-3F	50 mm	300 mm	262 mm	3000 mm	2 mm	2,0 kN	11,05 kg



Artikel	H	B1	B2	L	t	P _{max}	G
STU 50-04-3F	50 mm	400 mm	362 mm	3000 mm	2 mm	2,0 kN	11,65 kg
STU 50-05-3F	50 mm	500 mm	462 mm	3000 mm	2 mm	2,0 kN	12,3 kg
STU 50-06-3F	50 mm	600 mm	562 mm	3000 mm	2 mm	2,0 kN	12,9 kg
STU 50-07-3F	50 mm	700 mm	662 mm	3000 mm	2 mm	2,0 kN	13,55 kg
STU 50-08-3F	50 mm	800 mm	762 mm	3000 mm	2 mm	2,0 kN	14,15 kg
STU 50-02F	50 mm	210 mm	172 mm	6000 mm	2 mm	2,0 kN	21,0 kg
STU 50-03F	50 mm	300 mm	262 mm	6000 mm	2 mm	2,0 kN	22,1 kg
STU 50-04F	50 mm	400 mm	362 mm	6000 mm	2 mm	2,0 kN	23,3 kg
STU 50-05F	50 mm	500 mm	462 mm	6000 mm	2 mm	2,0 kN	24,6 kg
STU 50-06F	50 mm	600 mm	562 mm	6000 mm	2 mm	2,0 kN	25,8 kg
STU 50-07F	50 mm	700 mm	662 mm	6000 mm	2 mm	2,0 kN	27,1 kg
STU 50-08F	50 mm	800 mm	762 mm	6000 mm	2 mm	2,0 kN	28,3 kg

H: Höhe
B1: Breite
B2: Breite
L: Länge
t: Materialstärke
P_{max}: max. Belastung
G: Gewicht

DETAILS / ANWENDUNGEN

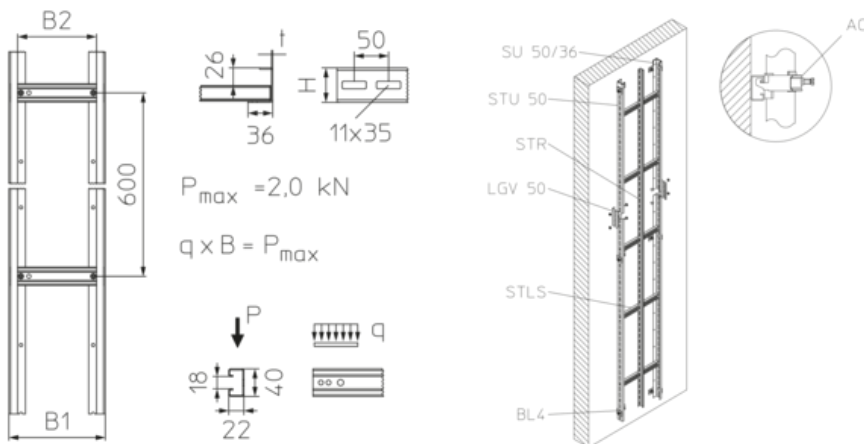

OPTIONALES ZUBEHÖR

STLS, AC, STR 50, STR 110, LGV 50, STD-A, ST-RD, BGUQ 50, BL 4, LH, SU 50/36

