

SRHD

Schutzrohrhalter, drehbar

Tauchfeuerverzinkt, nach DIN EN ISO 1461

Artikel	H	B	L	D	t	G
SRHD 30F	62 mm	1,5 mm	80 mm	30 mm	1,50 mm	0,7 kg
SRHD 60F	102 mm	1,5 mm	115 mm	60 mm	2,00 mm	1,2 kg

H: Höhe
B: Breite
L: Länge
D: Durchmesser
t: Materialstärke
G: Gewicht

DETAILS / ANWENDUNGEN

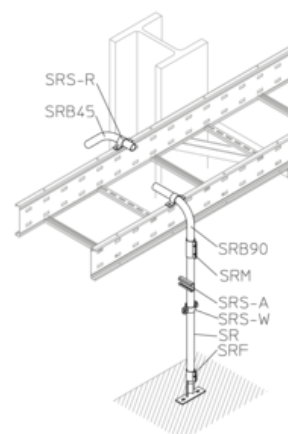
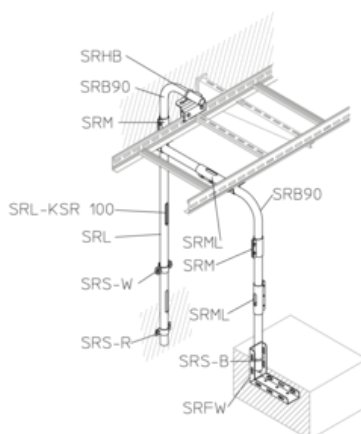
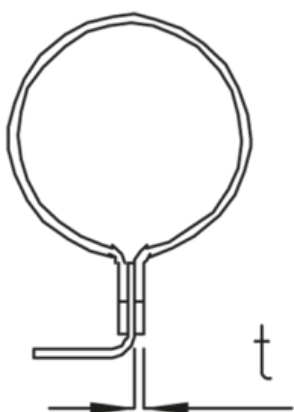

Seite 1



