

## SLS

Schiffsleiter, Fall-/Steigstück, Höhe = 30 mm

Schiffsleiterbogen 90 Grad, zur vertikalen Richtungsänderung

### Unverzinkt

Artikel	H	B	R	G
SLS 075B	30 mm	75 mm	150 mm	0,9 kg
SLS 100B	30 mm	100 mm	150 mm	1 kg
SLS 150B	30 mm	150 mm	150 mm	1 kg
SLS 200B	30 mm	200 mm	150 mm	1,3 kg
SLS 250B	30 mm	250 mm	150 mm	1,5 kg
SLS 300B	30 mm	300 mm	150 mm	1,7 kg
SLS 400B	30 mm	400 mm	150 mm	2,8 kg
SLS 500B	30 mm	500 mm	150 mm	3,3 kg

### Tauchfeuerverzinkt, nach DIN EN ISO 1461

Artikel	H	B	R	G
SLS 075F	30 mm	75 mm	150 mm	0,9 kg
SLS 100F	30 mm	100 mm	150 mm	1 kg
SLS 150F	30 mm	150 mm	150 mm	1 kg
SLS 200F	30 mm	200 mm	150 mm	1,3 kg
SLS 250F	30 mm	250 mm	150 mm	1,5 kg
SLS 300F	30 mm	300 mm	150 mm	1,7 kg
SLS 400F	30 mm	400 mm	150 mm	2,8 kg
SLS 500F	30 mm	500 mm	150 mm	3,3 kg



schweißgrundiert

Artikel	H	B	R	G
SLS 075M	30 mm	75 mm	150 mm	0,9 kg
SLS 100M	30 mm	100 mm	150 mm	1 kg
SLS 150M	30 mm	150 mm	150 mm	1 kg
SLS 200M	30 mm	200 mm	150 mm	1,3 kg
SLS 250M	30 mm	250 mm	150 mm	1,5 kg
SLS 300M	30 mm	300 mm	150 mm	1,7 kg
SLS 400M	30 mm	400 mm	150 mm	2,8 kg
SLS 500M	30 mm	500 mm	150 mm	3,3 kg

**H:** Höhe  
**B:** Breite  
**R:** Radius  
**G:** Gewicht

## DETAILS / ANWENDUNGEN

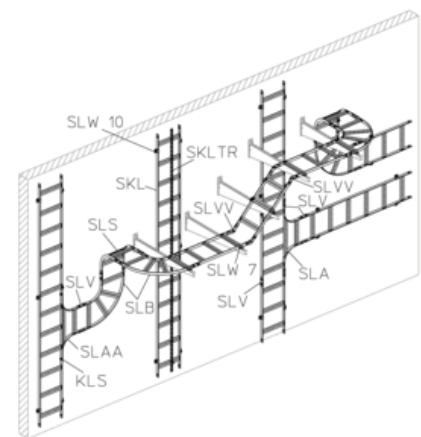
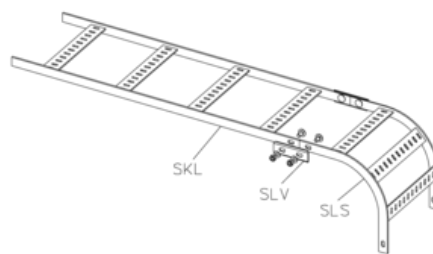
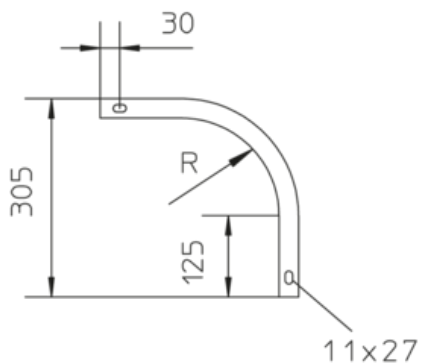

## OPTIONALES ZUBEHÖR

SLW, SLV, SLVV

