

## SLA

Schiffsleiterabzweig, Höhe = 30 mm

Schiffsleiterabzweig, Formteil als T-Stück

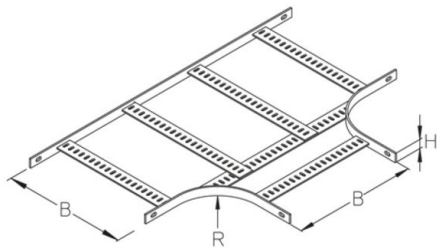

### Unverzinkt

Artikel	H	B	R	G
SLA 075B	30 mm	75 mm	100 mm	2,5 kg
SLA 100B	30 mm	100 mm	100 mm	2,7 kg
SLA 150B	30 mm	150 mm	100 mm	3,2 kg
SLA 200B	30 mm	200 mm	100 mm	3,6 kg
SLA 250B	30 mm	250 mm	100 mm	4,1 kg
SLA 300B	30 mm	300 mm	150 mm	5,4 kg
SLA 400B	30 mm	400 mm	150 mm	6,5 kg
SLA 500B	30 mm	500 mm	200 mm	8,8 kg

### Tauchfeuerverzinkt, nach DIN EN ISO 1461

Artikel	H	B	R	G
SLA 075F	30 mm	75 mm	100 mm	2,5 kg
SLA 100F	30 mm	100 mm	100 mm	2,7 kg
SLA 150F	30 mm	150 mm	100 mm	3,2 kg
SLA 200F	30 mm	200 mm	100 mm	3,6 kg
SLA 250F	30 mm	250 mm	100 mm	4,1 kg
SLA 300F	30 mm	300 mm	150 mm	5,4 kg
SLA 400F	30 mm	400 mm	150 mm	6,5 kg
SLA 500F	30 mm	500 mm	200 mm	8,8 kg



schweißgrundiert

Artikel	H	B	R	G
SLA 075M	30 mm	75 mm	100 mm	2,5 kg
SLA 100M	30 mm	100 mm	100 mm	2,7 kg
SLA 150M	30 mm	150 mm	100 mm	3,2 kg
SLA 200M	30 mm	200 mm	100 mm	3,6 kg
SLA 250M	30 mm	250 mm	100 mm	4,1 kg
SLA 300M	30 mm	300 mm	150 mm	5,4 kg
SLA 400M	30 mm	400 mm	150 mm	6,5 kg
SLA 500M	30 mm	500 mm	200 mm	8,8 kg

**H:** Höhe  
**B:** Breite  
**R:** Radius  
**G:** Gewicht

## DETAILS / ANWENDUNGEN

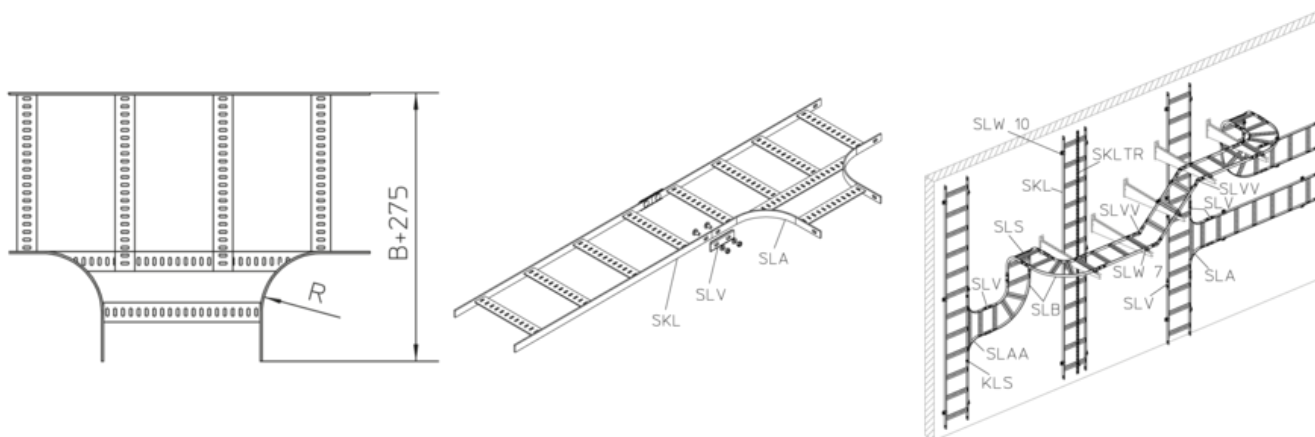

## OPTIONALES ZUBEHÖR

SLW, SLV, SLVV

