

SKS A

Spannklaue, schwer, A/KHA 21/41/42/82

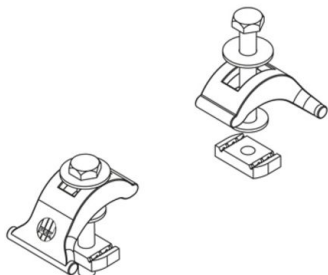

Tauchfeuerverzinkt, nach DIN EN ISO 1461

Artikel	k	P_{max}	M	G
SKS AF	10 - 30 mm	20 kN	50 Nm	0,56 kg/Satz
inklusive:				
2x SES 10X75F		Sechskantschraube, DIN 933		
2x US 10X30F		Unterlegscheibe, DIN EN ISO 7093		
2x AM22 M10F		Ankermutter, A 41, KHA 41, KHAL 41		
2x UVS M10X24		Unverlierbarkeitsscheibe		

Edelstahl, Werkstoff Nr. 1.4571/1.4404 (V4A)

Artikel	k	P_{max}	M	G
SKS AE4	10 - 30 mm	20 kN	50 Nm	0,59 kg/Satz
inklusive:				
2x SES 10X75E4		Sechskantschraube, DIN 933		
2x US 10X30E4		Unterlegscheibe, DIN EN ISO 7093		
2x UVS M10X24		Unverlierbarkeitsscheibe		
2x AM22 M10E4		Ankermutter, A 41, KHA 41, KHAL 41		

k: Klemmbereich
 P_{max} : max. Belastung
M: Drehmoment
G: Gewicht



DETAILS / ANWENDUNGEN

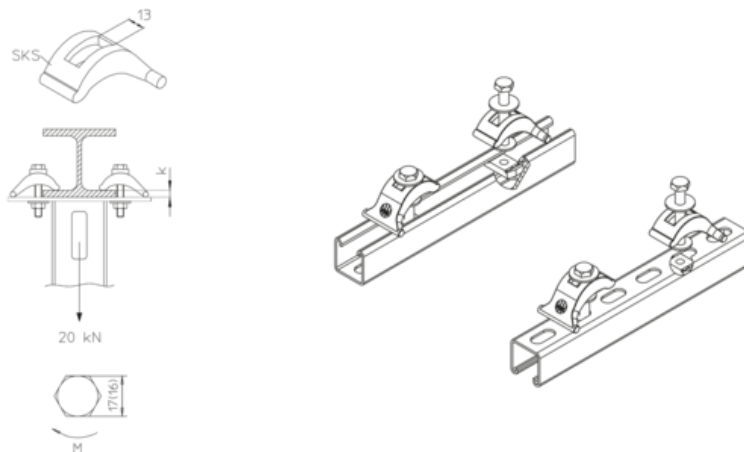

OPTIONALES ZUBEHÖR

A 41, KHA 41

