

SKL A

Trägerklemmenset

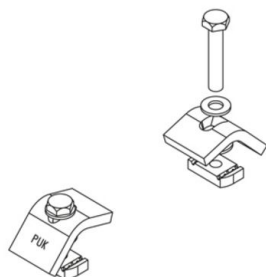

Tauchfeuerverzinkt, nach DIN EN ISO 1461

Artikel	k	P_{\max}	M	G
SKL AF	5 - 25 mm	10 kN	35 Nm	0,49 kg/Satz
inklusive:				
2x SES 10X55F		Sechskantschraube, DIN 933		
2x US 10X21F		Unterlegscheibe, DIN EN ISO 7089		
2x AM22 M10F		Ankermutter, A 41, KHA 41, KHAL 41		
2x UVS M10X24		Unverlierbarkeitsscheibe		

Edelstahl, Werkstoff Nr. 1.4571/1.4404 (V4A)

Artikel	k	P_{\max}	M	G
SKL AE4	5 - 25 mm	10 kN	35 Nm	0,49 kg/Satz
inklusive:				
2x SES 10X55E4		Sechskantschraube, DIN 933		
2x US 10X21E4		Unterlegscheibe, DIN EN ISO 7089		
2x AM22 M10E4		Ankermutter, A 41, KHA 41, KHAL 41		
2x UVS M10X24		Unverlierbarkeitsscheibe		

k: Klemmbereich
 P_{\max} : max. Belastung
M: Drehmoment
G: Gewicht



DETAILS / ANWENDUNGEN

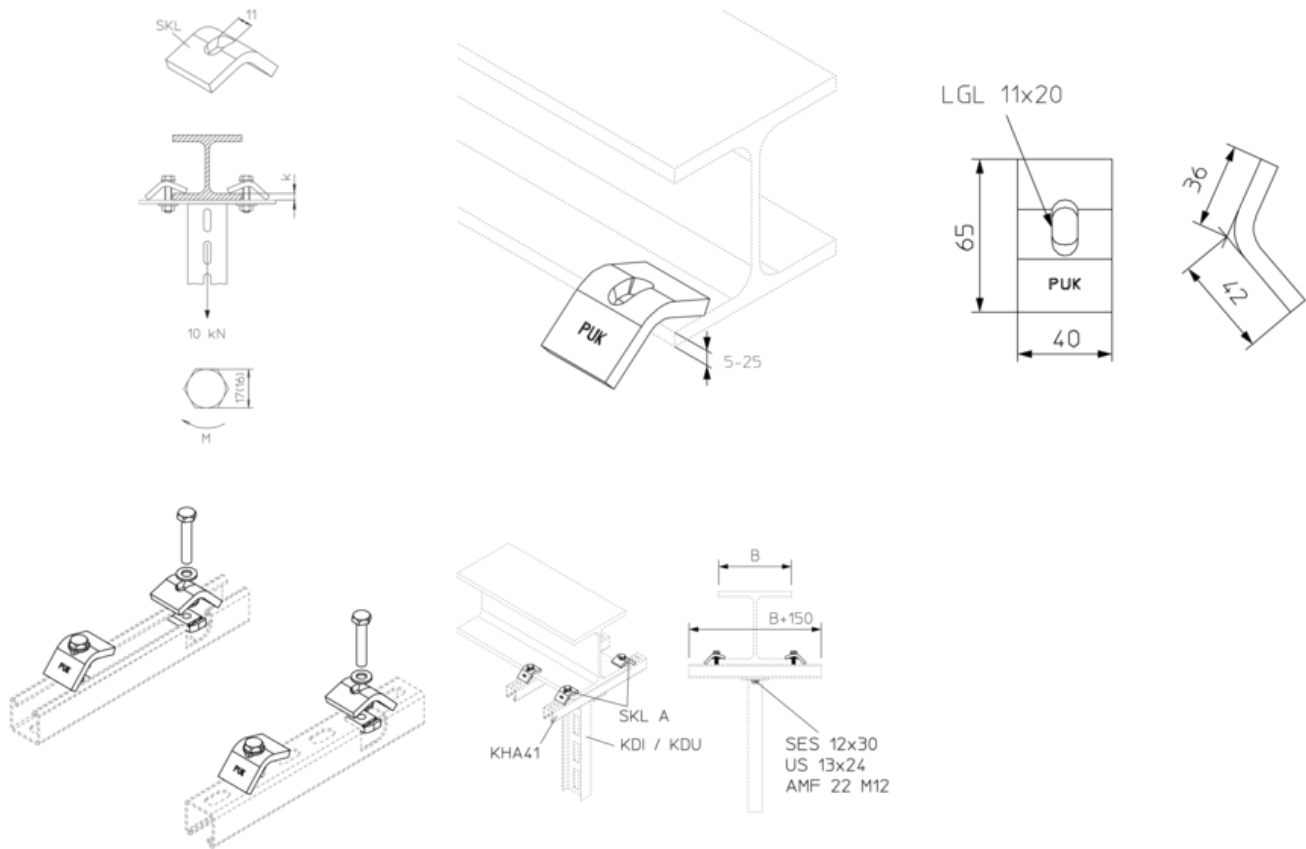

OPTIONALES ZUBEHÖR

A 41, KHA 41, KHAL 41

