

SK
Spannklaue

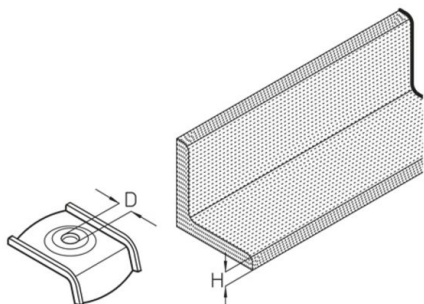

Tauchfeuerverzinkt, nach DIN EN ISO 1461

Artikel	H	D	G
SK 4 M8	4 mm	M 8 mm	3,5 kg/100
SK 6 M8	6 mm	M 8 mm	3,7 kg/100
SK 8 M8	8 mm	M 8 mm	4 kg/100
SK 10 M8	10 mm	M 8 mm	4,1 kg/100
SK 12 M8	12 mm	M 8 mm	4,4 kg/100

H: Höhe
D: Durchmesser
G: Gewicht

DETAILS / ANWENDUNGEN



