

SC
Spannschloss

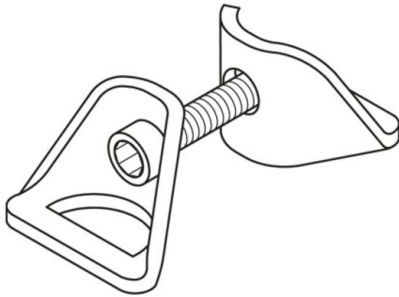

Tauchfeuerverzinkt, nach DIN EN ISO 1461

Artikel	G
SC	6,5 kg/100
inklusive: 1x IK 8X40E	Innensechskantschraube, DIN 912

G: Gewicht

DETAILS / ANWENDUNGEN

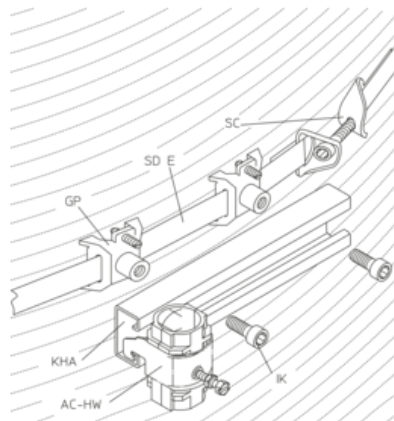
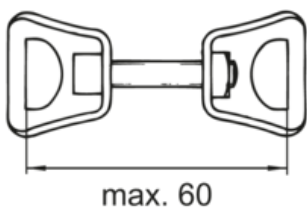

OPTIONALES ZUBEHÖR

GP, SD E

