

LW Langwanne

Langwanne zur verbesserten Kabelaufgabe. Zugelassen nach DIN 4102-12.

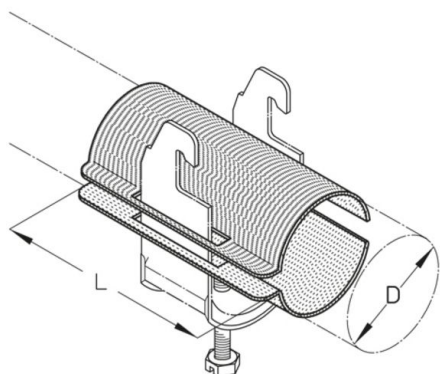

Sendzimir-feuerverzinkt, nach DIN EN 10346

Artikel	L	D	G
LW 12	70 mm	9-12 mm	0,92 kg/100
LW 16	70 mm	13-16 mm	0,97 kg/100
LW 20	70 mm	17-20 mm	1,24 kg/100
LW 24	70 mm	21-24 mm	1,52 kg/100
LW 28	70 mm	25-28 mm	1,79 kg/100
LW 32	70 mm	29-32 mm	2,18 kg/100
LW 36	70 mm	33-36 mm	2,34 kg/100
LW 40	70 mm	37-40 mm	2,62 kg/100
LW 44	70 mm	41-44 mm	3,08 kg/100
LW 48	70 mm	45-48 mm	3,39 kg/100
LW 52	70 mm	49-52 mm	3,64 kg/100
LW 56	70 mm	53-56 mm	3,98 kg/100
LW 60	70 mm	57-60 mm	4,26 kg/100
LW 64	70 mm	61-64 mm	4,53 kg/100
LW 70	70 mm	65-70 mm	5,95 kg/100
LW 76	70 mm	71-76 mm	11,50 kg/100
LW 82	100 mm	77-82 mm	12,30 kg/100
LW 88	100 mm	83-88 mm	13,00 kg/100
LW 94	100 mm	89-94 mm	13,80 kg/100
LW 100	100 mm	95-100 mm	15,00 kg/100
LW 110	100 mm	101-110 mm	16,50 kg/100

Seite 1



Artikel	L	D	G
LW 120	100 mm	111-120 mm	17,80 kg/100

Edelstahl, Werkstoff Nr. 1.4301 (V2A)

Artikel	L	D	G
LW 12E	70 mm	9-12 mm	0,92 kg/100
LW 16E	70 mm	13-16 mm	0,98 kg/100
LW 20E	70 mm	17-20 mm	1,25 kg/100
LW 24E	70 mm	21-24 mm	1,53 kg/100
LW 28E	70 mm	25-28 mm	1,81 kg/100
LW 32E	70 mm	29-32 mm	2,19 kg/100
LW 36E	70 mm	33-36 mm	2,36 kg/100
LW 40E	70 mm	37-40 mm	2,63 kg/100
LW 44E	70 mm	41-44 mm	3,10 kg/100
LW 48E	70 mm	45-48 mm	3,41 kg/100
LW 52E	70 mm	49-52 mm	3,66 kg/100
LW 56E	70 mm	53-56 mm	4,02 kg/100

L: Länge
D: Durchmesser
G: Gewicht

DETAILS / ANWENDUNGEN

