

**KPH**  
Halteklau

Tauchfeuerverzinkt, nach DIN EN ISO 1461

Artikel	B	L	D	G
KPH 8F	46 mm	40 mm	M8 mm	0,08 kg
KPH-PG 9	46 mm	40 mm	PG 9 mm	0,06 kg

**B:** Breite  
**L:** Länge  
**D:** Durchmesser  
**G:** Gewicht

DETAILS / ANWENDUNGEN

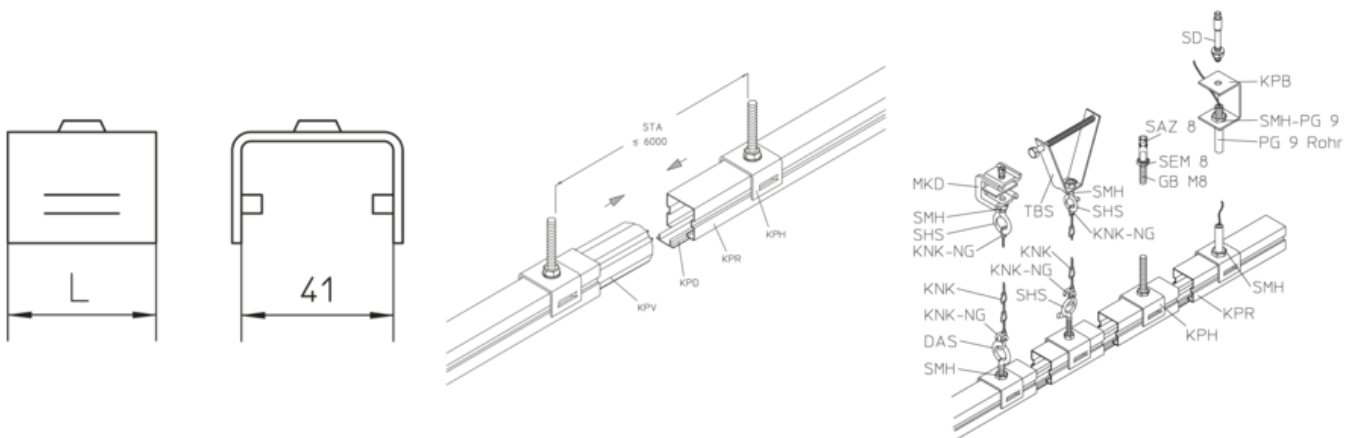

## OPTIONALES ZUBEHÖR

DAS, SHS

