

## HF-EM 8 1-4

HF-Kabelschelle zur Wandbefestigung

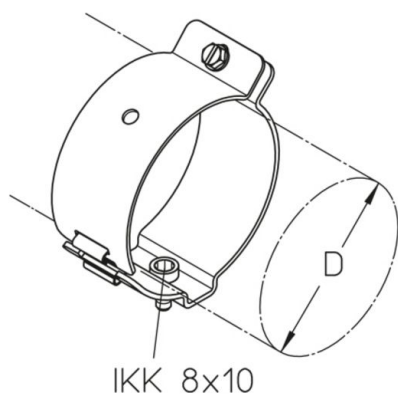

### Verzinkt

Artikel	D	G
HF-EM 8 1	37 (E 130-190) mm	13,4 kg/100
HF-EM 8 2	50 (E 78-105) mm	14,8 kg/100
HF-EM 8 3	62 (E 60-70) mm	16,9 kg/100
HF-EM 8 4	100 (E 38-46) mm	24 kg/100

**D:** Durchmesser  
**G:** Gewicht

## OPTIONALES ZUBEHÖR

HF-EE

