

## FKS

Zylinderschrauben mit Schlitz, DIN EN ISO 1580

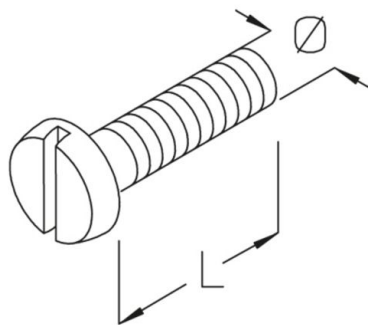

galvanisch verzinkt gemäß DIN EN ISO 19598 / DIN EN ISO 2081

Artikel	L	D	Ø	G
FKS 6X10	10 mm	12 mm	6 mm	0,4 kg/100
FKS 6X20	20 mm	12 mm	6 mm	0,6 kg/100
FKS 6X25	25 mm	12 mm	6 mm	0,7 kg/100
FKS 8X20	20 mm	16 mm	8 mm	1,3 kg/100

Edelstahl, Werkstoff Nr. 1.4301 (V2A)

Artikel	L	D	Ø	G
FKS 6X10E	10 mm	12 mm	6 mm	0,4 kg/100
FKS 6X16E	16 mm	12 mm	6 mm	0,4 kg/100
FKS 6X20E	20 mm	12 mm	6 mm	0,6 kg/100
FKS 6X25E	25 mm	12 mm	6 mm	0,7 kg/100

Edelstahl, Werkstoff Nr. 1.4571/1.4404 (V4A)

Artikel	L	D	Ø	G
FKS 6X12E4	12 mm	12 mm	6 mm	0,4 kg/100
FKS 6X16E4	16 mm	12 mm	6 mm	0,4 kg/100
FKS 8X16E4	16 mm	16 mm	8 mm	1,1 kg/100

Seite.1



**L:** Länge  
**D:** Durchmesser  
**Ø:** Durchmesser  
**G:** Gewicht

## DETAILS / ANWENDUNGEN

