

STU 60

Steigetrasse, gleichschenkliges U-Profil

Die Steigetrasse STU 60 bestehen aus gelochten Seitenholmen im U-Profil und Sprossen aus Profilschienen 40x22 mm. Sie sind für eine maximale Belastung bis 2,00 kN ausgelegt, weisen Breiten von 200 bis 1200 mm auf und sind in den Standardlängen 3000 und 6000 mm erhältlich. Verschiedene Materialien und Oberflächen sorgen dafür, dass die Korrosionsanforderungen unterschiedlichster Anwendungsgebiete erfüllt werden.

Stahl, stück-/tauchfeuerverzinkt

Artikel	H	B	L	P _{max}	Gewicht
STU 60-02-3F	60 mm	200 mm	3000 mm	2,00 kN	22,980 kg
inklusive: 2 × KHU 60-30F, 5 × STUS 60-02F					
STU 60-03-3F	60 mm	300 mm	3000 mm	2,00 kN	23,730 kg
inklusive: 2 × KHU 60-30F, 5 × STUS 60-03F					
STU 60-04-3F	60 mm	400 mm	3000 mm	2,00 kN	24,530 kg
inklusive: 2 × KHU 60-30F, 5 × STUS 60-04F					
STU 60-05-3F	60 mm	500 mm	3000 mm	2,00 kN	25,280 kg
inklusive: 2 × KHU 60-30F, 5 × STUS 60-05F					
STU 60-06-3F	60 mm	600 mm	3000 mm	2,00 kN	26,080 kg
inklusive: 2 × KHU 60-30F, 5 × STUS 60-06F					
STU 60-07-3F	60 mm	700 mm	3000 mm	2,00 kN	26,830 kg
inklusive: 2 × KHU 60-30F, 5 × STUS 60-07F					
STU 60-08-3F	60 mm	800 mm	3000 mm	2,00 kN	27,630 kg
inklusive: 5 × STUS 60-08F, 2 × KHU 60-30F					

Seite 1



PRODUKTINFORMATION

Artikel	H	B	L	P _{max}	Gewicht
STU 60-09-3F	60 mm	900 mm	3000 mm	2,00 kN	28,380 kg
inklusive: 2 × KHU 60-30F, 5 × STUS 60-09F					
STU 60-10-3F	60 mm	1000 mm	3000 mm	2,00 kN	29,130 kg
inklusive: 2 × KHU 60-30F, 5 × STUS 60-10F					
STU 60-11-3F	60 mm	1100 mm	3000 mm	2,00 kN	29,880 kg
inklusive: 2 × KHU 60-30F, 5 × STUS 60-11F					
STU 60-12-3F	60 mm	1200 mm	3000 mm	2,00 kN	30,680 kg
inklusive: 2 × KHU 60-30F, 5 × STUS 60-12F					
STU 60-02F	60 mm	200 mm	6000 mm	2,00 kN	46,040 kg
inklusive: 2 × KHU 60-60F, 10 × STUS 60-02F					
STU 60-03F	60 mm	300 mm	6000 mm	2,00 kN	47,540 kg
inklusive: 10 × STUS 60-03F, 2 × KHU 60-60F					
STU 60-04F	60 mm	400 mm	6000 mm	2,00 kN	49,140 kg
inklusive: 2 × KHU 60-60F, 5 × STUS 60-04F					
STU 60-05F	60 mm	500 mm	6000 mm	2,00 kN	50,640 kg
inklusive: 2 × KHU 60-60F, 10 × STUS 60-05F					
STU 60-06F	60 mm	600 mm	6000 mm	2,00 kN	52,240 kg
inklusive: 2 × KHU 60-60F, 10 × STUS 60-06F					
STU 60-07F	60 mm	700 mm	6000 mm	2,00 kN	53,740 kg
inklusive: 2 × KHU 60-60F, 10 × STUS 60-07F					
STU 60-08F	60 mm	800 mm	6000 mm	2,00 kN	55,340 kg
inklusive: 2 × KHU 60-60F, 10 × STUS 60-08F					
STU 60-09F	60 mm	900 mm	6000 mm	2,00 kN	56,840 kg

Seite 2



PRODUKTINFORMATION

Artikel	H	B	L	P _{max}	Gewicht
inklusive: 2 × KHU 60-60F, 10 × STUS 60-09F					
STU 60-10F	60 mm	1000 mm	6000 mm	2,00 kN	58,340 kg
inklusive: 2 × KHU 60-60F, 10 × STUS 60-10F					
STU 60-11F	60 mm	1100 mm	6000 mm	2,00 kN	59,840 kg
inklusive: 10 × STUS 60-11F, 2 × KHU 60-60F					
STU 60-12F	60 mm	1200 mm	6000 mm	2,00 kN	61,440 kg
inklusive: 2 × KHU 60-60F, 10 × STUS 60-12F					

Edelstahl, Werkstoff Nr. 1.4301 (V2A)

Artikel	H	B	L	P _{max}	Gewicht
STU 60-02-3E	60 mm	200 mm	3000 mm	2,00 kN	21,620 kg
inklusive: 2 × KHU 60-30E, 5 × STUS 60-02E					
STU 60-03-3E	60 mm	300 mm	3000 mm	2,00 kN	22,370 kg
inklusive: 2 × KHU 60-30E, 5 × STUS 60-03E					
STU 60-04-3E	60 mm	400 mm	3000 mm	2,00 kN	23,120 kg
inklusive: 2 × KHU 60-30E, 5 × STUS 60-04E					
STU 60-05-3E	60 mm	500 mm	3000 mm	2,00 kN	23,870 kg
inklusive: 2 × KHU 60-30E, 10 × STUS 60-05E					
STU 60-06-3E	60 mm	600 mm	3000 mm	2,00 kN	24,570 kg
inklusive: 2 × KHU 60-30E, 5 × STUS 60-06E					
STU 60-07-3E	60 mm	700 mm	3000 mm	2,00 kN	25,320 kg
inklusive: 2 × KHU 60-30E, 5 × STUS 60-07E					

Seite 3



PRODUKTINFORMATION

Artikel	H	B	L	P _{max}	Gewicht
STU 60-08-3E	60 mm	800 mm	3000 mm	2,00 kN	26,070 kg
inklusive: 5 × STUS 60-08E, 2 × KHU 60-30E					
STU 60-09-3E	60 mm	900 mm	3000 mm	2,00 kN	26,770 kg
inklusive: 2 × KHU 60-30E, 5 × STUS 60-09E					
STU 60-10-3E	60 mm	1000 mm	3000 mm	2,00 kN	27,520 kg
inklusive: 2 × KHU 60-30E, 5 × STUS 60-10E					
STU 60-11-3E	60 mm	1100 mm	3000 mm	2,00 kN	28,270 kg
inklusive: 2 × KHU 60-30E, 5 × STUS 60-11E					
STU 60-12-3E	60 mm	1200 mm	3000 mm	2,00 kN	28,970 kg
inklusive: 2 × KHU 60-30E, 5 × STUS 60-12E					
STU 60-02E	60 mm	200 mm	6000 mm	2,00 kN	43,500 kg
inklusive: 2 × KHU 60-60E, 10 × STUS 60-02E					
STU 60-03E	60 mm	300 mm	6000 mm	2,00 kN	45,000 kg
inklusive: 2 × KHU 60-60E, 10 × STUS 60-03E					
STU 60-04E	60 mm	400 mm	6000 mm	2,00 kN	46,500 kg
inklusive: 2 × KHU 60-60E, 10 × STUS 60-04E					
STU 60-05E	60 mm	500 mm	6000 mm	2,00 kN	48,000 kg
inklusive: 10 × STUS 60-05E, 2 × KHU 60-60E					
STU 60-06E	60 mm	600 mm	6000 mm	2,00 kN	49,400 kg
inklusive: 2 × KHU 60-60E, 10 × STUS 60-06E					
STU 60-07E	60 mm	700 mm	6000 mm	2,00 kN	50,900 kg
inklusive: 2 × KHU 60-60E, 10 × STUS 60-07E					
STU 60-08E	60 mm	800 mm	6000 mm	2,00 kN	52,400 kg

Seite 4



PRODUKTINFORMATION

Artikel	H	B	L	P_{max}	Gewicht
inklusive: 2 × KHU 60-60E, 10 × STUS 60-08E					
STU 60-09E	60 mm	900 mm	6000 mm	2,00 kN	53,800 kg
inklusive: 2 × KHU 60-60E, 10 × STUS 60-09E					
STU 60-10E	60 mm	1000 mm	6000 mm	2,00 kN	55,300 kg
inklusive: 2 × KHU 60-60E, 5 × STUS 60-10E					
STU 60-11E	60 mm	1100 mm	6000 mm	2,00 kN	56,800 kg
inklusive: 2 × KHU 60-60E, 10 × STUS 60-11E					
STU 60-12E	60 mm	1200 mm	6000 mm	2,00 kN	58,200 kg
inklusive: 2 × KHU 60-60E, 10 × STUS 60-12E					

H: Höhe
B: Breite
L: Länge
 P_{max} : max. Belastung
Gewicht: Gewicht je Lagermengeneinheit

DETAIL- UND ANWENDUNGSBILDER

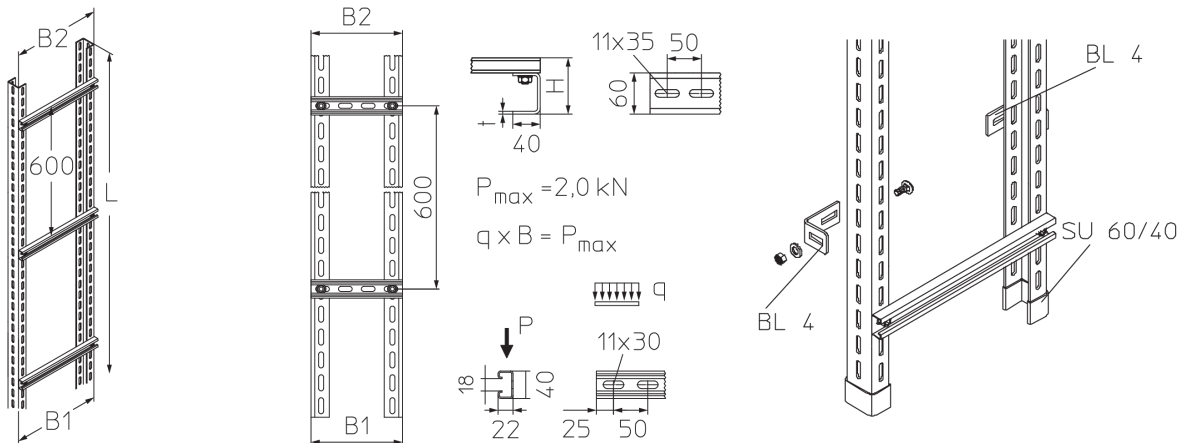

Seite 5



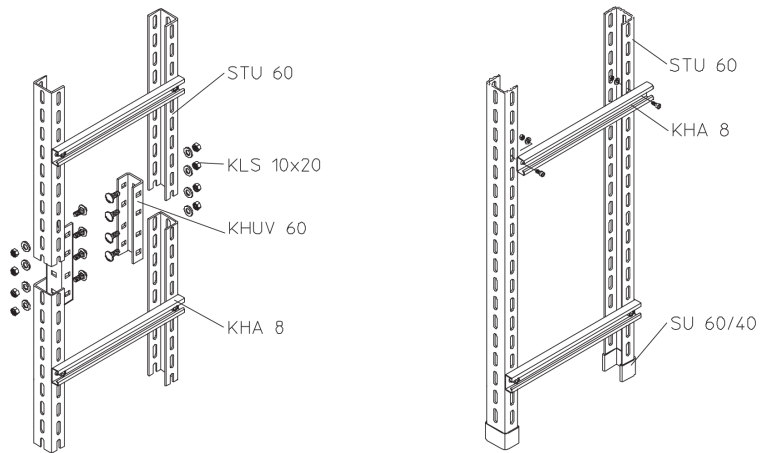

OPTIONALES ZUBEHÖR

STUS 60, AC, KHUV 60, STR 50, STR 110, STD-A, RD, BGU 60, BL 4, SU 60, KZF, KZS

