

RTR 60

Kabelrinnen-Trennsteg, Höhe = 50 mm Fluchtweginstallation

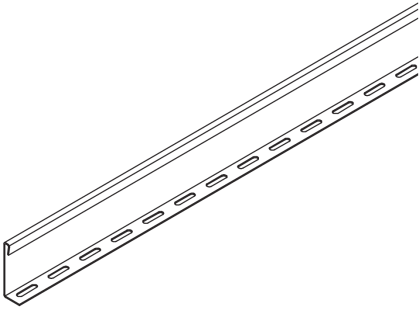

Stahl, band-/sendzimirverzinkt

Artikel	H	L	G
RTR 60S	50 mm	3000 mm	1,528 kg
inklusive:			
3 x KLR			

H: Höhe
L: Länge
G: Gewicht je Lagermengeneinheit

DETAIL- UND ANWENDUNGSBILDER

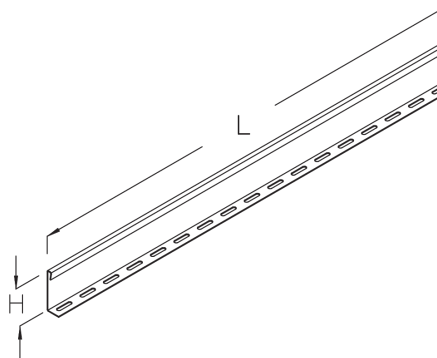
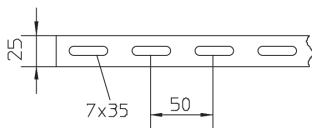



PohlCon GmbH
Nobelstraße 51 | 12057 Berlin
Telefon: +49 30 68283-04 | Fax: +49 30 68283-383 | contact@pohlcon.com

