

LGV-BS 60

Kabelleiter-Verbinder, Höhe = 60 mm, Funktionserhalt

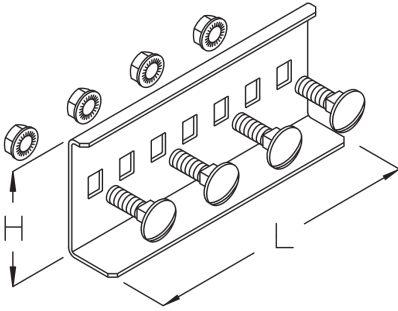

Stahl, band-/sendzimirverzinkt

Artikel	H	L	Gewicht
LGV-BS 60S	60 mm	150 mm	0,272 kg
inklusive:			
4 × KLS 8X16			

Stahl, stück-/tauchfeuerverzinkt

Artikel	H	L	Gewicht
LGV-BS 60F	60 mm	150 mm	0,285 kg
inklusive:			
4 × KLS 8X16E			

H: Höhe

L: Länge

Gewicht: Gewicht je Lagermengeneinheit

DETAIL- UND ANWENDUNGSBILDER



