

KAD-BS

Konsoladapter Fluchtweginstallation

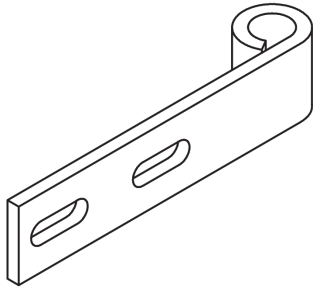

Stahl, band-/sendzimirverzinkt

Artikel	Ø	Gewicht
KAD-BS S	13 mm	0,210 kg
inklusive: 2 x IK 8X20, 2 x SEMS 8		

Ø: Innendurchmesser

Gewicht: Gewicht je Lagermengeneinheit

DETAIL- UND ANWENDUNGSBILDER

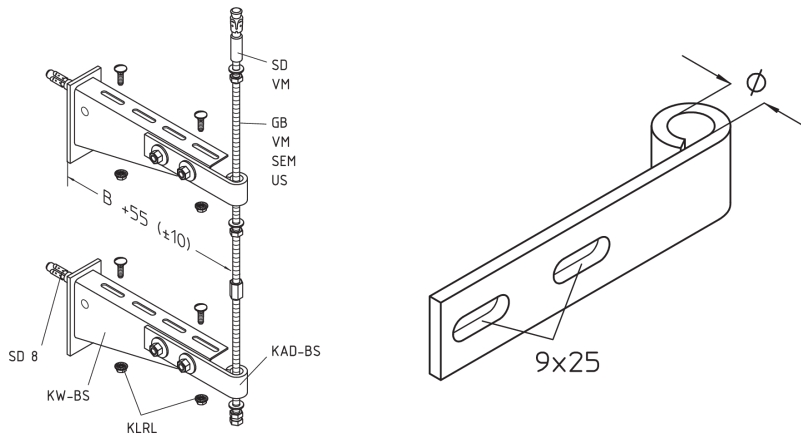

Seite 1





Brandschutz

