

BL 4

Winkellasche, LGG 60/STU-BS 50, Funktionserhalt

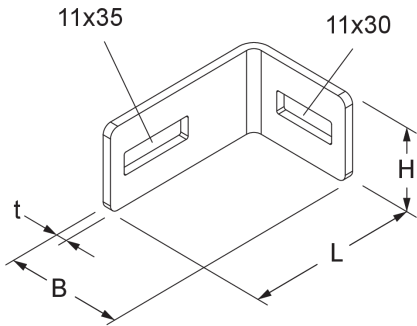

Stahl, stück-/tauchfeuerverzinkt

Artikel	H	B	L	t	Gewicht
BL 4F	40 mm	54 mm	83 mm	4,00 mm	0,149 kg

H: Höhe

B: Breite

L: Länge

t: Materialstärke

Gewicht: Gewicht je Lagereinheit

DETAIL- UND ANWENDUNGSBILDER

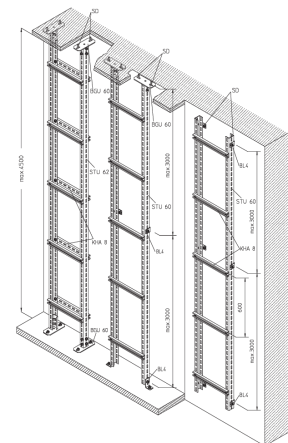
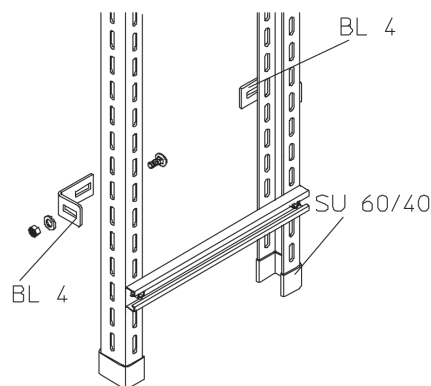
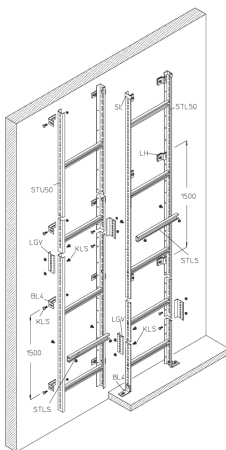

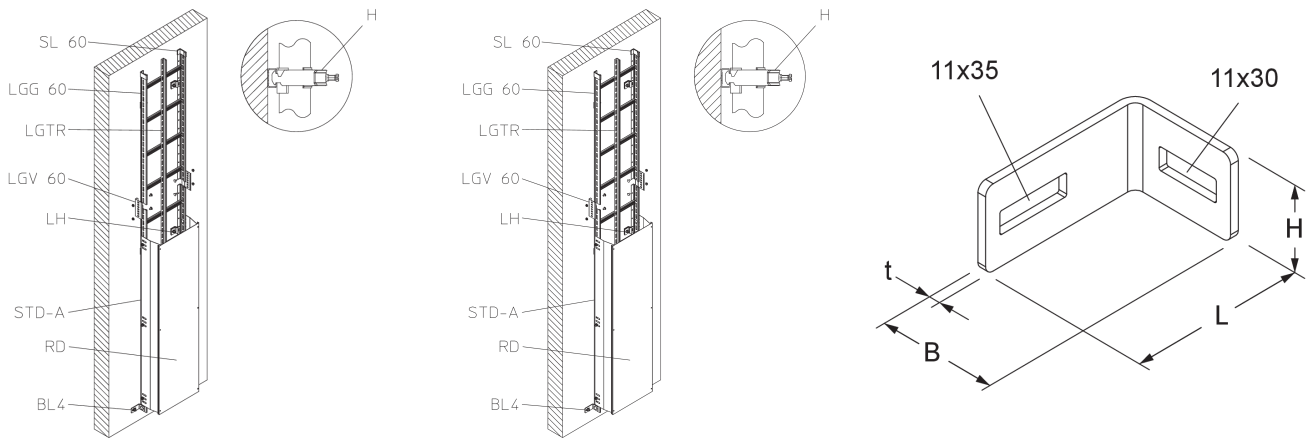

OPTIONALES ZUBEHÖR

KLS, SD

