

Screed-covered duct systems

Technical information

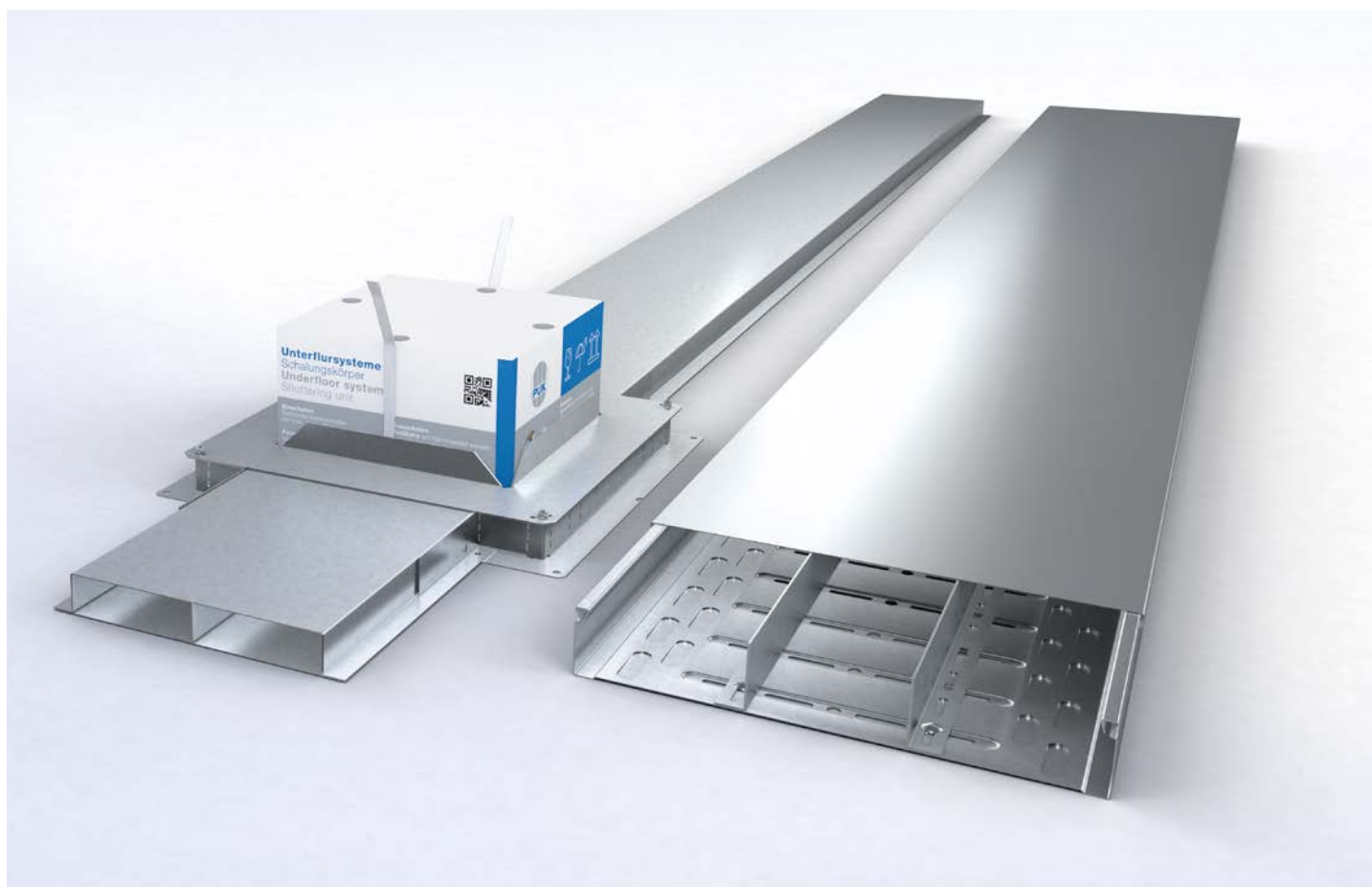

Table of contents

Screed-covered duct systems

Solutions for tomorrow's buildings 4

UK/UKL screed-covered duct

Benefits and areas of application 6

Technical data 7

System overview 8

Installation components 10

UKR cable duct system

Benefits and areas of application 12

Technical data 13

System overview 14

Installation components 16

Planning notes

Planning-relevant issues 18

Installation requirements 19

Duct system application 20

Laying cables in ducts 23

Impact noise behaviour 25

Test 26

Results 27

Installation depths 28

Fire protection 29

Service

Service 30

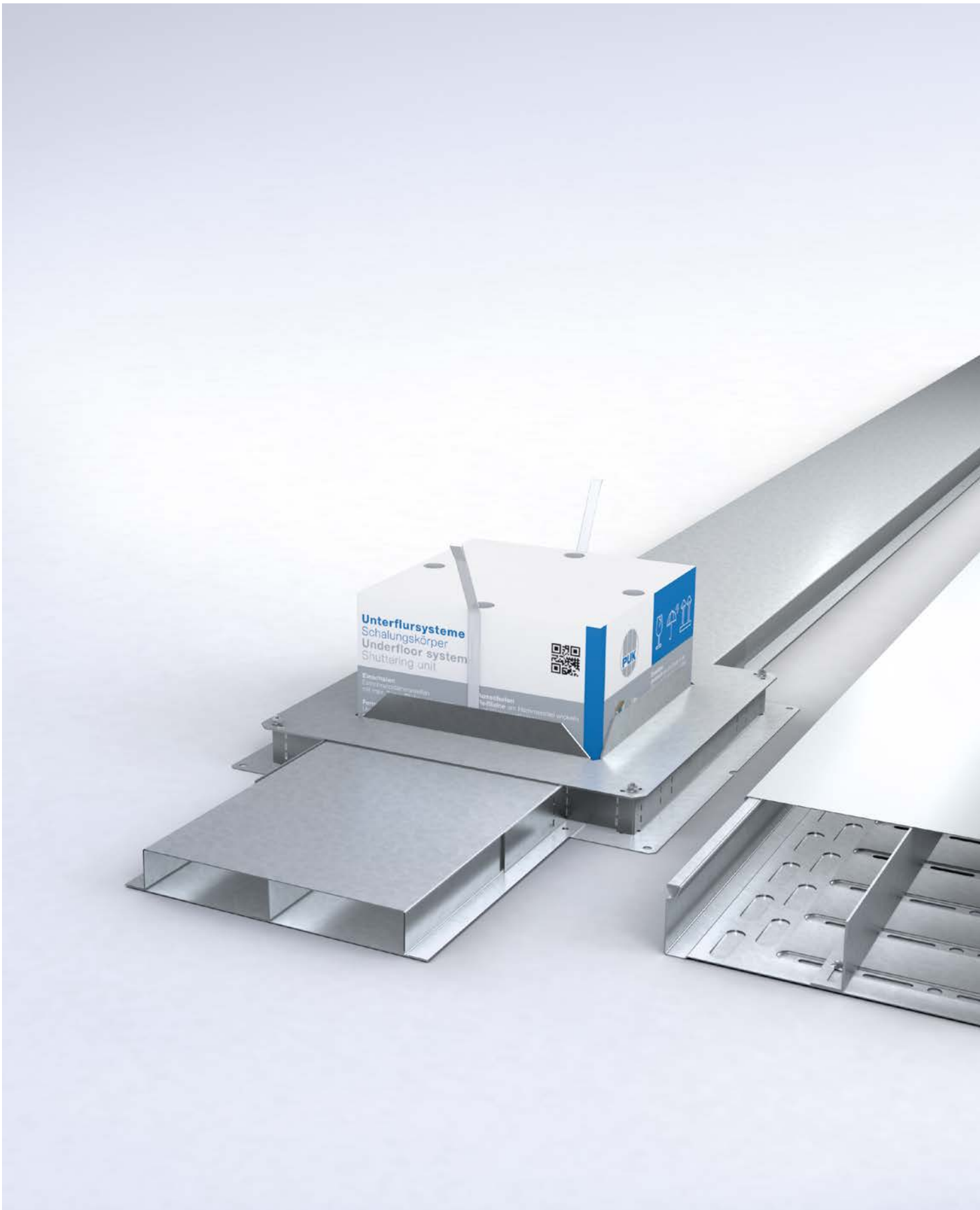



Solutions for tomorrow's buildings

Screed-covered duct systems are a universal solution that allow cables and other lines to be laid in screed. They are used to route and protect cables in rooms of various sizes. Screed-covered duct systems are the perfect choice for long-term electrical installation planning, whether for reception areas of office buildings, on entire floors of administrative buildings, or in industrial buildings.

The ducts are fastened to the slab and form the basis for all subsequent steps of installing the system. The power or data lines can be fitted before the screed is applied to protect them from external influences and to achieve a more attractive interior look. The installation space for the ducts is protected by shuttering units in floors of any thickness. These screed-covered duct systems create the ideal cavities for routing cables safely regardless of the construction tolerances. The systems comply with VDE and TÜV standards. They are also tested in accordance with DIN EN 50085.

UK / UKL

Screed-covered duct



Benefits

- High load-bearing capacity thanks to the protective screed layer
- Can be covered with insulation materials
- Can be combined with all floor boxes depending on the height and width of the duct.
- On-site assembly and length adjustment possible
- Suitable for all types of screed
- Compensates for construction tolerances

Areas of application

This underfloor duct system is designed for dry indoor spaces. The wide range of moulded parts and accessories allows the underfloor duct to be individually adapted to the respective requirements. The underfloor duct system absorbs high two-dimensional loads via the surrounding screed. This protects the cables and prevents the duct from bending.



**Technical building
equipment**



In industrial sectors

Technical data

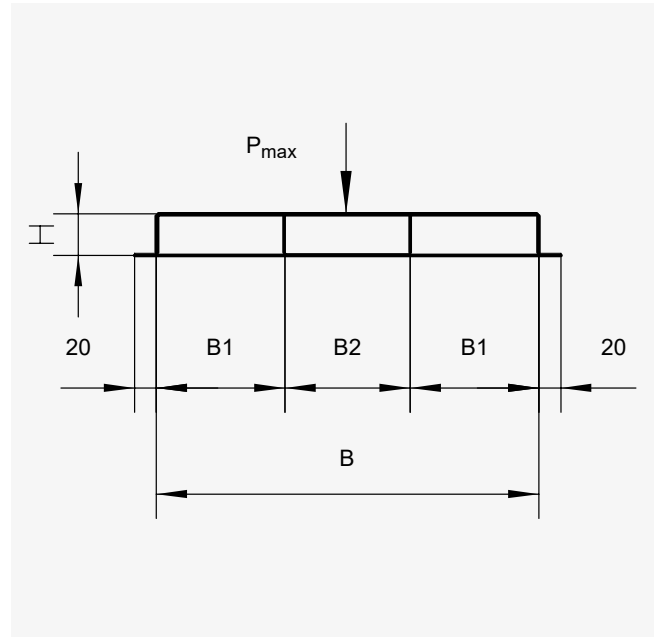
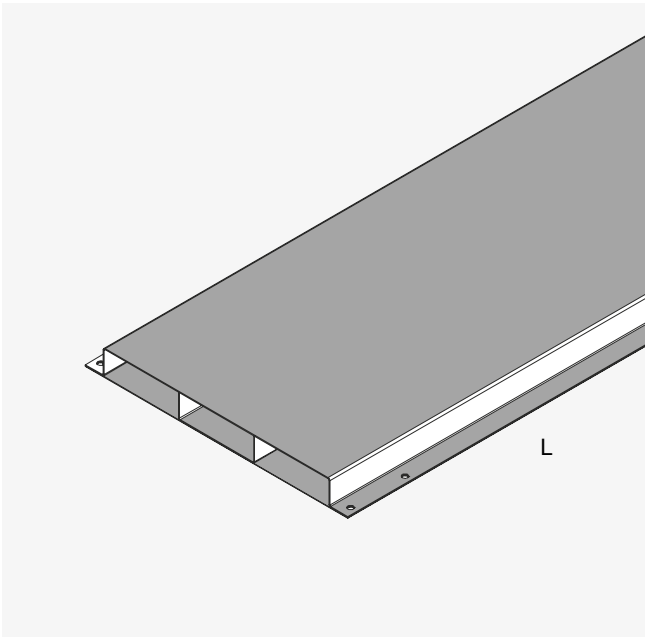

Duct (L - Length: 3000 mm, P_{max} - Maximum load: 0.75 kN)

Type	H mm	B mm	B1 mm	B2 mm	G kg
UK 2-28-190S	28	190	95	95	15.5
UK 2-28-250S	28	250	125	125	19.0
UK 2-28-350S	28	350	175	175	24.7
UK 2-38-190S	38	190	95	95	16.5
UK 2-38-250S	38	250	125	125	19.8
UK 2-38-350S	38	350	175	175	25.5
UK 2-48-190S	48	190	95	95	17.3
UK 2-48-250S	48	250	125	125	20.7
UK 2-48-350S	48	350	175	175	26.8
UKL 3-28-250S	28	250	82	84	17.9
UKL 3-28-350S	28	350	116	116	23.3
UKL 3-38-250S	38	250	82	84	18.7
UKL 3-38-350S	38	350	116	116	24.2
UKL 3-48-250S	48	250	82	84	19.7
UKL 3-48-350S	48	350	116	116	25.1

H: Height | B: Width | G: Weight

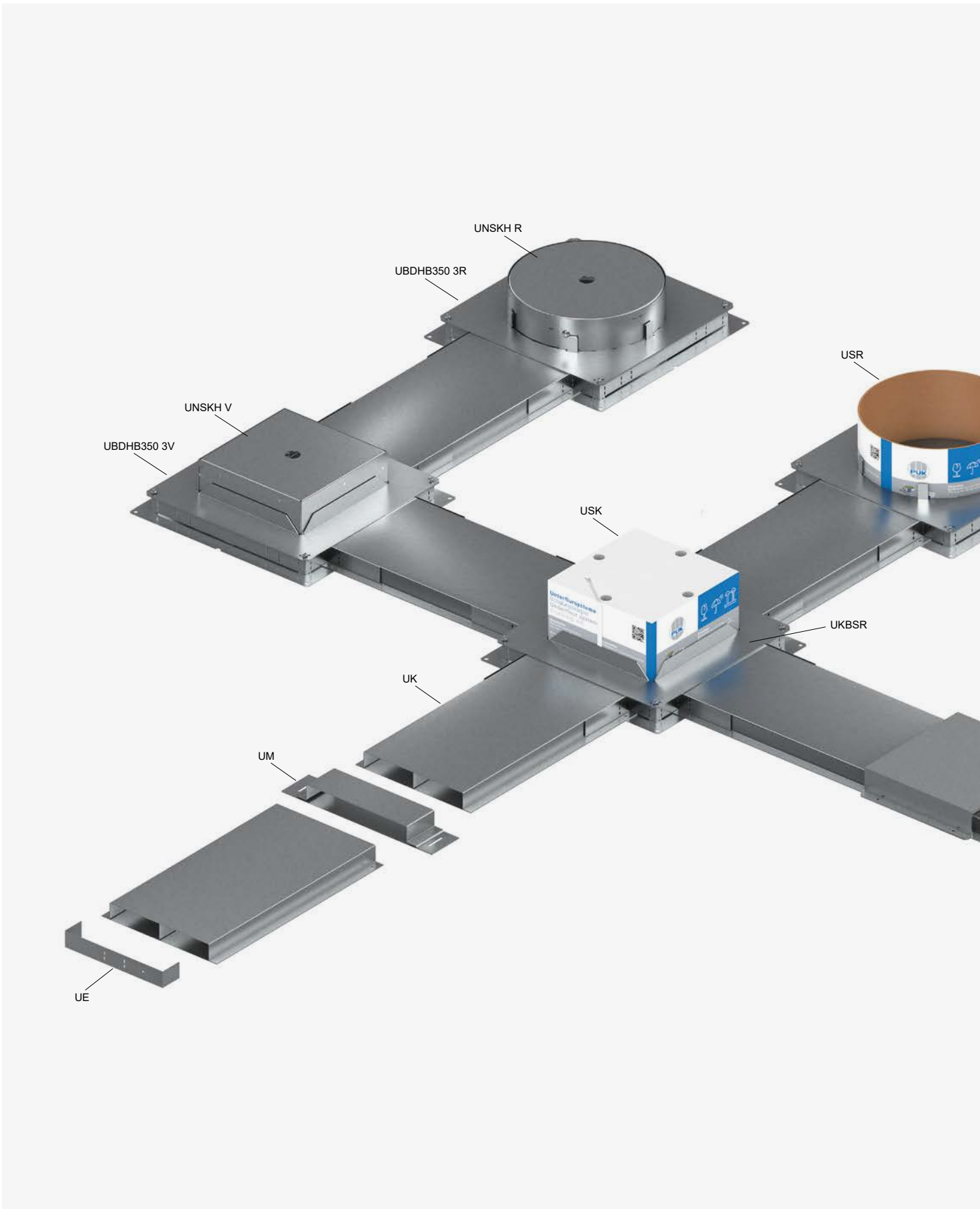

System overview

The UK underfloor duct system is always the right solution when cables need to be laid safely yet also concealed in the floor. In combination with appropriate hollow floor boxes and installation units, the system can be flexibly adapted to all local conditions and compensate for construction tolerances. Data and power lines are kept safely separated by using two-compartment or three-compartment duct designs. The top and bottom pieces are firmly connected together so the cables can be easily pulled through. The underfloor duct is positioned and anchored in place before the screed is applied to the slab, making this duct the ideal choice for invisible cable routing in screed floors.

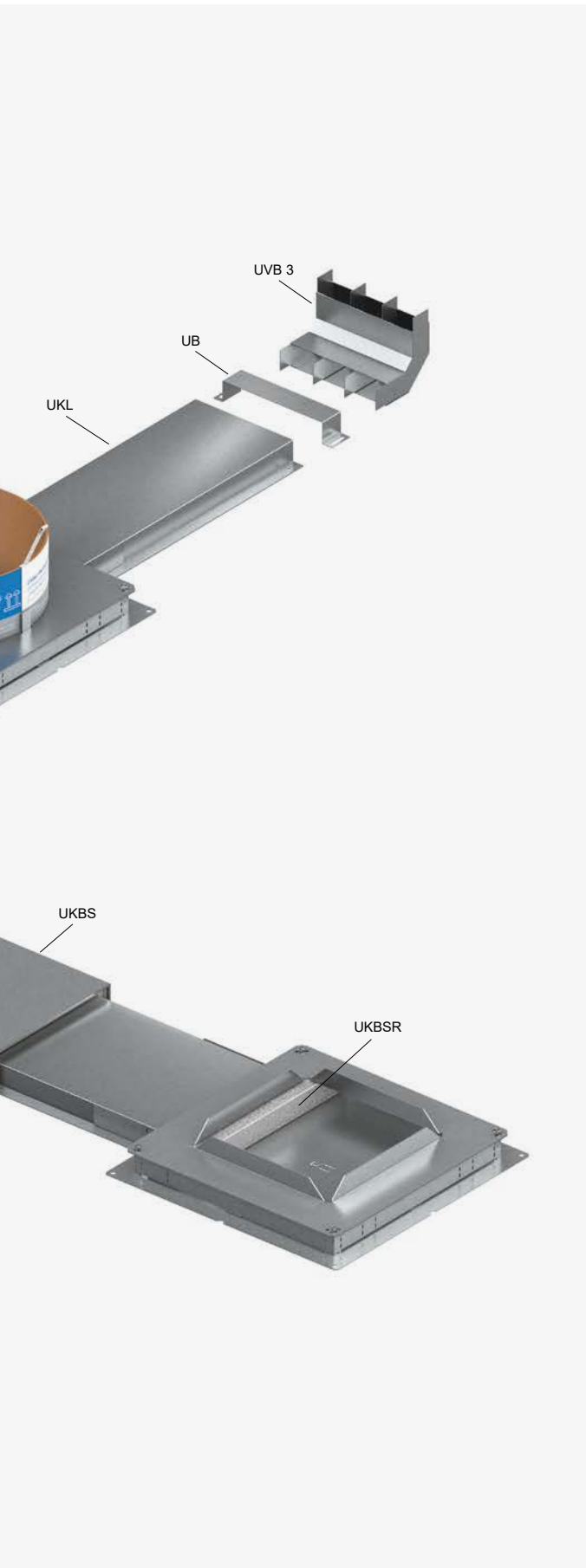

Installation components



UB
Jointing bracket



UE
End pieces

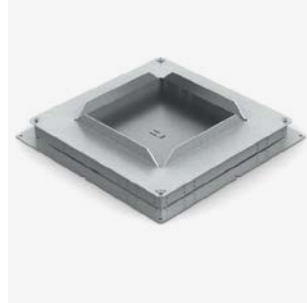

UBDHB V
Hollow floor box, square



UBDHB R
Hollow floor box, round



UKBS
Fire-resistant partition



UKBSR
EasyFoam foam plugs



USK
Shuttering unit, square



USR
Shuttering tube, round

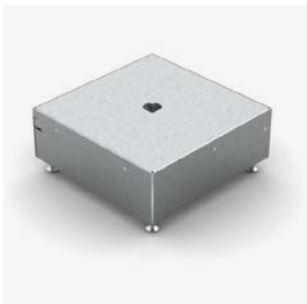

UNSKH V
Heat-resistant shuttering unit, height-adjustable, square



UNSKH R
Heat-resistant shuttering unit, height-adjustable, round

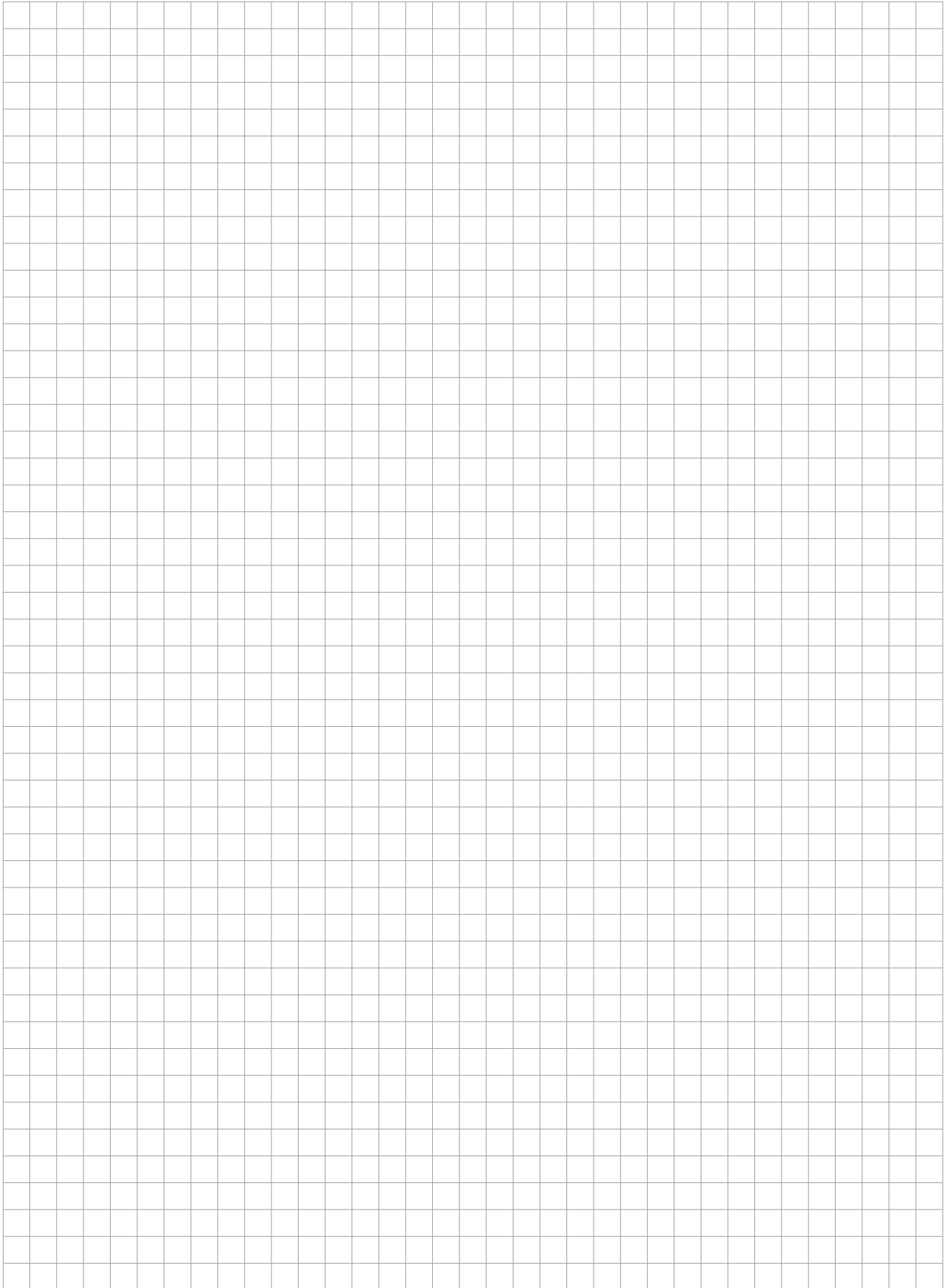

UKR

Cable duct system



Benefits

- Suitable for large volumes of cable thanks to variable side rail heights and widths
- Set up the system directly on site
- Cables and lines can be laid before the screed is applied.
- Suitable for all types of screed
- Customisable on request
- Compensates for construction tolerances

Areas of application

This screed-covered cable duct system is the suitable model for laying large quantities of cables in buildings. The duct and cover combination makes it easy to insert cables into the system. The duct is subsequently closed using the corresponding covers. This screed-covered cable duct system is designed for use in dry rooms wherever large quantities of cables need to be managed.



**Technical building
equipment**



In industrial sectors

Technical data

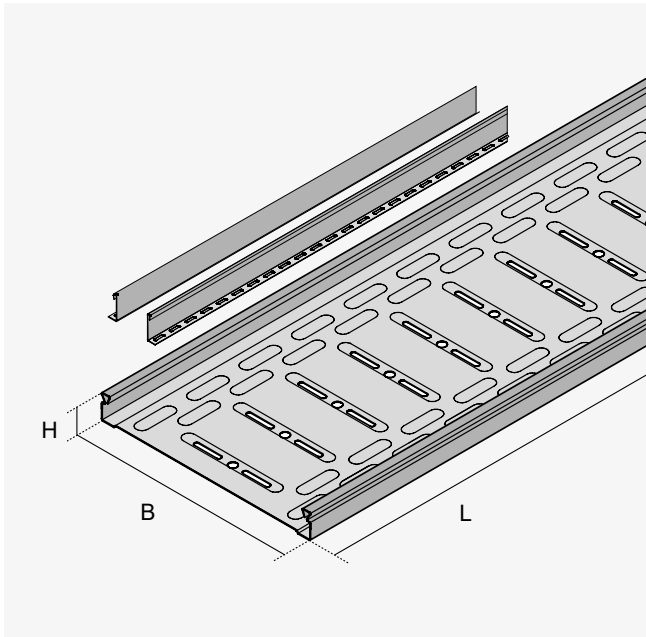

Duct (Length: 3000 mm)

Type	H mm	B mm	G kg
UKR 35-30S	35	300	8.9
UKR 35-40S	35	400	14.2
UKR 35-50S	35	500	15.4
UKR 60-40S	60	400	19.8
UKR 60-50S	60	500	23.9
UKR 85-40S	85	400	23.4
UKR 85-50S	85	500	27.5
UKR 110-40S	110	400	28.7
UKR 110-50S	110	500	31.0

B: Width | E: Installation dimension | G: Weight



System overview

Various combinations of separating strips and covers creates a flexible system for routing cables in the floor. The cable duct is firmly anchored to the slab using the separating strips before the screed is applied. The cables can be easily inserted from above. The system is then closed using the corresponding covers. The cable duct can accommodate large quantities of cables and lines and can therefore be flexibly adapted to changing conditions regardless of how the room is used or the type of screed being laid.

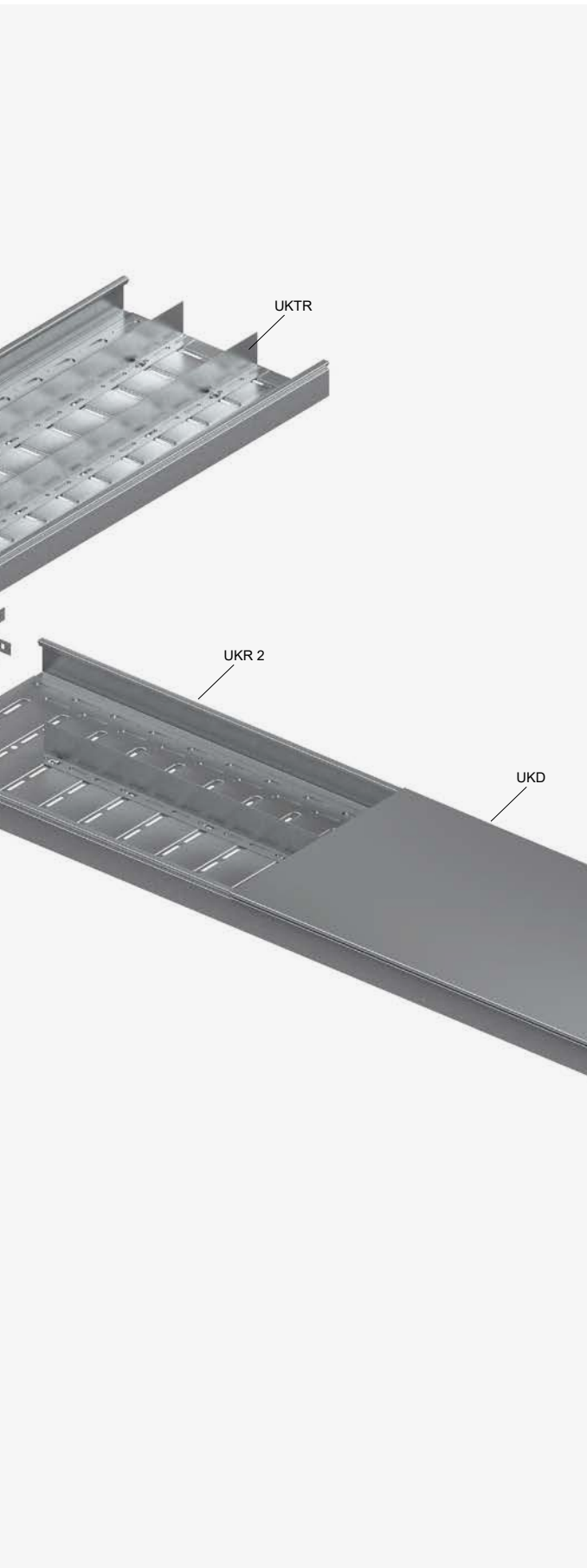

Installation components



UKD
Cable duct dummy cover



UKEB
End piece



UKDA V
Cable duct assembly cover,
square

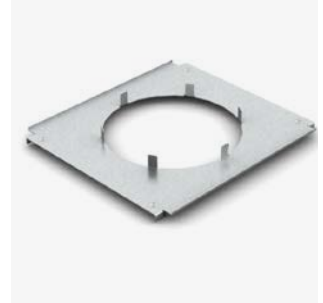

UKDA R
Cable duct assembly cover,
round



UKTR
Separating strip



USK
Shuttering unit, square



USR
Shuttering tube, round

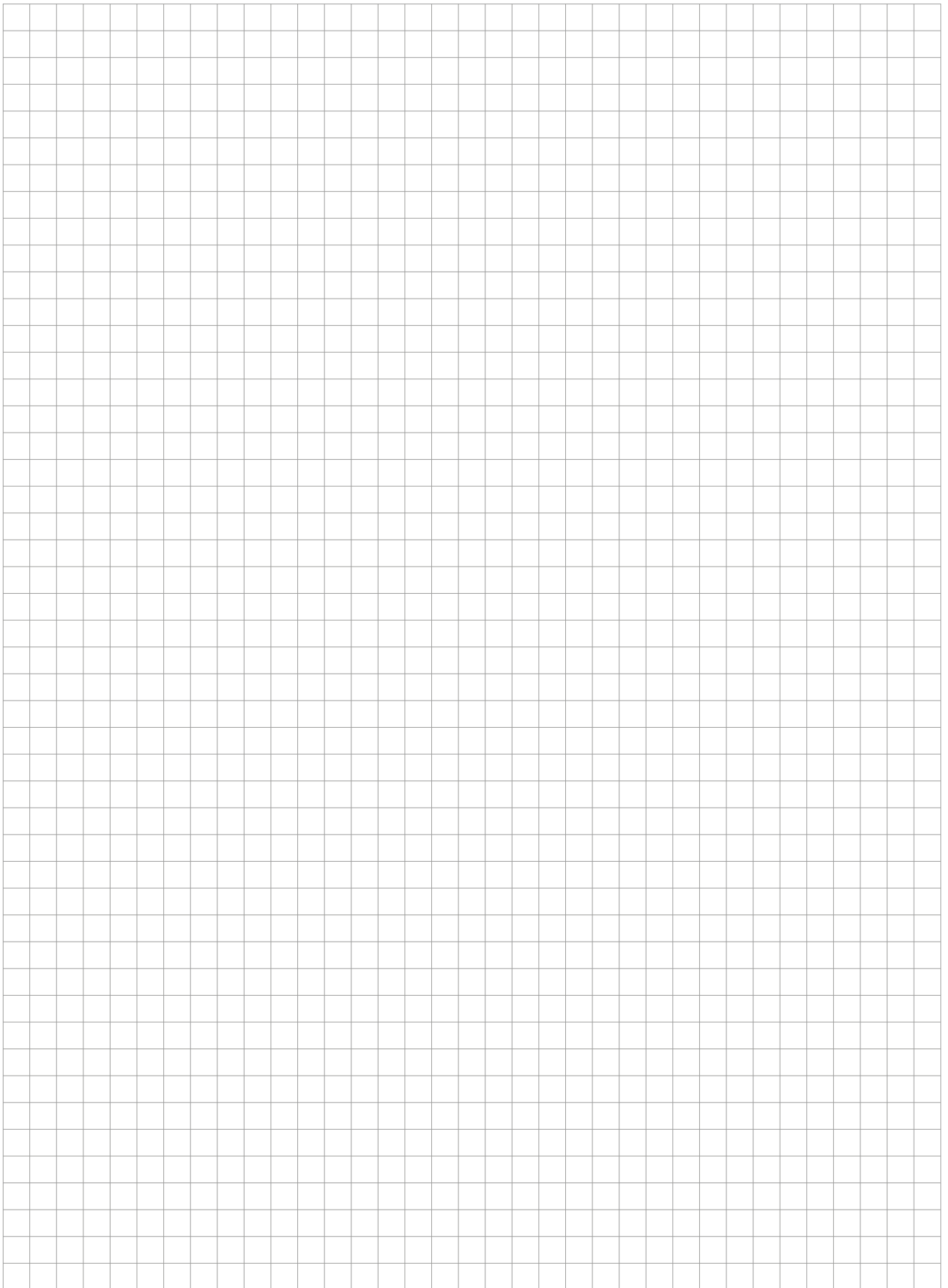

Planning notes

Planning-relevant issues

1. Floor structure

- Height from bare concrete to top of screed mm
- Floor covering thickness mm
- Total floor structure mm
- Screed thickness mm

3. Screed types

- Screed
- Mastic asphalt

4. System resilience

- Office traffic loads
- Heavy loads

5. Floor covering

- Carpet
- Linoleum
- Parquet
- Stone
- Poured asphalt
- Other:

6. Flooring cleaning method

- Dry-cleaned rooms
- Wet-cleaned rooms

7. Shape of the installation units

- Round
- Square

8. Material

- Stainless steel
- Plastic

9. Fittings

- Number of powered devices installed: units
- Number of data technology devices installed: units

Installation requirements

On-site requirements

The following requirements must be met before an underfloor duct system can be properly installed:

- Approved dimensioned installation plan specifying the location of all installation parts
- Project bill of materials listing the materials to be used
- Floor construction and flooring documents
- A broom-clean, approved slab within the construction tolerances according to DIN 18 202 (see appendix 2).
- Accurate benchmarks as reference points for the appropriate screed thickness
- Information on traffic loads, fire protection measures and impact noise behaviour
- The assembly area must be free of rubble and foreign materials
- The area must be well protected against weather and moisture
- Minimum installation depth and floor care of installation units must be specified

Screed work

Ducts and their accessories are components that only gain their full load-bearing capacity for their intended use once they are firmly bonded to the screed. Specifically, the following points are essential to ensure successful installation:

- The duct system must be sealed before applying the screed.
- The system elements must be firmly anchored to the slab
- The installed duct system must not be walked on or otherwise subjected to stress
- There must be a firm bond between the duct system and screed
- Any cavities must be filled in with screed
- Ensure that the screed is well compacted and flush in the area of the floor boxes to prevent any unevenness or cracks in the screed later on.
- Loads can only be applied to the duct system once the screed has hardened and the area must be cordoned off while curing. Screed deformations and shrinkages must be taken into account in advance

You must not use insulation strips to decouple the duct system from the screed, as this may result in the screed or duct being damaged or the floor covering cracking. Screed types and minimum screed thickness must be complied with according to DIN 18 560-2 (see appendix 1). This specifies a screed thickness of at least 40 mm over the duct for office and work areas with a surface load of up to 2 kN/m².

For higher loads, correspondingly thicker screeds must be applied in accordance with DIN 18560. The duct system itself has been loaded and tested with a point load of 750 N in accordance with the standard.

When using self-levelling screeds, all standard openings < 7 mm must be professionally masked off.

Mastic asphalt

When using mastic asphalt, please note:

- The duct system must be protected from the high installation temperatures using suitable insulation layers.
- If the insulation layers are > 2 mm, the insulation strip between the shuttering unit and the asphalt must be removed after the mastic asphalt has cooled down and the resulting gap must be filled flush with the surface using suitable materials.
- The shuttering unit must be removed after the material has cured.

Duct system application

The underfloor system must comply with the requirements of DIN EN 50085. The duct system must be installed on the slab according to the assembly instructions and in compliance with the technical information.

When using hollow floor boxes with shuttering units, please note:

- Protect the components against moisture and mechanical damage
- Pre-assemble firmly and vertically in the floor box
- Spray with shuttering oil before applying the screed
- Only use separating membranes <2 mm thick to decouple the floor box from the screed.
- Apply the screed cleanly
- Only use each shuttering unit once

The floor boxes can be used in floors with the following minimum screed thicknesses:

Name	Duct height mm	Minimum thickness mm	Usage
UBDHB350/250 28	28	65	Junction box
UBDHB350/250 38	38	75	Junction / flush-mounted box
UBDHB350/250 48	48	85	Junction / flush-mounted box

The screed-flush duct system requires a minimum floor thickness of 60 mm.

Including the duct system in protective measures

- All metallic parts of the entire duct system must be included in the protective measures
- According to the VDE, all conductive parts of the duct system must be included in the equipotential bonding arrangement. This is done at the transition points of the components by welding, riveting, making a firm pressure connection using screw connectors or using flexible earthing conductors.
- The electrical duct system must not be used as an equipotential bonding conductor
- The duct system must be included in the equipotential bonding arrangement of the entire system during the electrical installation work
- When using insulated sheathed cables, it is sufficient to include only the floor boxes in the protective measures. A protective conductor terminal is provided on every floor box for this purpose
- When laid over expansion joints, care must be taken to ensure that connections between the components are flexible

The declared linear impedance for UK electrical installation duct lengths is 0.001 ohms per metre.

Floor coverings

When selecting flooring materials, consider that underfloor installation systems are subject to the effects of live loads and must be classified by means of test loads of 500 N to 15,000 N in accordance with DIN EN 500 85. Dynamic deflections of up to 6 mm and permanent deformations of up to 3 mm are permitted.

Flatness specifications for finished floors according to DIN 18202 tab. 3 line 3 must be complied with.

Sufficiently thick, self-supporting layers of exposed concrete, synthetic resin and poured asphalt coverings, as well as tiles or natural stone, prevent subsequent cracking of the covering under changing dynamic loads.

Even slight deflections can damage thin, hard floor coverings, such as tiles. Thick floor coverings, such as granite flags, increase the load capacity of the underfloor system, resulting in better load distribution.

Appendix 1: Excerpt from DIN 185602:200909

Table 1: Nominal thicknesses and flexural tensile strength or hardness of unheated screeds on insulation layers for vertical live loads $\leq 2 \text{ kN/m}^2$

Screed type	Bending strength class or hardness class according to DIN EN 13813	Nominal screed thickness ^a mm with compressibility of the insulation layer ^{c,d} $\leq 5 \text{ mm}^b$	Confirmation test of flexural strength βBZ N/mm^2		Penetration depth mm	
			Smallest single value	Average value	At $22 \pm 1^\circ\text{C}$	At $40 \pm 1^\circ\text{C}$
Calcium sulphate self-levelling screed (CAF)	F4	≥ 35	≥ 3.5	≥ 4.0	-	-
	F5	≥ 35	≥ 4.5	≥ 5.0	-	-
	F7	≥ 35	≥ 6.5	≥ 7.0	-	-
Calcium sulphate screed (CA)	F4	≥ 45	≥ 2.0	≥ 2.5	-	-
	F5	≥ 40	≥ 2.5	≥ 3.5	-	-
	F7	≥ 35	≥ 3.5	≥ 4.5	-	-
Poured asphalt	IC10	≥ 25	-	-	≤ 1.0	≤ 4.0
	ICH 10	≥ 35	-	-	≤ 1.0	≤ 2.0
Synthetic resin screed	F7	≥ 35	≥ 4.5	≥ 5.5	-	-
Magnesium screed MA	F4	≥ 45	≥ 2.0	≥ 2.5	-	-
	F5	≥ 40	≥ 2.5	≥ 3.5	-	-
	F7	≥ 35	≥ 3.5	≥ 4.5	-	-
Cement screed CT	F4	≥ 45	≥ 2.0	≥ 2.5	-	-
	F5	≥ 40	≥ 2.5	≥ 3.5	-	-

A. For insulation layers $\leq 40 \text{ mm}$, the screed thickness can be reduced by 5 mm for calcium sulphate, synthetic resin, magnesium and cement screeds. The minimum thickness must not be less than 30 mm (except poured asphalt).

B. For poured asphalt screeds, the compressibility of the insulation layers must not exceed 3 mm.

C. The surface hardness of xylolite screeds must be at least SH 30 according to DIN EN 13813.

D. For higher compressibility ($\leq 10 \text{ mm}$), the nominal screed thickness must be increased by 5 mm.

Appendix 2: Excerpt from DIN 18202

Table 3: Flatness tolerances

Column		1	2	3	4	5	6
Row	Reference	Depth gauges as limit values in mm for test point spacings in m up to					
		0.1	1 ^{A)}	4 ^{A)}	10 ^{A)}	15 ^{A) B)}	
1	Non-surface-finished topsides of ceilings, concrete subbases and subfloors	10	15	20	25	30	
2	Non-surface-finished topsides of ceilings, concrete subbases and subfloors with more stringent requirements, e.g. to accommodate floating screeds, industrial floors, tiles and flags, composite screeds. Fully finished surfaces for simple purposes, e.g. in storerooms, cellars	5	8	12	15	20	
3	Surface-finished floors, e.g. plain screeds, screeds for receiving floor coverings; floor coverings, tiled coverings, trowelled and bonded coverings	2	4	10	12	15	
4	As row 3, but with more stringent requirements	1	3	9	12	15	
5	Non-surface-finished walls and undersides of slabs	5	10	15	25	30	
6	Surface-finished walls and undersides of ceilings, e.g. plastered walls, wall coverings, suspended ceilings	3	5	10	20	25	
7	As row 6, but with more stringent requirements	2	3	8	15	20	

A. Intermediate values are to be taken from figures 1 and 2 and rounded to whole millimetres.

B. The flatness tolerances in column 6 also apply to test point spacings over 15 m.

C. Reproduced with the permission of DIN Deutsches Institut für Normung e. V. The last-issued version of the DIN standard must be applied and can be obtained from Beuth Verlag GmbH, Burggrafenstrasse 6, 10787 Berlin, Germany.

Laying cables in ducts

The cable volume must be determined as a basis for your plans. The cross-sections of the selected, commercially available types of cables are average values. Calculations are based on a maximum duct fill factor of 60% with a maximum floor box spacing of 8 m. Note the reduction in cross-section due to the installation depth of the mounting box and installation unit.

See DIN VDE 0100/0298 for the current rating.

Minimum installation cross section of an installation unit

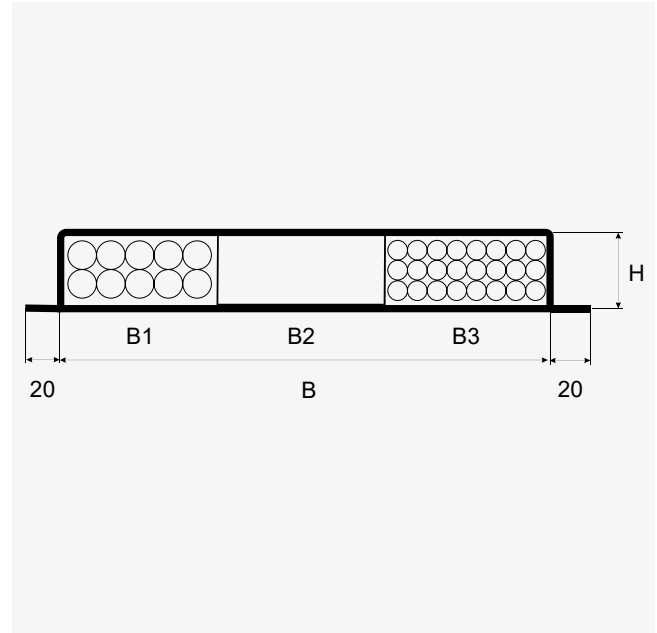

B1 & B3 / power line 3 x 2.5 mm, useful cross section cm² = 1,
B2 / Cat.6 data line, useful cross section cm² = 0.64

Type	H mm	B mm	A cm ²	B1 mm	B2 mm	B1 / B3 power line 3 x 2.5 mm ² / B2 / Cat.6 data line	
						Number of dia. 10 mm	Number of dia. 8 mm
UK 2-28-190S	28	190	53	95	95	16	25
UK 2-28-250S	28	250	70	125	125	21	33
UK 2-28-350S	28	350	98	175	175	29	45
UK 2-38-190S	38	190	72	95	95	21	33
UK 2-38-250S	38	250	95	125	125	28	44
UK 2-38-350S	38	350	133	175	175	39	62
UK 2-48-190S	48	190	91	95	95	27	42
UK 2-48-250S	48	250	120	125	125	36	56
UK 2-48-350S	48	350	168	175	175	50	78
UKL 3-28-250S	28	250	70	82	84	14	22
UKL 3-28-350S	28	350	98	116	116	19	30
UKL 3-38-250S	38	250	95	82	84	19	30
UKL 3-38-350S	38	350	133	116	116	26	41
UKL 3-48-250S	48	250	120	82	84	24	37
UKL 3-48-350S	48	350	168	116	116	33	52

Minimum installation cross section of an installation unit

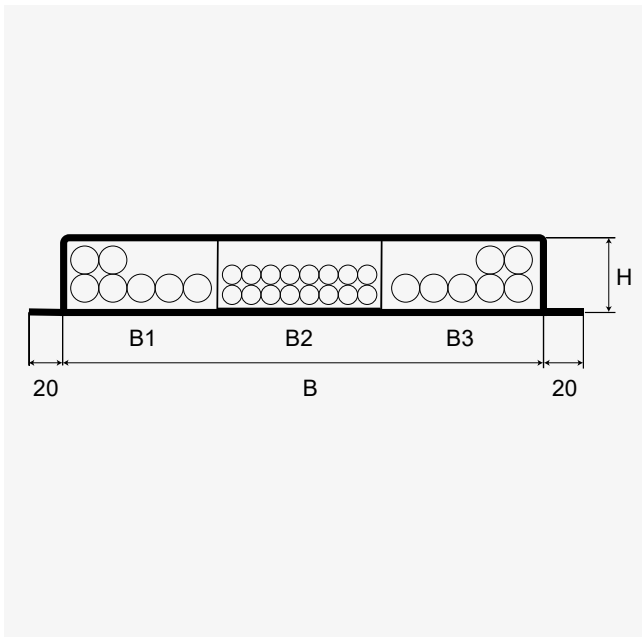

**B1 & B3 / power line 3 x 2.5 mm, useful cross section $\text{cm}^2 = 1$,
 B2 / Cat.6 data line, useful cross section $\text{cm}^2 = 0.64$**

Type	H mm	B mm	A cm^2	B1 mm	B2 mm	B1 / B3 power line 3x2.5 mm ²	B2 / Cat.6 data line
						Number of dia. 10 mm	Number of dia. 8 mm
UKR 35-30S	35	300	105	149	149	31	49
UKR 35-40S	35	400	140	132	132	28	43
UKR 35-50S	35	500	175	165	165	35	54
UKR 60-40S	60	400	240	132	132	48	74
UKR 60-50S	60	500	300	165	165	59	93
UKR 85-40S	85	400	340	132	132	67	105
UKR 85-50S	85	500	425	165	165	84	131
UKR 110-40S	110	400	440	132	132	87	136
UKR 110-50S	110	500	550	165	165	109	170

H: Height | B: Width | A: Cross section

Impact noise behaviour

Sound insulation when using underfloor duct systems

The requirements for sound insulation in buildings are regulated by DIN 4109. The aim is to minimise noise pollution. The best way to achieve this is to acoustically decouple the slab, the duct system and the screed by using isolation layers. Floating screeds can also be used to acoustically isolate the floor. Otherwise, structure-borne sound excitation is transmitted directly via the slab. In this case, footfall noise can only be reduced by installing soft, elastic floor coverings.

Measurement procedure for underfloor duct systems

The impact sound behaviour of the screed-covered systems is measured between two rooms positioned one above the other with structure-borne flank transmission. Measurements are conducted in a footfall sound test facility according to DIN 522102 or DIN EN ISO 10140 and the tests themselves comply with DIN EN ISO 1407 or DIN EN ISO 162832.

A standard tapping machine is used as a sound source in the transmitter room. The noise is generated by tapping both on the screed and directly on the duct or installation unit.

We work exclusively with testing laboratories that comply with DIN EN ISO/IEC 17025.

The received levels are determined using a real-time analyser and rotating microphone. The standard impact sound level $L^{\prime}_{n,w}$ is calculated as the characteristic value of the component being assessed taking into account the volume and the reverberation time.

The impact sound reduction ΔL_w is calculated as the difference between the standard impact sound level of a ceiling with and without floor coverings. The impact sound reduction must be effective enough to ensure that the maximum standard impact sound level stipulated for office buildings is not exceeded. The standard impact sound level values required in office buildings are defined as follows:



Normal impact sound level requirements

$L^{\prime}_{n,w} \leq 53$ dB (DIN 4109)

More stringent impact sound level requirements (recommendations)

$L^{\prime}_{n,w} \leq 46$ dB (DIN 4109)

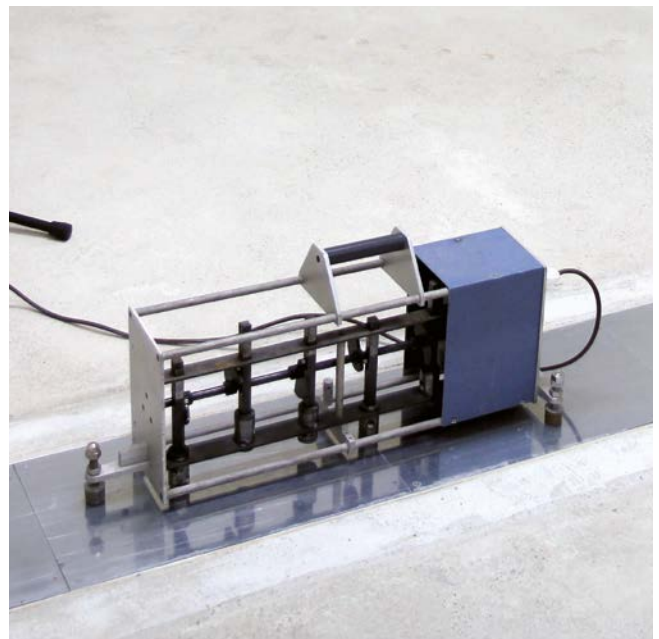

Test

UKL duct, UBDHB350 V hollow floor box with square UEKD3 V plastic installation unit

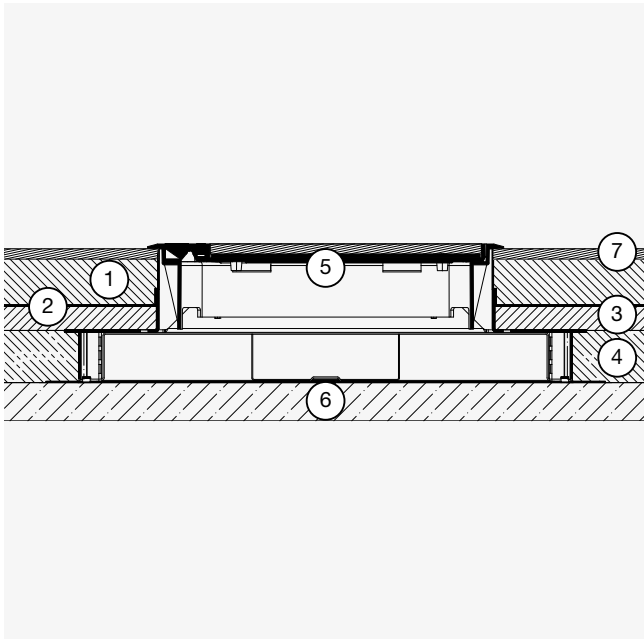

UKL duct, UBDHB350 V hollow floor box with UEKD V E square stainless steel installation unit mounted on UNE levelling unit

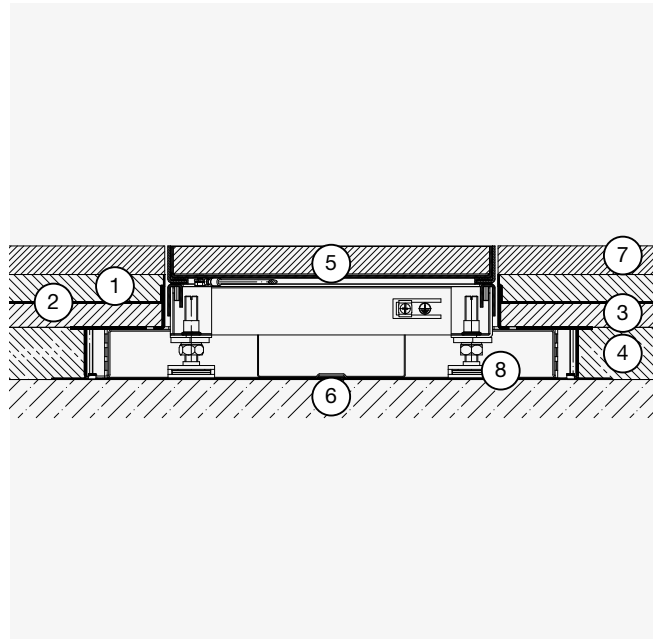

Test setup

	ΔL_w (dB) mm	$L'_{n,w}$ (dB) kN/m
Duct system installed in floating screed, sound excitation on screed and duct	29	52
Duct system installed in floating screed, sound excitation on screed with textile floor covering	40	41
Duct system installed in floating screed, sound excitation on installation unit with textile floor covering	46	35

Test setup

	ΔL_w (dB) mm	$L'_{n,w}$ (dB) kN/m
Duct system installed in floating screed, sound excitation on stainless steel unit with parquet	28	53
Duct system installed in floating screed, sound excitation on screed and duct, decoupled by rubber bushing	31	50

Results

Transmission room with carpet floor covering

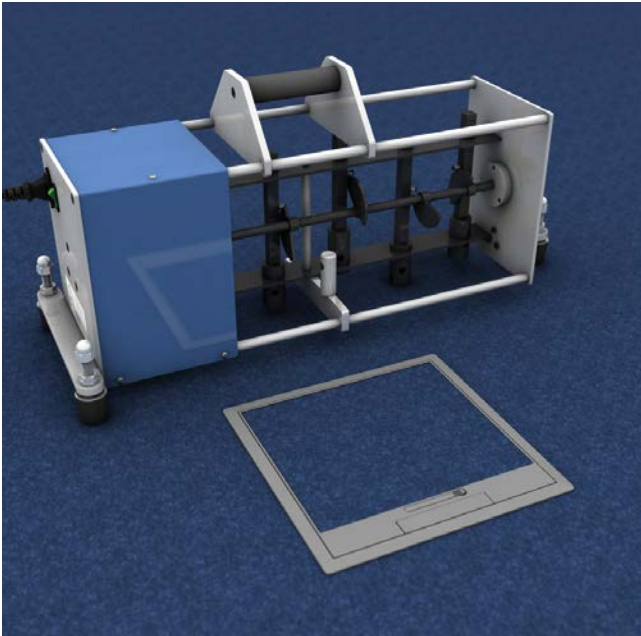

Transmission room with parquet floor covering

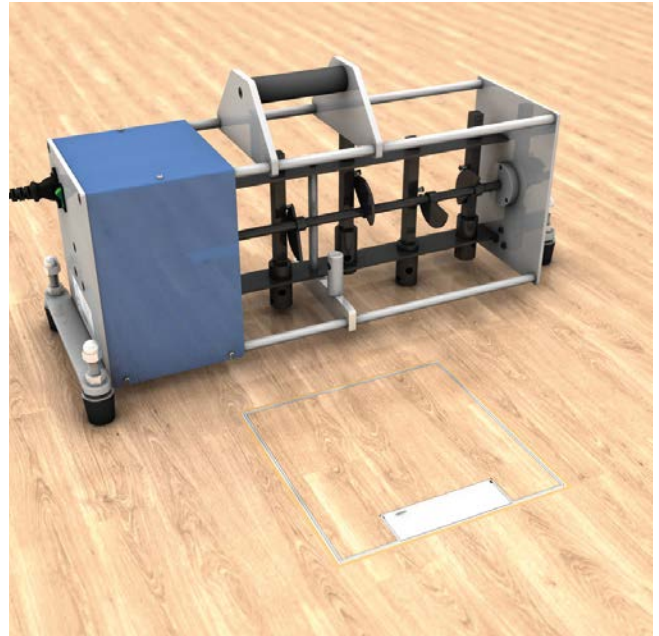

The measurement results show that the screed-covered underfloor system meets the requirements of normal sound insulation of 53 dB for ceilings in office buildings in all application-specific tests. Underfloor systems can be installed in the floating screed of a ceiling without any problems related to impact sound behaviour.

If the levelling system is additionally decoupled from the slab by means of rubber bushings, impact sound is reduced by 3 dB in comparison with the levelling system mounted directly on the slab. The advantage of the hollow floor box is that it is completely mechanically decoupled from the duct system. This is particularly evident when using parquet, stone, poured asphalt coverings or exposed concrete.

Structure

1. 50-mm cement screed
2. 1-mm membrane
3. 20-mm impact sound insulation panel
4. 40-mm thermal insulation panel
5. Installation unit
6. 160-mm slab
7. Floor covering
(carpet: 8.0 mm, parquet: 12.0 mm)
8. UGM rubber bushing

$L_{n,w}^{\sim} = 81$ dB sound excitation on slab

$L_{n,w}^{\sim} = 50$ dB sound excitation on screed
without installations

Installation depths

General requirements

For underfloor electrical installation duct systems, the thickness of the floor structure essentially determines the space available to install the installation unit, mounting box and installation device.

It must be possible to close the cover or the cassette when in use to meet the minimum requirements of protection class IP 20 according to DIN EN 50085. These factors are used to calculate the minimum installation height required for the system when using angled and straight plugs for data or power technology.

Technical notes

The minimum installation depths determined by us refer to the minimum dimensions of commercially available plugs for power technology indicated in the figures.

The installed mounting boxes or device supports can be lowered in steps by up to 30 mm by using snap-in ladders in the corresponding plastic and stainless steel installation units. This presupposes that sufficient space is available under the installation unit and is not blocked by power cables or data technology cables. It is particularly important to consider the thickness of the cables when using screed-covered duct systems.

Minimum installation depths of system components

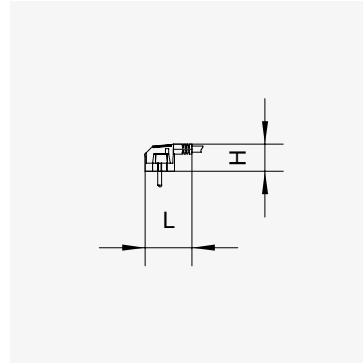

Angled plug
Height = 33 mm
Length = 58 mm

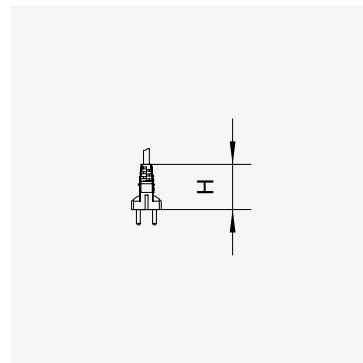

Straight plug
Height = 55 mm

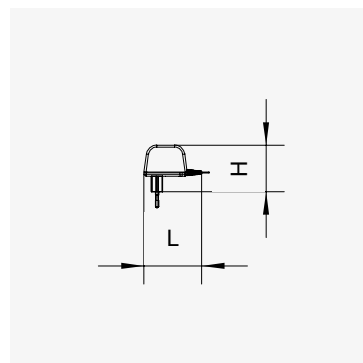

Mains adaptor
Height = 58 mm
Length = 71 mm

Fire protection

General information

The fire behaviour of building materials and components is regulated by DIN 4102-9. Part 9 regulates fire testing of cable penetration insulation.

DIN 4102 does not stipulate fire resistance properties. These are stipulated in the building regulations of the German federal states and in other directives, such as industrial construction guidelines. If a fire resistance rating is prescribed for a wall, cables may only be routed through it if there is no risk of fire propagation or precautions have been taken against this. With regard to the use of electrical installation duct systems, this means that if fire protection walls are crossed, they must then be sealed against fire and flue gas.

Wichmann cable penetration insulation

Using the approved Wichmann WD 90 cable penetration seal system prevents fire and smoke from being transmitted through installation openings in fire protection walls for a fire resistance duration of 90 minutes. The partition consists of a box containing fire protection packages that begin to expand at a temperature of 100°C in case of fire and separate EasyFoam plugs to seal against smoke. Proper installation and handling must be observed in accordance with the relevant national technical approval.

This results in the following advantages for the user when used in duct systems:

- Use of an open partition in the fire protection wall
- Separate flue gas seal in the floor box
- Easy assembly and subsequent installation
- The duct system can be installed within the thermal and impact sound insulation

System requirements

- Test standard: DIN 4102-9
- Fire resistance class: S90
- Approval: Z-19.15-202
- Proof of usability: Approval with manufacturer's certificate

After assembling the system according to the following assembly instructions, a corresponding manufacturer's certificate must be requested confirming for the building owner that this installation variant deviates only insignificantly from the approval according to the building regulations. If executed correctly, the system would then comply with the approval.

Model conduit systems directive (MLAR)

Point 3.5.6 of the MLAR guidelines on fire protection behaviour states the following:

"Underfloor ducts flush with or covered by screed for the installation of cables must have a top cover of non-combustible building materials in necessary stairwells, in rooms between necessary stairwells and exits to the outside and into necessary corridors. They shall have no openings, except for inspection openings or revision openings in necessary corridors with tightly sealed closures made of non-combustible building materials."

It is vital that hollow floors have at least 30 mm of screed above underfloor ducts.

Our synergy concept for your benefit

With us, you can take advantage of the collective experience of three established manufacturers that combine products and expertise in one comprehensive offer. That is the PohlCon synergy concept.



Full service consulting

Our extensive network of consultants is available to answer all of your questions about our products on site. From planning to deployments, enjoy personal support from our qualified professionals.



Digital solutions

Our digital offerings offer targeted support in planning with our products. From tender texts through CAD details and BIM data to modern software solutions, we offer you tailored support for your planning.



7 areas of application

We think in holistic solutions, which is why we have grouped our products into seven areas of application for you where you can benefit from the synergy of the PohlCon product portfolio.

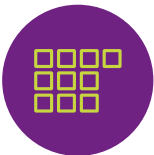

10 product categories

To help you find the right product in our extensive range even faster, the products are grouped into ten product categories so you can navigate clearly between our products.



Individual special solutions

There's no mass produced-product on the market that is suitable for your project? We master extraordinary challenges with the many years of expertise of our three manufacturing brands in the sector of individual solutions, allowing us to realize your unique construction projects together.



All rights reserved. Reprinting and any electronic reproduction only authorised with our written permission. Errors excepted and subject to technical changes. No liability can be accepted by the publisher on any legal basis whatsoever. This publication supersedes all previous versions of the document, thereby rendering them invalid.

PohlCon GmbH

Nobelstr. 51
12057 Berlin
Germany

T +49 30 68283-04
F +49 30 68283-383

www.pohlcon.com