

Screed-flush duct system UBSF

Assembly instruction





Notes

- We recommend first aligning the duct, then fixing it to the unfinished floor and then loosening the transport lock.
- Centre support only for the widths 400, 500 and 600 mm.
- Standard delivery length of the covers is 1 m. On request 0.5 m.
- Covers are supplied separately and not screwed on.
- Separators are optional.
- Observe torque values according to DIN EN 50085-1: M4: 1.2 Nm; M5: 2.0 Nm
- The duct system must be included in the equipotential bonding. The UEBSEL set can be used for this purpose.



Required tools

- Laser/spirit level
- Folding ruler
- Marking tool
- Drilling machine, drill bit (Ø6 mm and Ø7 mm)
- Jigsaw and circular saw
- File/deburring tool
- Screwdriver
- (Torx, cross and slot)
- Rubber mallet
- Ring and open-end spanner (size 17 mm)



Parts list crossbeam

Screw type

- UKST M4x10 (ISO 14581)



Levelling heights

- 60 – 80 mm
- 75 – 105 mm
- 100 – 155 mm
- 150 – 255 mm

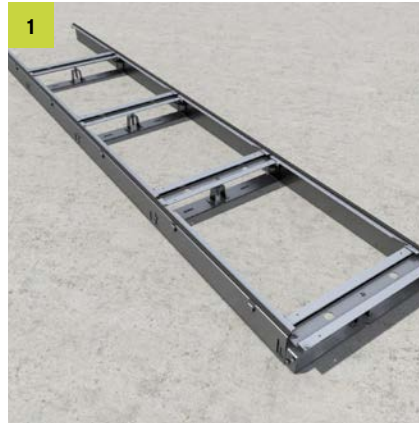

1
Screed-flush duct system UBSF consists of the base body with four levelling brackets, centre supports, four screwed crossbeams and one loose crossbeam including screws.

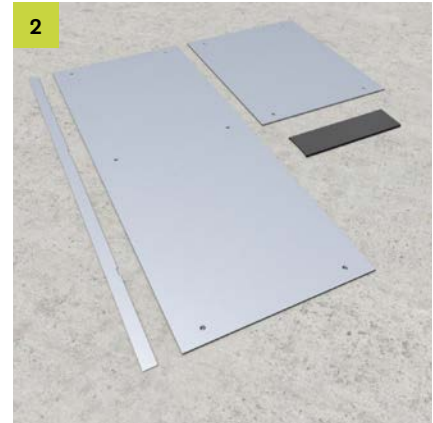

2
Accessories for the screed-flush duct system:

- 2x cover UBSFD (1 metre each)
- 4x adjusting strips UBSFPT
- 4x impact sound profile UBSFPTS

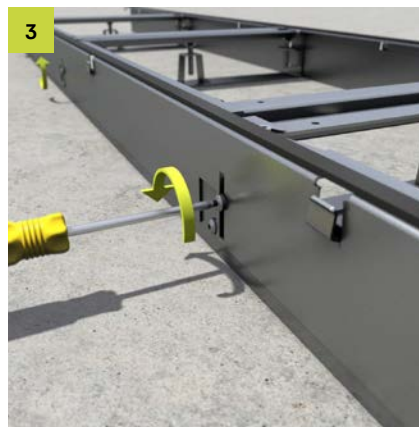

3
All upper screws must be loosened slightly on both duct walls. When delivered, these are tightened and provide stability during transport.

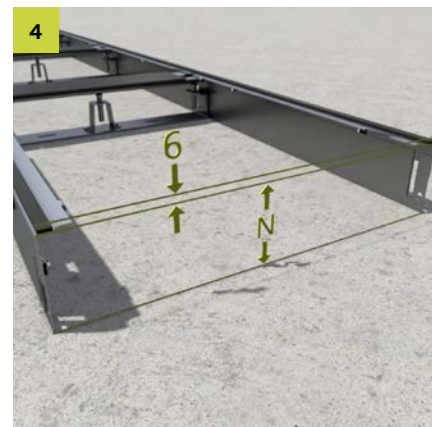

4
When setting the duct according to the metre tear, the thickness of the cover and the rubber seal (6 mm in total) must be taken into account. Screed height minus 6 mm.

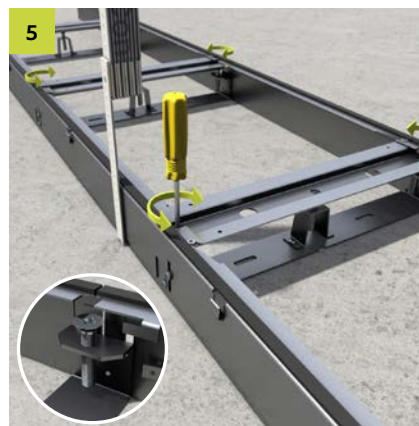

5
Adjust the height of the duct system using the M10 levelling screws, observing Fig. 4. Screed height according to the metre tear. The duct system may not be loaded.

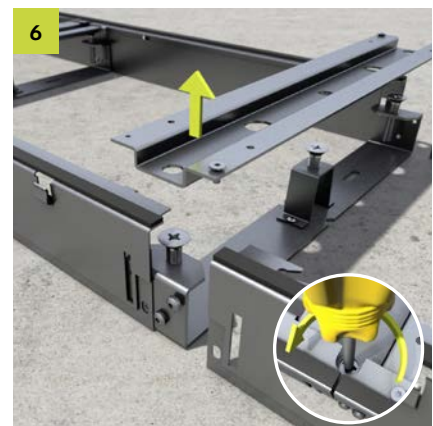

6
Loosen the M4 screws to remove the pre-assembled crossbeam. Place ducts next to each other. Connect them to each other using the levelling bracket.

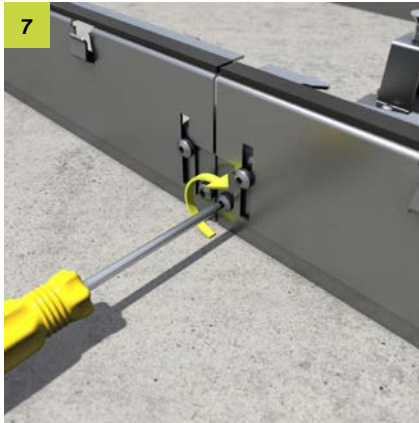

Tighten the lower screws on both sides. These are used to make the firm connection between the side wall and the levelling bracket.

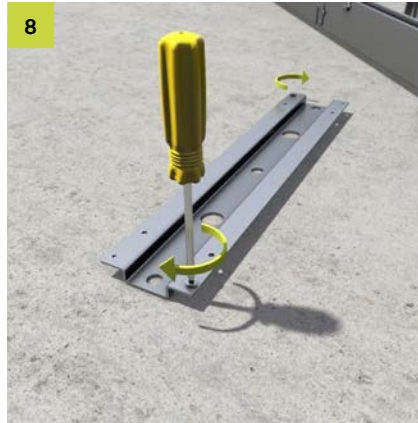

Complete the loosened crossbeam using M4 screws and reinsert.

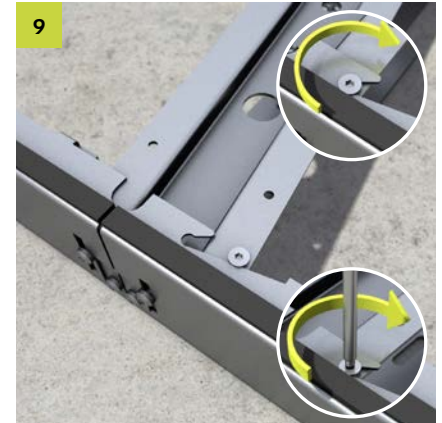

To insert the crossbeam into the duct, the screws must be pushed into the mould opening. Secure both components via the upper screws against loosening.

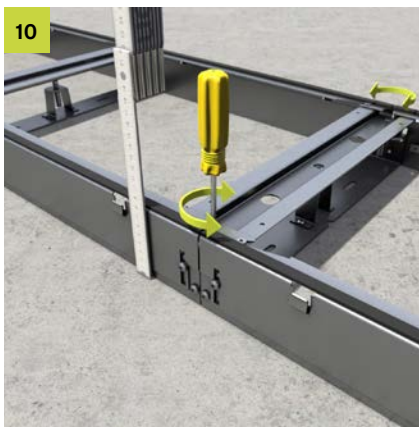

Re-levelling the duct system to screed height on both sides and via the centre support using a laser or digital hose scale.

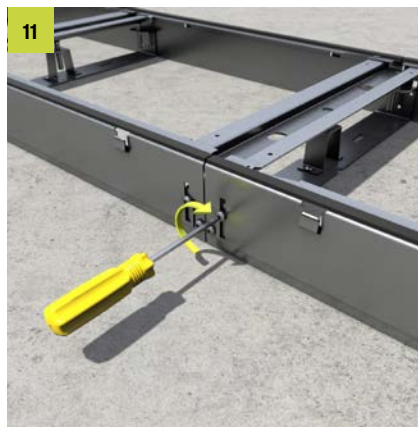

The base body and side walls are connected to each other by the upper screws on the duct wall. This fixes the set levelling height.

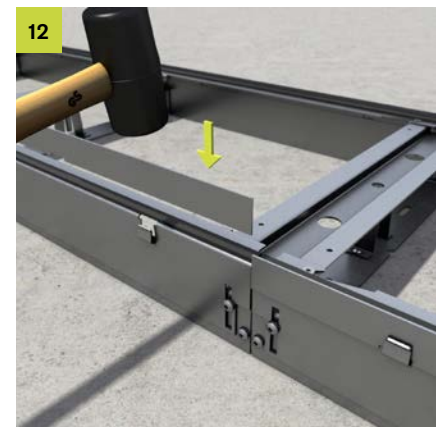

The adjusting strip can be inserted with the help of a rubber mallet.



The impact sound profile is clamped centrally on the crossbeam. The drill holes for fixing the covers may not be covered.

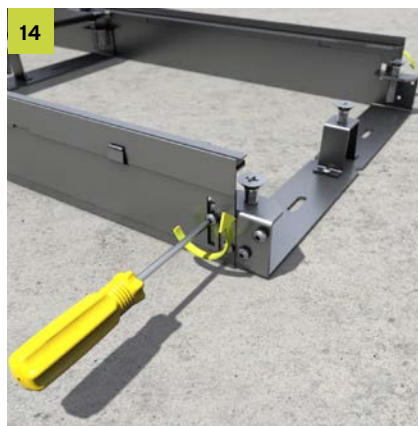

To mount the end piece, the levelling bracket and the associated screws must be removed.

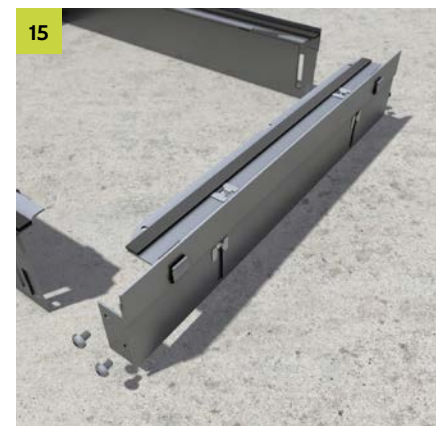

End piece is pre-assembled. The end piece is supplied with a top part, a bottom part, two spring clamp fasteners and two screws.



When the duct has been cut and the end piece is to be set, the bottom part of the end plate must be used to correctly position the connection holes ($\varnothing 7$ mm).



The end piece is fixed to the bottom of the duct on both sides using the side fixing screws.

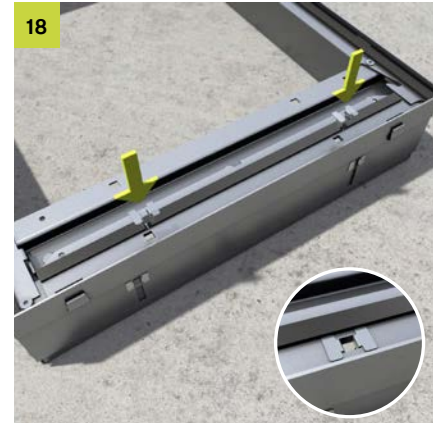

For stabilisation, a crossbeam is inserted and fastened to the end piece from above by two spring clamp fasteners. Screw in the M10 levelling bolts supplied before fixing the crossbeam.

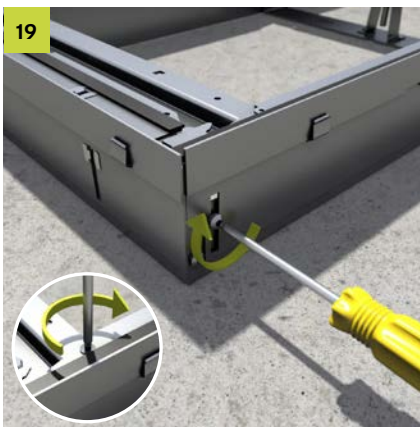

All screws on the duct side and the crossbeam must be tightened. Adjusting strips must be ordered separately.

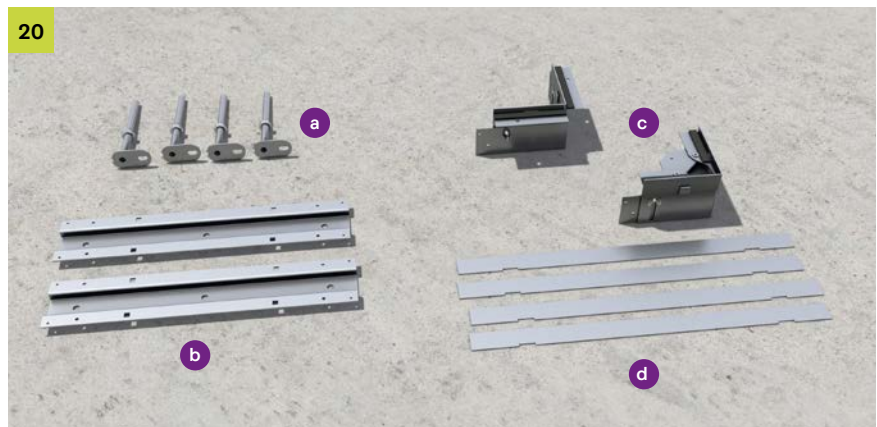

Scope of delivery for the moulded part "corner":

- a 2/4x UBDSLFL (levelling base)
- b 2x UBDFQT (crossbeam with thread)

c 1x UBDFMAB (mounting kit 90° bend)

Cover and adjusting strips (d) must be ordered separately.

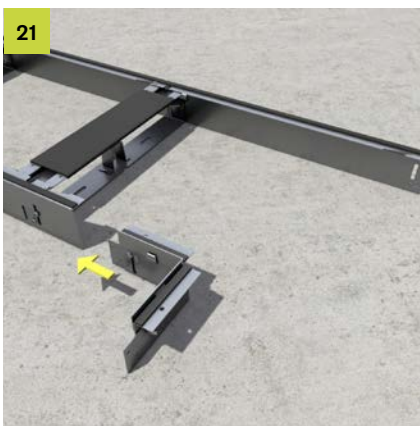

After shortening the duct side, screw the UBDFMAB mounting kit in place using holes and screws. If necessary, use a separately available template to mark the drill holes.

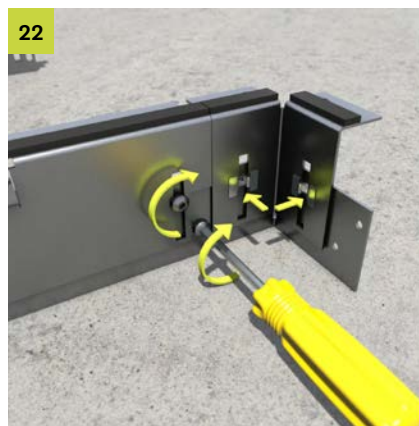

Bend the bottom part of the inner corner at the perforation to form a 90° angle. Then connect the top part and the bottom part of the inner corner using fastening clamps and screw them to the side wall.



Screw the upper and bottom part of the outside corner to the side wall of the duct.

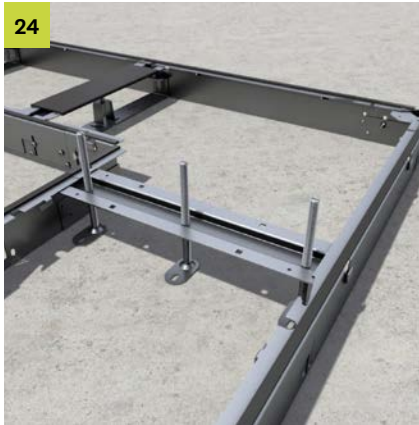

24 Complete the crossbeam with levelling base and then insert the crossbeam into the duct and level it to the correct height.



25 Secure levelling bases against loosening using lock nuts and shorten to the level of the crossbeam surface using a suitable tool.



26 Align the blind cover on the duct and secure it from above using screws.



27 Template is required if the trunking has been shortened. Place the cut duct at the end of the uncut duct and level it to the same height. Place the template over the screws on both sides and drill holes (\varnothing 6 mm) opposite the screw heads. Screw the cut duct to the levelling support.



28 The missing fixing holes for the crossbeam must be re-drilled with a diameter of 6 mm in the cut duct section. The crossbeam can be used as a drilling template for this. A crossbeam must always be placed between two duct sections.

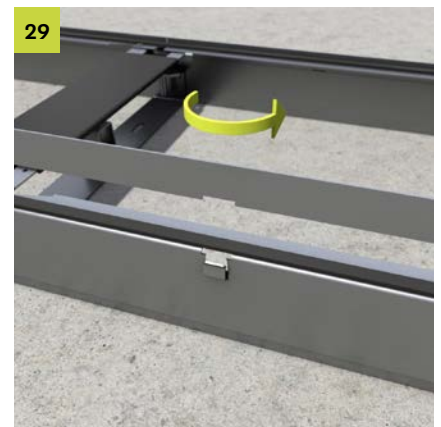

29 The adjusting strip can be set to 0 mm or 3 mm level. At 0 mm level, the notches in the adjusting strip are set flush with the side wall brackets. At 3 mm level, the notches are positioned next to the brackets. To do this, turn the adjusting strip horizontally by 180°.

All rights reserved. This document may not be reprinted or electronically reproduced without our prior written permission. The contents are subject to change without notice. Errors and omissions excepted. The publisher assumes no liability for any reason whatsoever. This document supersedes all previous documentation.

© PohlCon | PC-LIT-MA-UBSF-EN | 07-2024 | 1. | 07-2024

PohlCon GmbH

Nobelstr. 51
12057 Berlin
Germany

T +49 30 68283-04
F +49 30 68283-383

www.pohlcon.com