



Support systems

Brackets	F03-F10
Ceiling fixed suspensions	F11-F13
KSL-system	F14-F16
KHU-system	F17-F37
KHI-system	F38-F46
KHA-system	F47-F55
Profile rails	F56-F68



Numeric index

Support systems

A

A 2 C-rail, not perforated, 50x31 mm [F56](#)
A 4 C-rail, not perforated, 48x26 mm [F57](#)
A 41 C-rail, not perforated, 41x41 mm [F62](#)
A 7 C-rail, not perforated, 40x22 mm [F58](#)
A 8 C-rail, not perforated, 40x22 mm [F60](#)
A 9 C-rail, not perforated, 40x25 mm [F61](#)
AKL rail clamp [F51](#)
ASK 4 coupler for KHA-profile [F56](#)
ASK 8 coupler for KHA-profile [F56](#)
AV coupler for KHA-profile [F51](#)
AVA corner connector T-piece [F53](#)
AVAW corner connector left / center / right [F54](#)
AVB rail coupler U support [F53](#)
AVE corner connector 90° [F52](#)
AVL fastening strip [F52](#)
AVLW corner connector 90° [F54](#)

B

B 3 profile rail, not perforated, 28x12 mm [F65](#)
B 6 profile rail, not perforated, 28x15 mm [F66](#)
B 7 profile rail, not perforated, 30x15 mm [F66](#)
BGA 41 Mounting/ floor/ ceiling plate [F50](#)
BGA 41/2 head plate, profile 41 [F50](#)
BGI head plate, profile I80 [F41](#)
BGID head plate, profile I80 [F43](#)
BGIQ head plate, profile I80 [F42](#)
BGU 40 head plate, profile U40 [F28](#)
BGU 57 head plate, profile U57 [F28](#)
BGU 60 head plate, profile U60 [F29](#)
BGU 80 head plate, profile U80 [F30](#)
BGUD head plate, profile U40/ U57/ U60 [F31](#)
BGUDW head plate, profile U40/ U57/ U60 [F31](#)
BGUQ head plate, profile U50 [F30](#)
BL 3 corner angle [F44](#)
BL 4 corner angle, profile U50/ U60/ U100 [F35](#)
BL 5 corner angle [F51](#)
BL 7 corner angle [F45](#)
BL 8 corner angle [F45](#)
BLD adaptor diagonal [F36](#)
BLI corner angle [F45](#)

D

DB ceiling fixed bracket [F11](#)
DKSL ceiling fixed bracket, light duty [F15](#)

G

GBAG central hanger [F12](#)
GBAR central hanger [F11](#)

H

HKI support connector [F43](#)
HKIQ support connector [F44](#)
HKIW support connector [F44](#)

K

KA 30 bracket, light duty, profile 41 [F49](#)
KA 41 bracket, standard, profile 41 [F49](#)
KB junction plate [F36](#)
KDAG 41 ceiling fixed bracket, profile 41 [F47](#)
KDI bracket support, heavy, profile I80 [F38](#)
KDU 40 bracket support, 40x30mm [F17](#)
KDU 57 bracket support, 57x30mm [F19](#)
KDU 60 bracket support, heavy, 60x40 mm [F21](#)
KHA 2 C-rail, perforated, 50x31 mm [F57](#)
KHA 21 C-rail, perforated, 41x21 mm [F62](#)
KHA 4 C-rail, perforated, 48x26 mm [F58](#)
KHA 41 C-rail, perforated, 41x41 mm [F48](#), [F63](#)
KHA 42 C-rail, perforated, 41x42 mm [F65](#)

KHA 7 C-rail, perforated, 40x22 mm [F59](#)
KHA 8 C-rail, perforated, 40x22 mm [F60](#)
KHA 82 C-rail, perforated, 41x82 mm [F64](#)
KHA 9 C-rail, perforated, 40x25 mm [F61](#)
KHAL 41 C-rail, perforated, 41x41 mm [F64](#)
KHB 7 profile rail, perforated, 30x15 mm [F67](#)
KHI bracket support, type KT [F39](#)
KHU 40 bracket support, 40x30mm [F22](#)
KHU 57 bracket support, 57x30mm [F24](#)
KHU 60 bracket support, profile U60 [F26](#)
KHU 80 bracket support, profile U80 [F27](#)
KHUSS 40 support piece [F33](#)
KHUSS 57 support piece [F34](#)
KHUSS 60 support piece [F35](#)
KHUV 40 coupler [F32](#)
KHUV 57 coupler [F32](#)
KHUV 60 coupler, profile U60 [F33](#)
KIS bracket, heavy [F09](#)
KISS bracket, very heavy [F10](#)
KSL bracket, light duty [F14](#)
KSL-SP spacer [F16](#)
KSLW bracket, light and ceiling stem [F03](#), [F14](#)
KT bracket, standard, profile I80 [F40](#)
KTS bracket, heavy, profile I80 [F40](#)
KTSS bracket, very heavy, profile I80 [F41](#)
KW bracket, standard [F05](#)
KWF bracket, light duty [F05](#)
KWLL bracket, light duty [F03](#)
KWMS wall bracket, medium duty [F06](#)
KWS bracket, heavy [F07](#)
KWSS bracket, very heavy [F08](#)
KWW wall bracket [F04](#)
KZF cold zinc paint [F37](#), [F46](#)
KZS cold zinc spray [F37](#), [F46](#)

L

LGL elongated hole [F68](#)

M

MA 60 central hanger [F12](#)

P

PRS cut [F67](#)

R

RL round hole [F67](#)

S

SA 1 protection end cap [F54](#)
SA 2 protection end cap [F55](#)
SAI 21 protection end cap [F55](#)
SAI 41 protection end cap [F55](#)
SI protection end cap, yellow [F46](#)
SU 40 protection end cap [F37](#)
SU 57 protection end cap [F37](#)
SU 60 protection end cap, profile U60 [F37](#)

Support systems

Brackets

KWLL bracket, light duty

F_D/P : coefficient for calculation of the dowel load F_D with effective bracket load P respectively the sum of effective bracket loads. This article is also available made in stainless steel finish, material No. 1.4571 / 1.4404 (V4A).
For assembly instructions, see the chapter assembly.



article number	H mm	B mm	L mm	P_{max} kN	F_D/P	G kg
S						
KWLL 010S	15	100	110	0,3	2,0	0,13
KWLL 020S	15	200	210	0,3	3,0	0,20
KWLL 030S	15	300	310	0,3	4,0	0,28
E						
KWLL 010E	15	100	110	0,3	2,0	0,13
KWLL 020E	15	200	210	0,3	3,0	0,20
KWLL 030E	15	300	310	0,3	4,0	0,28

accessories optional:

SD expansion anchor (page G12)
KLR fixing set (page G33)

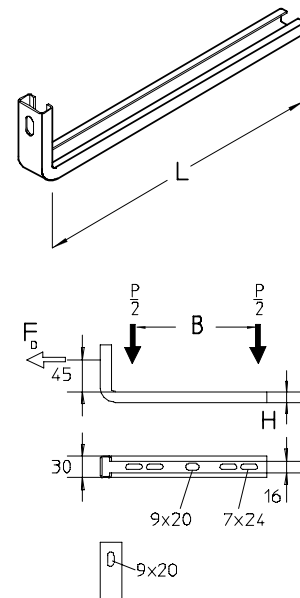

KSLW bracket, light and ceiling stem

F_D/P : coefficient for calculation of the dowel load F_D with effective bracket load P respectively the sum of effective bracket loads.
For an application example, see the chapter assembly.
For assembly instructions, see the chapter assembly.



article number	H mm	B mm	L mm	G kg
S				
KSLW 010S	20	100	120	0,36
KSLW 020S	20	200	220	0,53
KSLW 030S	20	300	320	0,69
KSLW 040S	20	400	420	0,86
KSLW 050S	20	500	520	1,03
KSLW 060S	20	600	620	1,18

accessories included:

1 x **KSL-SP S** spacer (page F16)

article number	H mm	B mm	L mm	G kg
S				
KSLW 015S	20	150	170	0,45
KSLW 025S	20	250	270	0,61

accessories included:

1 x **KSL-SP F** spacer (page F16)

accessories optional:

SD expansion anchor (page G12)

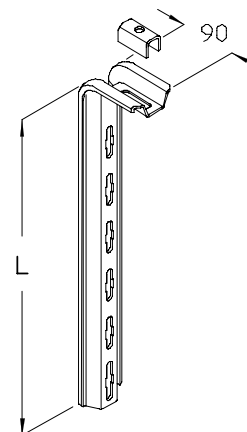

Support systems

Brackets

KSLW bracket, light and ceiling stem

F_D/P : coefficient for calculation of the dowel load F_D with effective bracket load P respectively the sum of effective bracket loads.

For an application example, see the chapter assembly.

For assembly instructions, see the chapter assembly.

article number	H mm	B mm	L mm	G kg
F				
KSLW 010F	20	100	120	0,38
KSLW 015F	20	150	170	0,47
KSLW 020F	20	200	220	0,56
KSLW 025F	20	250	270	0,65
KSLW 030F	20	300	320	0,73
KSLW 040F	20	400	420	0,92
KSLW 050F	20	500	520	1,10
KSLW 060F	20	600	620	1,26

accessories included:

1 x **KSL-SP F** spacer (page F16)

accessories optional:

SD expansion anchor (page G12)

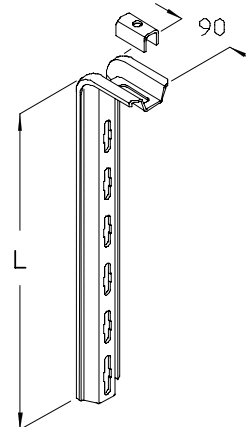

KWW wall bracket

For an application example, see the chapter assembly.

For assembly instructions, see the chapter assembly.

article number	B mm	L mm	G kg
F			
KWW 020F	100	200	0,27
KWW 030F	200	300	0,40
KWW 040F	300	400	0,52
KWW 050F	400	500	0,65
KWW 060F	500	600	0,78
KWW 070F	600	700	0,91

accessories optional:

SD expansion anchor (page G12)

KLU fixing set (page G07)

KLR fixing set (page G33)

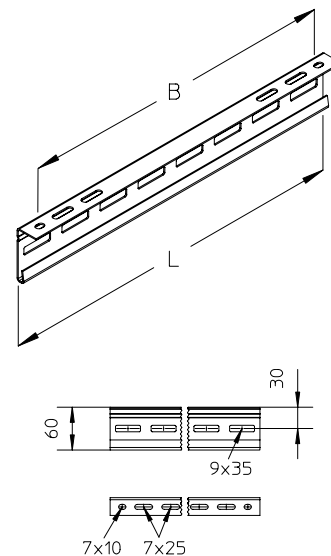

Support systems

Brackets

KWF bracket, light duty

F_D/P : coefficient for calculation of the dowel load F_D with effective bracket load P respectively the sum of effective bracket loads.

For assembly instructions, see the chapter assembly.

article number	H mm	B mm	L mm	P_{max} kN	F_D/P	G kg
S						
KWF 010S	80	100	120	1,2	1,58	0,23
KWF 020S	80	200	220	1,2	2,33	0,30
KWF 030S	80	300	320	1,2	3,15	0,45
KWF 040S	80	400	420	1,2	3,99	0,51

accessories included:

1 x **US 10x30** square washer, DIN 9021 (page G40)

accessories optional:

KDU 57 bracket support, 57x30mm (page F19)
KHU 57 bracket support, 57x30mm (page F24)
KDU 40 bracket support, 40x30mm (page F17)
KHU 40 bracket support, 40x30mm (page F22)

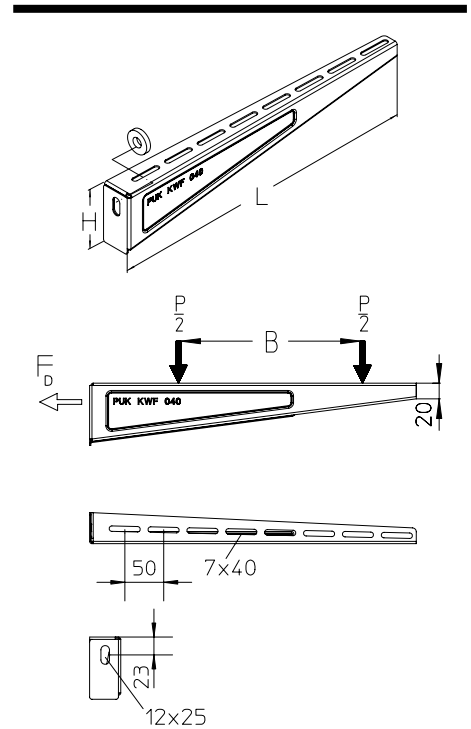

KW bracket, standard

F_D/P : coefficient for calculation of the dowel load F_D with effective bracket load P respectively the sum of effective bracket loads. This article is also available made in stainless steel finish, material No. 1.4571 / 1.4404 (V4A).

For an application example, see the chapter assembly.

For assembly instructions, see the chapter assembly.

article number	H mm	B mm	L mm	P_{max} kN	F_D/P	G kg
F						
KW 010F	34	100	120	1,4	3,10	0,13
KW 015F	34	150	170	1,4	4,10	0,16
KW 020F	56	200	220	2,0	3,00	0,35
KW 030F	56	300	320	2,0	4,00	0,50
KW 040F	75	400	420	2,4	3,60	0,80
KW 050F	96	500	520	2,1	3,40	1,40
KW 060F	96	600	620	2,1	4,00	1,60
KW 070F	96	700	720	3,0	5,68	2,27

E						
KW 010E	34	100	120	1,5	3,10	0,13
KW 015E	34	150	170	1,5	4,10	0,16
KW 020E	56	200	220	1,5	3,00	0,39
KW 030E	56	300	320	1,5	4,00	0,47
KW 040E	75	400	420	2,2	3,60	0,76
KW 050E	95	500	520	2,2	3,40	1,20
KW 060E	95	600	620	2,2	4,00	1,40

accessories optional:

SD expansion anchor (page G12)
KDU 57 bracket support, 57x30mm (page F19)
KLU fixing set (page G07)
KLR fixing set (page G33)

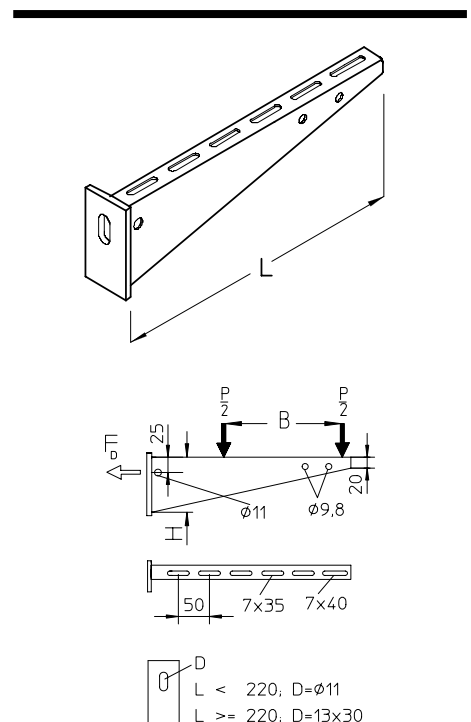

Support systems

Brackets

KWMS wall bracket, medium duty

F_D/P : coefficient for calculation of the dowel load F_D with effective bracket load P respectively the sum of effective bracket loads.

For an application example, see the chapter assembly.

article number	H mm	B mm	L mm	P_{max} kN	F_D/P	G kg
F						
KWMS 010F	85	100	120	3,8	1,36	0,53
KWMS 020F	85	200	220	3,8	1,81	0,76
KWMS 030F	85	300	320	3,8	2,32	0,99
KWMS 040F	85	400	420	3,8	2,86	1,21
KWMS 050F	85	400	420	3,8	3,42	1,43
KWMS 060F	85	600	620	3,8	3,99	1,65
KWMS 070F	85	700	720	2,9	5,68	1,88
E						
KWMS 010E	85	100	120	3,8	1,36	0,60
KWMS 020E	85	200	220	3,8	1,81	0,82
KWMS 030E	85	300	320	3,8	2,32	1,03
KWMS 040E	85	400	420	3,8	2,86	1,25
KWMS 050E	85	400	420	3,8	3,42	1,46
KWMS 060E	85	600	620	3,8	3,99	1,68
E4						
KWMS 010E4	85	100	120	3,8	1,36	0,60
KWMS 020E4	85	200	220	3,8	1,81	0,82
KWMS 030E4	85	300	320	3,8	2,32	1,03
KWMS 040E4	85	400	420	3,8	2,86	1,25
KWMS 050E4	85	400	420	3,8	3,42	1,46
KWMS 060E4	85	600	620	3,8	3,99	1,68

accessories optional:

KDU 57	bracket support, 57x30mm	(page F19)
KDU 60	bracket support, heavy, 60x40 mm	(page F21)
KHU 57	bracket support, 57x30mm	(page F24)
KHU 60	bracket support, profile U60	(page F26)
SD	expansion anchor	(page G12)
KLR	fixing set	(page G33)

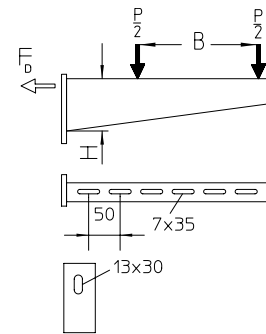
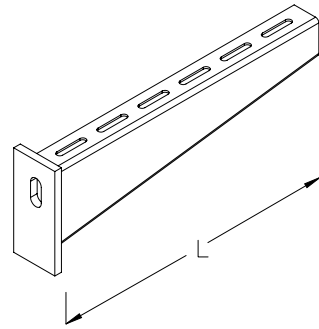

Support systems

Brackets

KWS bracket, heavy

F_D/P : coefficient for calculation of the dowel load F_D with effective bracket load P respectively the sum of effective bracket loads. This article is also available made in stainless steel finish, material No. 1.4571 / 1.4404 (V4A).

For an application example, see the chapter assembly.

For assembly instructions, see the chapter assembly.



article number	B mm	L mm	P_{max} kN	F_D/P	G kg
F					
KWS 020F	200	280	7,0	1,31	2,04
KWS 030F	300	380	6,7	1,49	2,40
KWS 040F	400	480	6,5	1,69	2,78
KWS 050F	500	580	6,3	1,91	3,32
KWS 060F	600	680	6,1	2,13	3,68
KWS 070F	600	780	5,2	2,60	4,04
KWS 080F	600	880	4,4	3,07	4,41
KWS 090F	600	980	3,6	3,56	4,77
KWS 100F	600	1080	2,8	4,06	5,14

accessories optional:

SD	expansion anchor	(page G12)
KDU 57	bracket support, 57x30mm	(page F19)
KLU	fixing set	(page G07)
WPHS-K	flange mounting clamp (brackets)	(page D21)

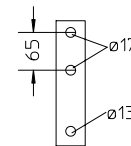
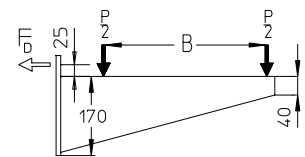
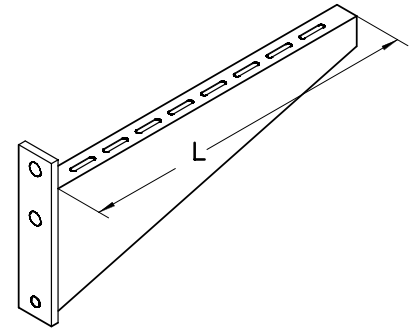

F

Support systems

Brackets

KWSS bracket, very heavy

F_D/P : coefficient for calculation of the dowel load F_D with effective bracket load P respectively the sum of effective bracket loads.

For an application example, see the chapter assembly.

For assembly instructions, see the chapter assembly.



article number	H mm	B mm	L mm	P_{max} kN	F_D/P	G kg
F						
KWSS 020F	166	200	280	10	0,76	2,59
KWSS 030F	196	300	380	10	0,86	3,37
KWSS 040F	236	400	480	10	0,91	4,18
KWSS 050F	266	500	580	10	0,97	4,96
KWSS 060F	236	600	680	10	1,26	5,51
KWSS 070F	266	600	780	10	1,44	6,28
KWSS 080F	301	600	880	10	1,56	7,08
KWSS 090F	331	600	980	10	1,66	7,85
KWSS 100F	366	600	1080	10	1,72	8,65

accessories optional:

- SD** expansion anchor (page G12)
- WPHS-A** flange mounting clamp (C-profiles) (page D22)
- VAB-HB** shear connector rod, concrete (page G14)
- VAS-AS** shear connector rod, stone (page G15)

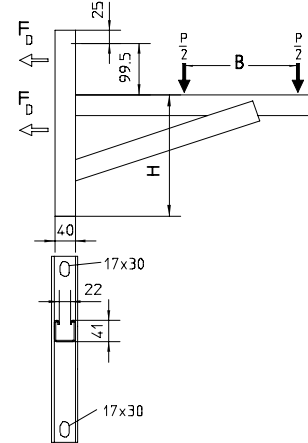
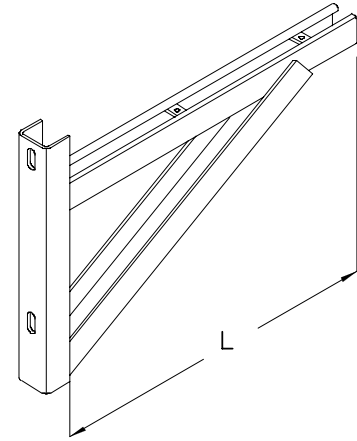

Support systems

Brackets

KIS bracket, heavy

F_D/P : coefficient for calculation of the dowel load F_D with effective bracket load P respectively the sum of effective bracket loads.

For assembly instructions, see the chapter assembly.



article number	B mm	L mm	P_{max} kN	F_D/P	G kg
F					
KIS 020F	200	280	7,0	0,66	4,32
KIS 030F	300	380	6,7	0,76	4,65
KIS 040F	400	480	6,5	0,86	5,00
KIS 050F	500	580	6,3	0,97	5,34
KIS 060F	600	680	6,1	1,09	5,68
KIS 070F	600	780	5,2	1,33	6,02
KIS 080F	600	880	4,4	1,57	6,36
KIS 090F	600	980	3,6	1,83	6,70
KIS 100F	600	1080	2,8	2,08	7,04

accessories optional:

SKS H beam clamp set (page G03)

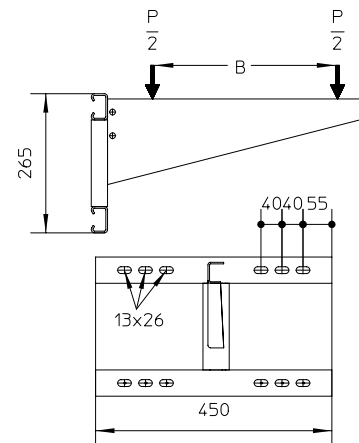
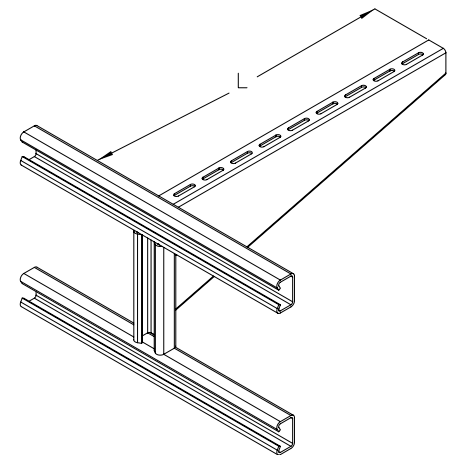

F

Support systems

Brackets

KISS bracket, very heavy

F_D/P : coefficient for calculation of the dowel load F_D with effective bracket load P respectively the sum of effective bracket loads.

For an application example, see the chapter assembly.

For assembly instructions, see the chapter assembly.



article number	H mm	B mm	L mm	P_{max} kN	F_D/P	G kg
F						
KISS 020F	150	200	280	10	0,93	4,66
KISS 030F	185	300	380	10	0,91	5,42
KISS 040F	215	400	480	10	0,92	6,17
KISS 050F	250	500	580	10	0,92	6,93
KISS 060F	280	600	680	10	0,92	7,70
KISS 070F	315	600	780	10	0,99	8,44
KISS 080F	345	600	880	10	1,06	9,21
KISS 090F	380	600	980	10	1,10	9,96
KISS 100F	410	600	1080	10	1,15	10,71

accessories optional:

WPHS-A flange mounting clamp (C-profiles) (page D22)

SKS M beam clamp set (page G05)

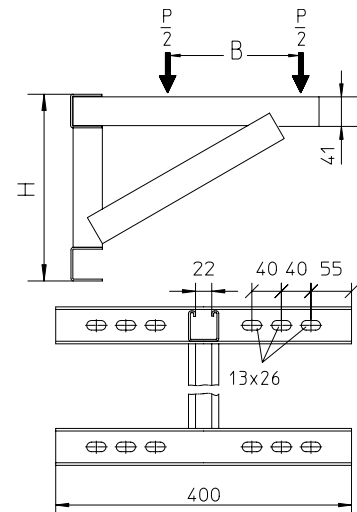
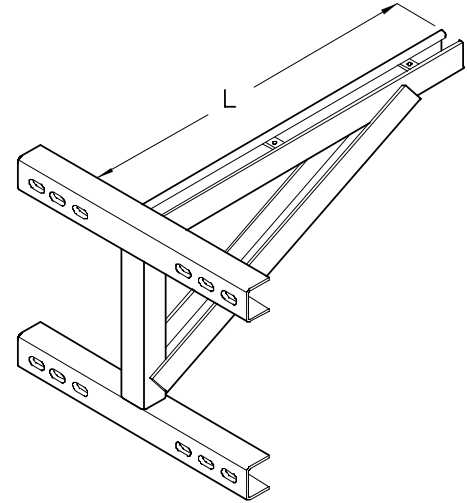

Support systems

Ceiling fixed suspensions

DB ceiling fixed bracket

F_D/P : coefficient for calculation of the dowel load F_D with effective bracket load P respectively the sum of effective bracket loads. This article is also available made in stainless steel finish, material No. 1.4571 / 1.4404 (V4A). For assembly instructions, see the chapter assembly.

article number	H mm	B mm	L mm	P_{max} kN	F_D/P	G kg
S						
DB 10S	170	100	110	0,60	1,2	0,25
DB 20S	170	200	210	0,40	1,1	0,36
DB 30S	170	300	310	0,28	1,1	0,47
E						
DB 10E	170	100	110	0,50	1,2	0,30
DB 20E	170	200	210	0,35	1,1	0,44
DB 30E	170	300	310	0,25	1,1	0,58

accessories optional:

KLR fixing set (page G33)
SAZ anchor (page G12)

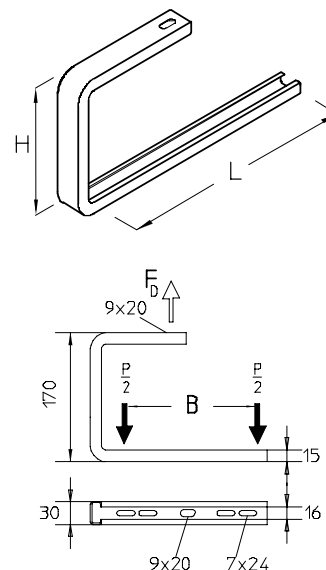

GBAR central hanger

F_D/P : coefficient for calculation of the dowel load F_D with effective bracket load P respectively the sum of effective bracket loads. For an application example, see the chapter assembly.

article number	B mm	L mm	P_{max} kN	F_D/P	G kg
S					
GBAR 10S	100	60	0,7	1	0,62
GBAR 20S	200	160	0,7	1	0,75
GBAR 30S	300	260	0,7	1	0,88

accessories included:

1 x **GB M10-10** threaded rod, DIN 976-1 (page G16)
 3 x **SEM 10** hexagon-nut, DIN 934 (page G41)
 1 x **US 10x30** square washer, DIN 9021 (page G40)
 1 x **KLR** fixing set (page G33)

article number	B mm	L mm	P_{max} kN	F_D/P	G kg
E					
GBAR 10E	100	60	0,7	1	0,62
GBAR 20E	200	160	0,7	1	0,75
GBAR 30E	300	260	0,7	1	0,88

accessories included:

1 x **GB M10-10E** threaded rod, DIN 976-1 (page G16)
 3 x **SEM 10E** hexagon-nut, DIN 934 (page G41)
 1 x **US 10x30E** square washer, DIN 9021 (page G40)
 1 x **KLR E** fixing set (page G33)

accessories optional:

SAZ anchor (page G12)

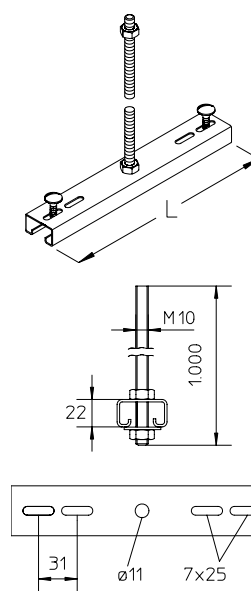

Support systems

Ceiling fixed suspensions

MA 60 central hanger

article number	H mm	B mm	L mm	G kg
S				
MA 60-10S	56	40	90	0,26
MA 60-20S	56	40	190	0,36
MA 60-30S	56	40	290	0,45

accessories optional:

KLR fixing set (page G33)

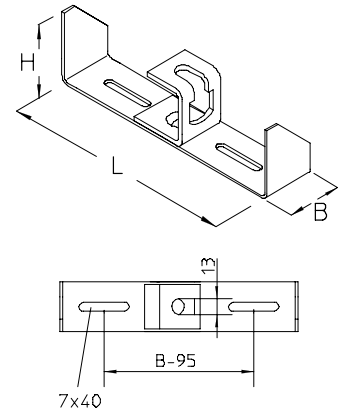

GBAG central hanger

F_D/P : coefficient for calculation of the dowel load F_D with effective bracket load P respectively the sum of effective bracket loads.
For an application example, see the chapter assembly.

article number	B mm	L mm	P_{max} kN	F_D/P	G kg
S					
GBAG 10S	100	41	0,5	1	0,42

accessories included:

- 1 x **GB M8-10** threaded rod, DIN 976-1 (page G16)
- 2 x **GV-L 30F** wire-mesh cable tray coupler (page A08)
- 1 x **US 8x17** square washer, DIN 125 (page G39)
- 3 x **SEM 8** hexagon-nut, DIN 934 (page G41)

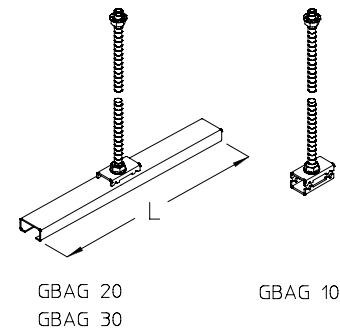

article number	B mm	L mm	P_{max} kN	F_D/P	G kg
S					
GBAG 20S	200	180	0,5	1	0,50

accessories included:

- 1 x **GB M8-10** threaded rod, DIN 976-1 (page G16)
- 1 x **GV-L 30F** wire-mesh cable tray coupler (page A08)
- 3 x **SEM 8** hexagon-nut, DIN 934 (page G41)
- 1 x **US 8x25** square washer, DIN 9021 (page G40)

article number	B mm	L mm	P_{max} kN	F_D/P	G kg
S					
GBAG 30S	300	280	0,5	1	0,57

accessories included:

- 1 x **GB M8-10** threaded rod, DIN 976-1 (page G16)
- 1 x **GV-L 30F** wire-mesh cable tray coupler (page A08)
- 1 x **US 8x25** square washer, DIN 9021 (page G40)
- 3 x **SEM 8** hexagon-nut, DIN 934 (page G41)

accessories optional:

SAZ anchor (page G12)

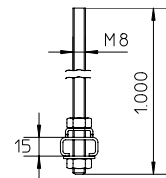

Support systems

Ceiling fixed suspensions

GBAG central hanger

F_D/P : coefficient for calculation of the dowel load F_D with effective bracket load P respectively the sum of effective bracket loads.

For an application example, see the chapter assembly.

article number	B mm	L mm	P_{max} kN	F_D/P	G kg
E					
GBAG 10E	100	41	0,5	1	0,42

accessories included:

1 x GB M8-10E	threaded rod, DIN 976-1	(page G16)
3 x SEM 8E	hexagon-nut, DIN 934	(page G41)
1 x US 8x17E	square washer, DIN 125	(page G40)
2 x GV-L 30E	wire-mesh cable tray coupler	(page A08)

article number	B mm	L mm	P_{max} kN	F_D/P	G kg
E					
GBAG 20E	200	180	0,5	1	0,50
GBAG 30E	300	280	0,5	1	0,57

accessories included:

1 x GB M8-10E	threaded rod, DIN 976-1	(page G16)
3 x SEM 8E	hexagon-nut, DIN 934	(page G41)
1 x US 8x25E	square washer, DIN 9021	(page G40)
1 x GV-L 30E	wire-mesh cable tray coupler	(page A08)

accessories optional:

SAZ	anchor	(page G12)
------------	--------	------------

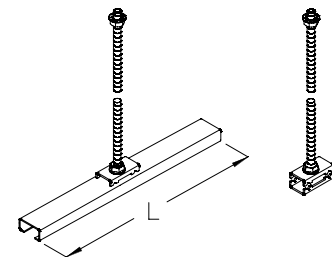

GBAG 20

GBAG 10

GBAG 30

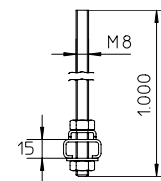

F

Support systems

KSL-system

KSL bracket, light duty

For an application example, see the chapter assembly.

article number	B mm	L mm	P _{max} kN	G kg
S				
KSL 010S	100	120	3,0	0,36
KSL 015S	150	170	2,4	0,45
KSL 020S	200	220	1,9	0,53
KSL 025S	250	270	1,5	0,61
KSL 030S	300	320	1,1	0,69
KSL 040S	400	420	0,8	0,86

accessories included:

1 x **FRS 8x20** round-head screw with square, DIN 603 (page G35)
 1 x **SEMS 8** hexagon nut, self-locking, DIN 6923 (page G41)

article number	B mm	L mm	P _{max} kN	G kg
F				
KSL 010F	100	120	3,0	0,38
KSL 015F	150	170	2,4	0,47
KSL 020F	200	220	1,9	0,56
KSL 025F	250	270	1,5	0,65
KSL 030F	300	320	1,1	0,73
KSL 040F	400	420	0,8	0,92

accessories included:

1 x **FRS 8x20E** round-head screw with square, DIN 603 (page G35)
 1 x **SEMS 8E** hexagon nut, self-locking, DIN 6923 (page G41)

accessories optional:

KLRL clamping assembly (page G36)

KSLW bracket, light and ceiling stem

F_d/P : coefficient for calculation of the dowel load F_d with effective bracket load P respectively the sum of effective bracket loads.

For an application example, see the chapter assembly.

For assembly instructions, see the chapter assembly.

article number	H mm	B mm	L mm	G kg
S				
KSLW 010S	20	100	120	0,36
KSLW 020S	20	200	220	0,53
KSLW 030S	20	300	320	0,69
KSLW 040S	20	400	420	0,86
KSLW 050S	20	500	520	1,03
KSLW 060S	20	600	620	1,18

accessories included:

1 x **KSL-SP S** spacer (page F16)

article number	H mm	B mm	L mm	G kg
S				
KSLW 015S	20	150	170	0,45
KSLW 025S	20	250	270	0,61

accessories included:

1 x **KSL-SP F** spacer (page F16)

accessories optional:

SD expansion anchor (page G12)

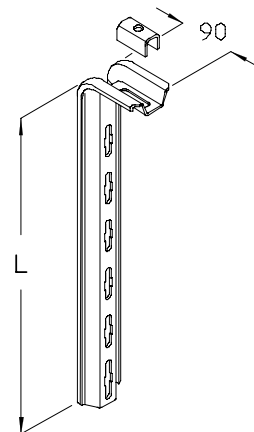
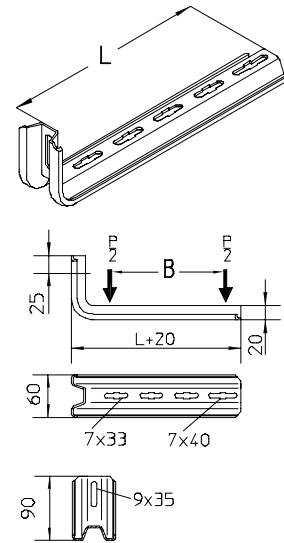

Support systems

KSL-system

KSLW bracket, light and ceiling stem

F_d/P : coefficient for calculation of the dowel load F_d with effective bracket load P respectively the sum of effective bracket loads.

For an application example, see the chapter assembly.

For assembly instructions, see the chapter assembly.

article number	H mm	B mm	L mm	G kg
F				
KSLW 010F	20	100	120	0,38
KSLW 015F	20	150	170	0,47
KSLW 020F	20	200	220	0,56
KSLW 025F	20	250	270	0,65
KSLW 030F	20	300	320	0,73
KSLW 040F	20	400	420	0,92
KSLW 050F	20	500	520	1,10
KSLW 060F	20	600	620	1,26

accessories included:

1 x **KSL-SP F** spacer (page F16)

accessories optional:

SD expansion anchor (page G12)

DKSL ceiling fixed bracket, light duty

F_d/P : coefficient for calculation of the dowel load F_d with effective bracket load P respectively the sum of effective bracket loads.

For an application example, see the chapter assembly.

article number	H mm	B mm	L mm	P_{max} kN	F_d/P	G kg
S						
DKSL 010S	170	100	120	0,9	3,1	0,59
DKSL 020S	170	200	220	0,5	2,1	0,76
DKSL 030S	170	300	320	0,4	2,7	0,91
DKSL 040S	170	400	420	0,3	3,3	1,08

F						
DKSL 010F	170	100	120	0,9	3,1	0,63
DKSL 020F	170	200	220	0,5	2,1	0,81
DKSL 030F	170	300	320	0,4	2,7	0,97
DKSL 040F	170	400	420	0,3	3,3	1,15

accessories included:

1 x **KSL-SP F** spacer (page F16)

accessories optional:

SD expansion anchor (page G12)

SAZ anchor (page G12)

KLRL clamping assembly (page G36)

KLU fixing set (page G07)

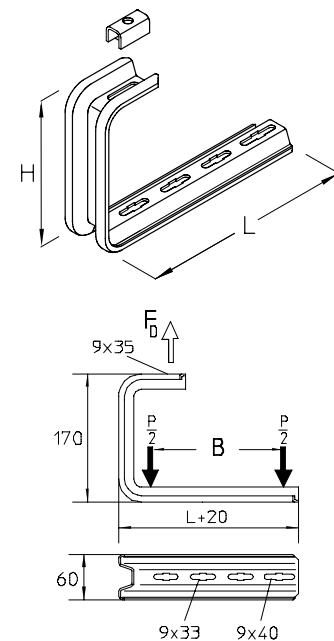
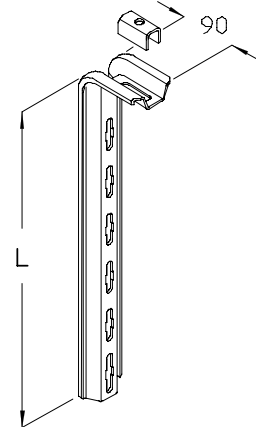

Support systems

KSL-system

KSL-SP spacer

For an application example, see the chapter assembly.

article number	H mm	B mm	G kg
S			
KSL-SP S	35	18	0,28
F			
KSL-SP F	35	18	0,03

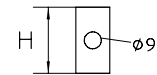
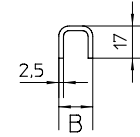
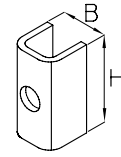

Support systems

KHU-system

KDU 40 bracket support, 40x30mm

Ceiling bracket support, U-profile 40 x 30mm, continuously three-way perforated, with welded head plate, certified according to DIN EN 61537.

Load figures P_{max} when using a support piece with the hot-dip galvanized Bracket support according to DIN EN 61537 (test No. 10.8.2.3). It is recommended to apply the support piece from a bracket width of 400mm or if the bracket is installed at the end of the ceiling fixed bracket.

For assembly instructions, see the chapter assembly.

article number	L mm	G kg
F		
KDU 40-02F	200	0,38
KDU 40-03F	300	0,50
KDU 40-04F	400	0,62
KDU 40-05F	500	0,73
KDU 40-06F	600	0,86
KDU 40-07F	700	0,98
KDU 40-08F	800	1,10
KDU 40-09F	900	1,22
KDU 40-10F	1000	1,34
KDU 40-11F	1100	1,46
KDU 40-12F	1200	1,58
KDU 40-13F	1300	1,70
KDU 40-14F	1400	1,82
KDU 40-15F	1500	1,94

E		
KDU 40-02E	200	0,36
KDU 40-03E	300	0,47
KDU 40-04E	400	0,60
KDU 40-05E	500	0,70
KDU 40-06E	600	0,81
KDU 40-07E	700	0,92
KDU 40-08E	800	1,03
KDU 40-09E	900	1,15
KDU 40-10E	1000	1,26
KDU 40-11E	1100	1,40
KDU 40-12E	1200	1,50
KDU 40-13E	1300	1,60
KDU 40-14E	1400	1,73
KDU 40-15E	1500	1,83

accessories optional:

KWF	bracket, light duty	(page F05)
KW	bracket, standard	(page F05)
KHU 40	bracket support, 40x30mm	(page F22)
KHUV 40	coupler	(page F32)
KHUSS 40	support piece	(page F33)
SU 40	protection end cap	(page F37)

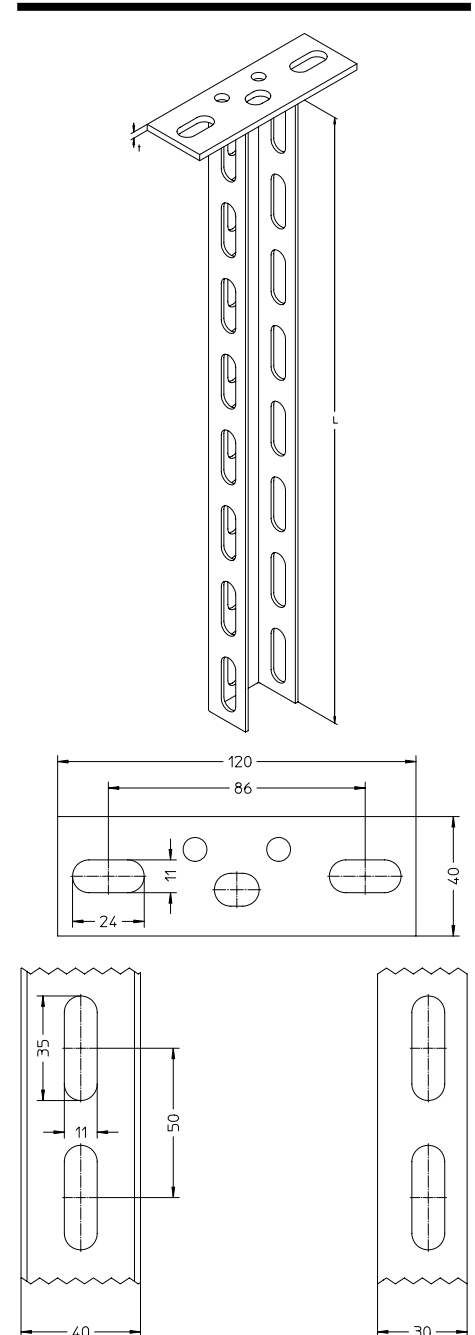

Support systems

KHU-system

KDU 40 bracket support, 40x30mm

Ceiling bracket support, U-profile 40 x 30mm, continuously three-way perforated, with welded head plate, certified according to DIN EN 61537.

Load figures P_{max} when using a support piece with the hot-dip galvanized Bracket support according to DIN EN 61537 (test No. 10.8.2.3). It is recommended to apply the support piece from a bracket width of 400mm or if the bracket is installed at the end of the ceiling fixed bracket.

For assembly instructions, see the chapter assembly.

article number	L mm	G kg
E4		
KDU 40-02E4	200	0,36
KDU 40-03E4	300	0,47
KDU 40-04E4	400	0,60
KDU 40-05E4	500	0,70
KDU 40-06E4	600	0,81
KDU 40-07E4	700	0,92
KDU 40-08E4	800	1,03
KDU 40-09E4	900	1,16
KDU 40-10E4	1000	1,26
KDU 40-11E4	1100	1,40
KDU 40-12E4	1200	1,50
KDU 40-13E4	1300	1,61
KDU 40-14E4	1400	1,73
KDU 40-15E4	1500	1,84

accessories optional:

KWF	bracket, light duty	(page F05)
KW	bracket, standard	(page F05)
KHU 40	bracket support, 40x30mm	(page F22)
KHUV 40	coupler	(page F32)
KHUSS 40	support piece	(page F33)
SU 40	protection end cap	(page F37)

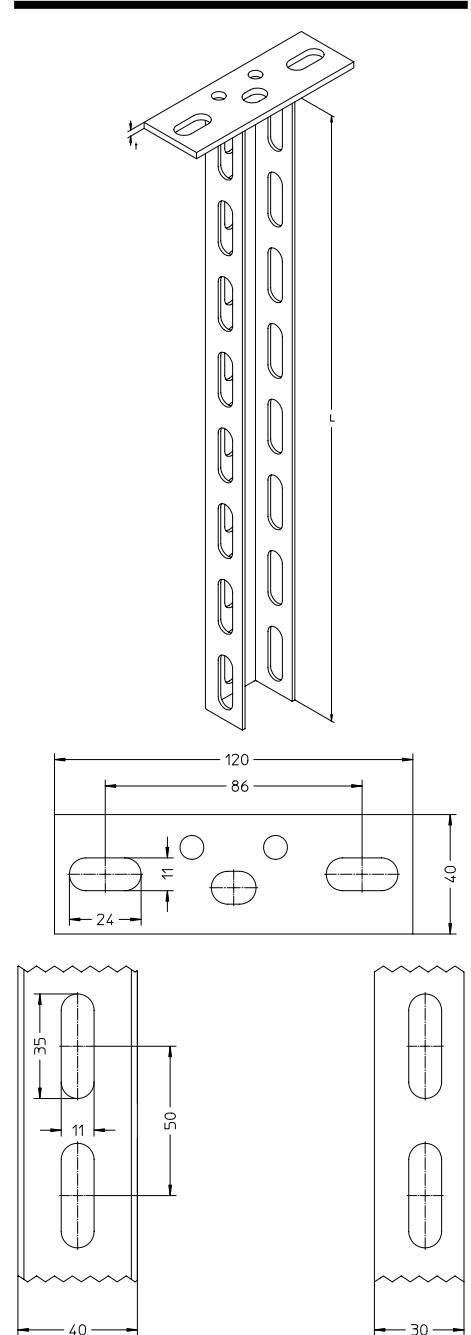

Support systems

KHU-system

KDU 57 bracket support, 57x30mm

Ceiling bracket support, U-profile 57 x 30mm, continuously three-way perforated, with welded head plate, certified according to DIN EN 61537.

Load figures P_{max} when using a support piece with the hot-dip galvanized Bracket support according to DIN EN 61537 (test No. 10.8.2.3). It is recommended to apply the support piece from a bracket width of 400mm or if the bracket is installed at the end of the ceiling fixed bracket. For the system-tested circuit integrity maintenance the support piece KHUSS 60 must be used.

For assembly instructions, see the chapter assembly.

article number	L mm	G kg
F		
KDU 57-02F	200	0,59
KDU 57-03F	300	0,77
KDU 57-04F	400	0,95
KDU 57-05F	500	1,13
KDU 57-06F	600	1,31
KDU 57-07F	700	1,49
KDU 57-08F	800	1,68
KDU 57-09F	900	1,86
KDU 57-10F	1000	2,04
KDU 57-11F	1100	2,22
KDU 57-12F	1200	2,40
KDU 57-13F	1300	2,58
KDU 57-14F	1400	2,77
KDU 57-15F	1500	2,95
E		
KDU 57-02E	200	0,57
KDU 57-03E	300	0,74
KDU 57-04E	400	0,91
KDU 57-05E	500	1,08
KDU 57-06E	600	1,25
KDU 57-07E	700	1,42
KDU 57-08E	800	1,59
KDU 57-09E	900	1,76
KDU 57-10E	1000	1,93
KDU 57-11E	1100	2,10
KDU 57-12E	1200	2,27
KDU 57-13E	1300	2,44
KDU 57-14E	1400	2,61
KDU 57-15E	1500	2,78

accessories optional:

KWF	bracket, light duty	(page F05)
KW	bracket, standard	(page F05)
KWMS	wall bracket, medium duty	(page F06)
KHU 57	bracket support, 57x30mm	(page F24)
KHUV 57	coupler	(page F32)
KHUSS 57	support piece	(page F34)
KHUSS 60	support piece	(page F35)
SU 57	protection end cap	(page F37)

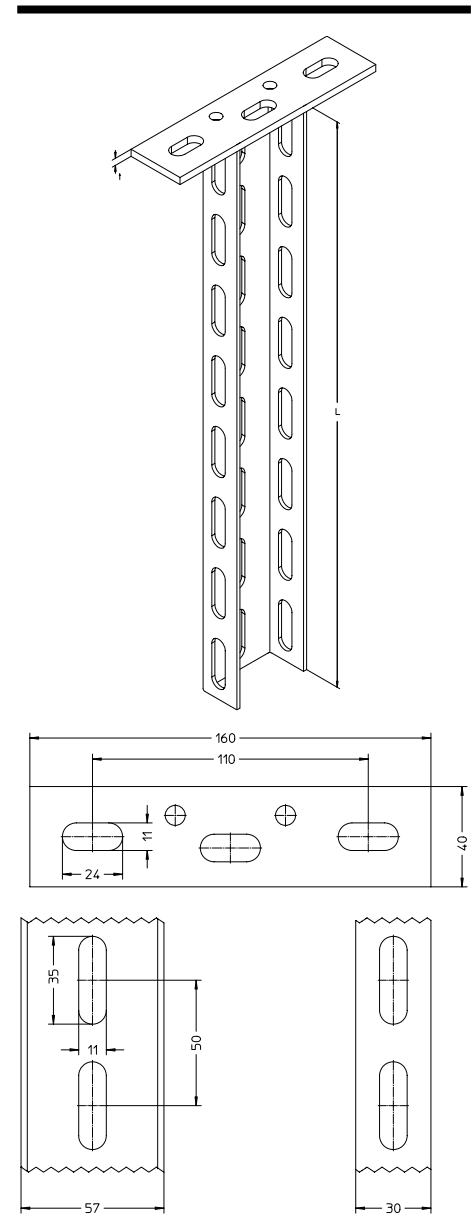

Support systems

KHU-system

KDU 57 bracket support, 57x30mm

Ceiling bracket support, U-profile 57 x 30mm, continuously three-way perforated, with welded head plate, certified according to DIN EN 61537.

Load figures P_{max} when using a support piece with the hot-dip galvanized Bracket support according to DIN EN 61537 (test No. 10.8.2.3). It is recommended to apply the support piece from a bracket width of 400mm or if the bracket is installed at the end of the ceiling fixed bracket. For the system-tested circuit integrity maintenance the support piece KHUSS 60 must be used.

For assembly instructions, see the chapter assembly.

article number	L mm	G kg
E4		
KDU 57-02E4	200	0,57
KDU 57-03E4	300	0,74
KDU 57-04E4	400	0,91
KDU 57-05E4	500	1,08
KDU 57-06E4	600	1,25
KDU 57-07E4	700	1,42
KDU 57-08E4	800	1,59
KDU 57-09E4	900	1,76
KDU 57-10E4	1000	1,93
KDU 57-11E4	1100	2,10
KDU 57-12E4	1200	2,27
KDU 57-13E4	1300	2,44
KDU 57-14E4	1400	2,61
KDU 57-15E4	1500	2,78

accessories optional:

KWF	bracket, light duty	(page F05)
KW	bracket, standard	(page F05)
KWMS	wall bracket, medium duty	(page F06)
KHU 57	bracket support, 57x30mm	(page F24)
KHUV 57	coupler	(page F32)
KHUSS 57	support piece	(page F34)
KHUSS 60	support piece	(page F35)
SU 57	protection end cap	(page F37)

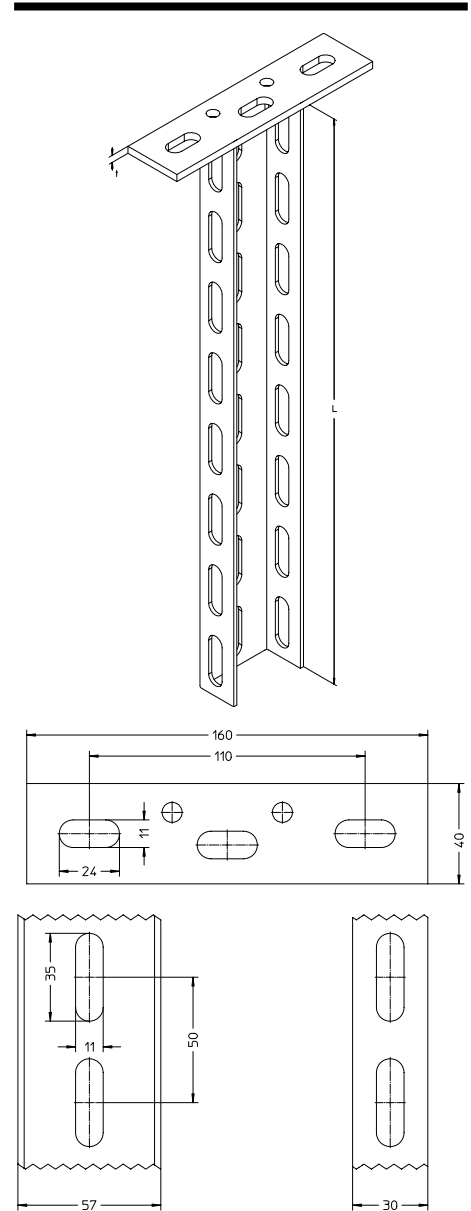

Support systems

KHU-system

KDU 60 bracket support, heavy, 60x40 mm

F_d/P : coefficient for calculation of the dowel load F_d with effective bracket load P respectively the sum of effective bracket loads. This article is also available made in stainless steel finish, material No. 1.4571 / 1.4404 (V4A).

For an application example, see the chapter assembly.

For assembly instructions, see the chapter assembly.



article number	L mm	t mm	G kg
F			
KDU 60-02F	200	6	1,40
KDU 60-03F	300	6	1,80
KDU 60-04F	400	6	2,10
KDU 60-05F	500	6	2,50
KDU 60-06F	600	6	2,80
KDU 60-07F	700	6	3,20
KDU 60-08F	800	6	3,50
KDU 60-09F	900	6	3,90
KDU 60-10F	1000	6	4,20
KDU 60-11F	1100	8	4,80
KDU 60-12F	1200	8	5,20
KDU 60-13F	1300	8	5,50
KDU 60-14F	1400	8	5,90
KDU 60-15F	1500	8	6,30
KDU 60-16F	1600	8	6,60
KDU 60-17F	1700	8	7,00
KDU 60-18F	1800	8	7,30
KDU 60-19F	1900	8	7,70
KDU 60-20F	2000	8	8,00
E			
KDU 60-02E	200	6	1,40
KDU 60-03E	300	6	1,80
KDU 60-04E	400	6	2,10
KDU 60-05E	500	6	2,50
KDU 60-06E	600	6	2,80
KDU 60-07E	700	6	3,20
KDU 60-08E	800	6	3,50
KDU 60-09E	900	6	3,90
KDU 60-10E	1000	6	4,20
KDU 60-11E	1100	6	4,80
KDU 60-12E	1200	6	5,20
KDU 60-13E	1300	6	5,50
KDU 60-14E	1400	6	5,90
KDU 60-15E	1500	6	6,30
KDU 60-16E	1600	6	6,60
KDU 60-17E	1700	6	7,00
KDU 60-18E	1800	6	7,30
KDU 60-19E	1900	6	7,70
KDU 60-20E	2000	6	8,00

accessories optional:

KW	bracket, standard	(page F05)
KWMS	wall bracket, medium duty	(page F06)
KWS	bracket, heavy	(page F07)
SD	expansion anchor	(page G12)
SU 60	protection end cap, profile U60	(page F37)

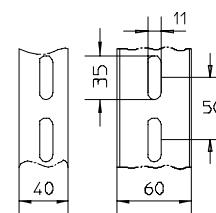
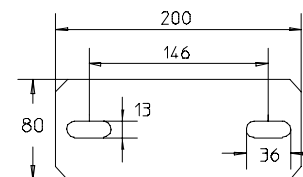
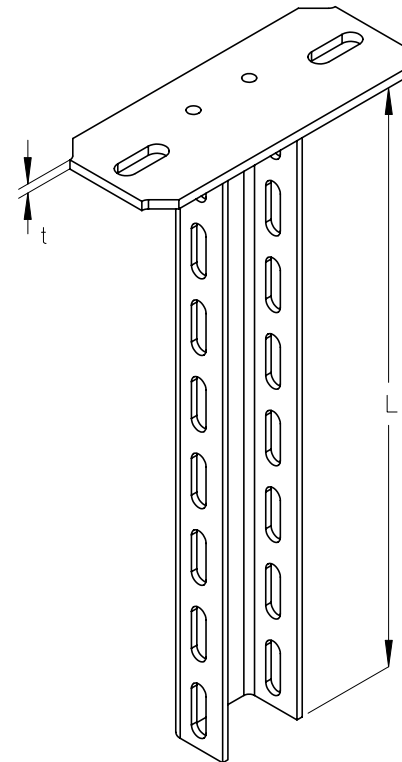

Support systems

KHU-system

KHU 40 bracket support, 40x30mm

Ceiling bracket support, U-profile 40 x 30mm, continuously three-way perforated.

It is recommended to apply the support piece from a bracket width of 400mm or if the bracket is installed at the end of the ceiling fixed bracket.

For assembly instructions, see the chapter assembly.

article number	L mm	G kg
S		
KHU 40-02S	200	0,22
KHU 40-03S	300	0,34
KHU 40-04S	400	0,45
KHU 40-05S	500	0,56
KHU 40-06S	600	0,67
KHU 40-07S	700	0,79
KHU 40-08S	800	0,90
KHU 40-09S	900	1,01
KHU 40-10S	1000	1,12
KHU 40-11S	1100	1,23
KHU 40-12S	1200	1,35
KHU 40-13S	1300	1,55
KHU 40-14S	1400	1,60
KHU 40-15S	1500	1,70
KHU 40-30S	3000	3,40
KHU 40-60S	6000	6,73
F		
KHU 40-02F	200	0,24
KHU 40-03F	300	0,36
KHU 40-04F	400	0,48
KHU 40-05F	500	0,60
KHU 40-06F	600	0,72
KHU 40-07F	700	0,84
KHU 40-08F	800	0,96
KHU 40-09F	900	1,10
KHU 40-10F	1000	1,20
KHU 40-11F	1100	1,32
KHU 40-12F	1200	1,44
KHU 40-13F	1300	1,60
KHU 40-14F	1400	1,70
KHU 40-15F	1500	1,80
KHU 40-30F	3000	3,60
KHU 40-60F	6000	7,20

accessories optional:

KDU 40	bracket support, 40x30mm	(page F17)
BGU 40	head plate, profile U40	(page F28)
KWF	bracket, light duty	(page F05)
KW	bracket, standard	(page F05)
KHUV 40	coupler	(page F32)
KHUSS 40	support piece	(page F33)
SU 40	protection end cap	(page F37)
BGUD	head plate, profile U40/ U57/ U60	(page F31)
BGUDW	head plate, profile U40/ U57/ U60	(page F31)

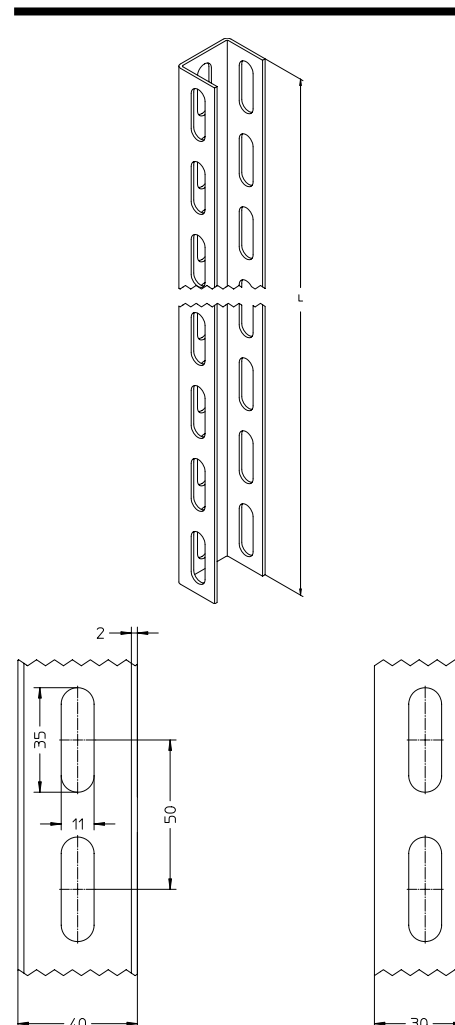

Support systems

KHU-system

KHU 40 bracket support, 40x30mm

Ceiling bracket support, U-profile 40 x 30mm, continuously three-way perforated.

It is recommended to apply the support piece from a bracket width of 400mm or if the bracket is installed at the end of the ceiling fixed bracket.

For assembly instructions, see the chapter assembly.

article number	L mm	G kg
E		
KHU 40-02E	200	0,23
KHU 40-03E	300	0,34
KHU 40-04E	400	0,45
KHU 40-05E	500	0,57
KHU 40-06E	600	0,68
KHU 40-07E	700	0,79
KHU 40-08E	800	0,90
KHU 40-09E	900	1,02
KHU 40-10E	1000	1,13
KHU 40-11E	1100	1,24
KHU 40-12E	1200	1,36
KHU 40-13E	1300	1,47
KHU 40-14E	1400	1,60
KHU 40-15E	1500	1,70
KHU 40-30E	3000	3,40
KHU 40-60E	6000	6,80
E4		
KHU 40-02E4	200	0,23
KHU 40-03E4	300	0,34
KHU 40-04E4	400	0,46
KHU 40-05E4	500	0,57
KHU 40-06E4	600	0,69
KHU 40-07E4	700	0,80
KHU 40-08E4	800	0,92
KHU 40-09E4	900	1,03
KHU 40-10E4	1000	1,14
KHU 40-11E4	1100	1,26
KHU 40-12E4	1200	1,40
KHU 40-13E4	1300	1,50
KHU 40-14E4	1400	1,60
KHU 40-15E4	1500	1,72
KHU 40-30E4	3000	3,43
KHU 40-60E4	6000	6,90

accessories optional:

KDU 40	bracket support, 40x30mm	(page F17)
BGU 40	head plate, profile U40	(page F28)
KWF	bracket, light duty	(page F05)
KW	bracket, standard	(page F05)
KHUV 40	coupler	(page F32)
KHUSS 40	support piece	(page F33)
SU 40	protection end cap	(page F37)
BGUD	head plate, profile U40/ U57/ U60	(page F31)
BGUDW	head plate, profile U40/ U57/ U60	(page F31)

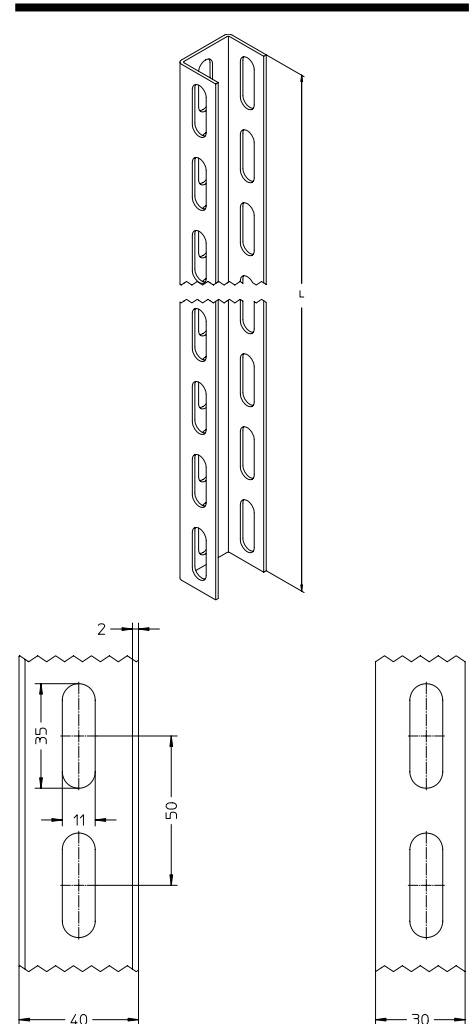

Support systems

KHU-system

KHU 57 bracket support, 57x30mm

Ceiling bracket support, U-profile 57 x 30mm, continuously three-way perforated.

It is recommended to apply the support piece from a bracket width of 400mm or if the bracket is installed at the end of the ceiling fixed bracket.

For assembly instructions, see the chapter assembly.

article number	L mm	G kg
S		
KHU 57-02S	200	0,34
KHU 57-03S	300	0,51
KHU 57-04S	400	0,68
KHU 57-05S	500	0,85
KHU 57-06S	600	1,02
KHU 57-07S	700	1,19
KHU 57-08S	800	1,36
KHU 57-09S	900	1,53
KHU 57-10S	1000	1,70
KHU 57-11S	1100	1,87
KHU 57-12S	1200	2,04
KHU 57-13S	1300	2,21
KHU 57-14S	1400	2,38
KHU 57-15S	1500	2,55
KHU 57-30S	3000	5,09
KHU 57-60S	6000	10,18

F		
KHU 57-02F	200	0,36
KHU 57-03F	300	0,55
KHU 57-04F	400	0,73
KHU 57-05F	500	0,91
KHU 57-06F	600	1,09
KHU 57-07F	700	1,27
KHU 57-08F	800	1,45
KHU 57-09F	900	1,63
KHU 57-10F	1000	1,82
KHU 57-11F	1100	2,00
KHU 57-12F	1200	2,18
KHU 57-13F	1300	2,36
KHU 57-14F	1400	2,54
KHU 57-15F	1500	2,72
KHU 57-30F	3000	5,45
KHU 57-60F	6000	10,89

accessories optional:

BGU 57	head plate, profile U57	(page F28)
KWF	bracket, light duty	(page F05)
KW	bracket, standard	(page F05)
KWMS	wall bracket, medium duty	(page F06)
KDU 57	bracket support, 57x30mm	(page F19)
KHUV 57	coupler	(page F32)
KHUSS 57	support piece	(page F34)
SU 57	protection end cap	(page F37)
BGUD	head plate, profile U40/ U57/ U60	(page F31)
BGUDW	head plate, profile U40/ U57/ U60	(page F31)

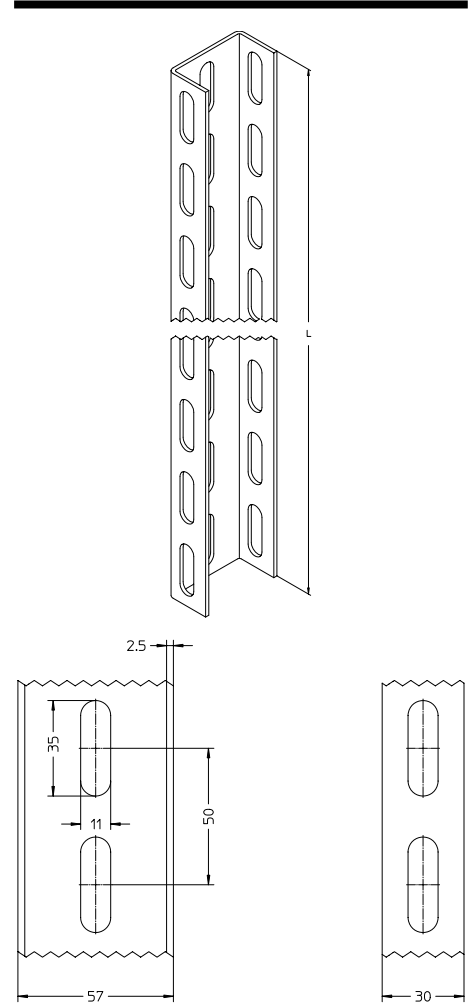

Support systems

KHU-system

KHU 57 bracket support, 57x30mm

Ceiling bracket support, U-profile 57 x 30mm, continuously three-way perforated.

It is recommended to apply the support piece from a bracket width of 400mm or if the bracket is installed at the end of the ceiling fixed bracket.

For assembly instructions, see the chapter assembly.

article number	L mm	G kg
E		
KHU 57-02E	200	0,34
KHU 57-03E	300	0,51
KHU 57-04E	400	0,68
KHU 57-05E	500	0,85
KHU 57-06E	600	1,03
KHU 57-07E	700	1,20
KHU 57-08E	800	1,37
KHU 57-09E	900	1,54
KHU 57-10E	1000	1,71
KHU 57-11E	1100	1,88
KHU 57-12E	1200	2,05
KHU 57-13E	1300	2,22
KHU 57-14E	1400	2,39
KHU 57-15E	1500	2,56
KHU 57-30E	3000	5,12
KHU 57-60E	6000	10,25
E4		
KHU 57-02E4	200	0,35
KHU 57-03E4	300	0,52
KHU 57-04E4	400	0,69
KHU 57-05E4	500	0,87
KHU 57-06E4	600	1,04
KHU 57-07E4	700	1,21
KHU 57-08E4	800	1,38
KHU 57-09E4	900	1,56
KHU 57-10E4	1000	1,73
KHU 57-11E4	1100	1,90
KHU 57-12E4	1200	2,08
KHU 57-13E4	1300	2,25
KHU 57-14E4	1400	2,42
KHU 57-15E4	1500	2,59
KHU 57-30E4	3000	5,19
KHU 57-60E4	6000	10,38

accessories optional:

BGU 57	head plate, profile U57	(page F28)
KWF	bracket, light duty	(page F05)
KW	bracket, standard	(page F05)
KWMS	wall bracket, medium duty	(page F06)
KDU 57	bracket support, 57x30mm	(page F19)
KHUV 57	coupler	(page F32)
KHUSS 57	support piece	(page F34)
SU 57	protection end cap	(page F37)
BGUD	head plate, profile U40/ U57/ U60	(page F31)
BGUDW	head plate, profile U40/ U57/ U60	(page F31)

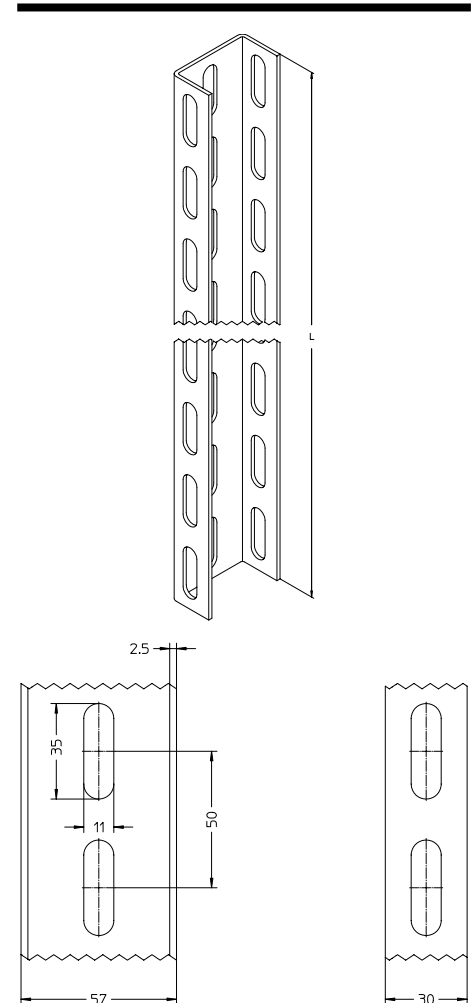

Support systems

KHU-system

KHU 60 bracket support, profile U60

This article is also available made in stainless steel finish, material No. 1.4571 / 1.4404 (V4A).
 For an application example, see the chapter assembly.
 For assembly instructions, see the chapter assembly.

article number	H mm	B mm	L mm	G kg
F				
KHU 60-02F	40	60	200	0,70
KHU 60-03F	40	60	300	1,10
KHU 60-04F	40	60	400	1,40
KHU 60-05F	40	60	500	1,80
KHU 60-06F	40	60	600	2,10
KHU 60-07F	40	60	700	2,50
KHU 60-08F	40	60	800	2,80
KHU 60-09F	40	60	900	3,20
KHU 60-10F	40	60	1000	3,50
KHU 60-11F	40	60	1100	3,90
KHU 60-12F	40	60	1200	4,20
KHU 60-13F	40	60	1300	4,60
KHU 60-14F	40	60	1400	4,90
KHU 60-15F	40	60	1500	5,30
KHU 60-20F	40	60	2000	7,00
KHU 60-30F	40	60	3000	10,50
KHU 60-60F	40	60	6000	21,10
E				
KHU 60-30E	40	60	3000	10,50

accessories optional:

BGU 60	head plate, profile U60	(page F29)
SU 60	protection end cap, profile U60	(page F37)
KW	bracket, standard	(page F05)
WPHS-K	flange mounting clamp (brackets)	(page D21)
KLS	fixing set	(page G33)

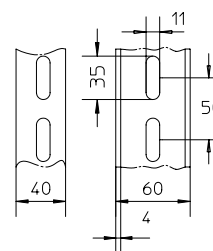
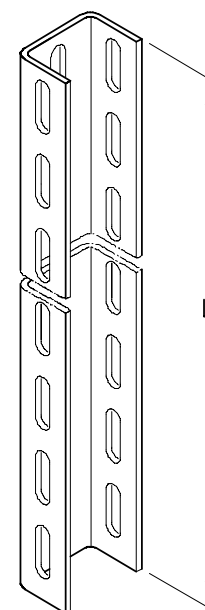

Support systems

KHU-system

KHU 80 bracket support, profile U80

article number	H mm	B mm	L mm	G kg
F				
KHU 80-02F	80	60	200	1,33
KHU 80-03F	80	60	300	2,00
KHU 80-04F	80	60	400	2,66
KHU 80-05F	80	60	500	3,33
KHU 80-06F	80	60	600	3,99
KHU 80-07F	80	60	700	4,66
KHU 80-08F	80	60	800	5,32
KHU 80-09F	80	60	900	5,99
KHU 80-10F	80	60	1000	6,65
KHU 80-11F	80	60	1100	7,32
KHU 80-12F	80	60	1200	7,98
KHU 80-13F	80	60	1300	8,65
KHU 80-14F	80	60	1400	9,32
KHU 80-15F	80	60	1500	9,98
KHU 80-16F	80	60	1600	10,65
KHU 80-17F	80	60	1700	11,31
KHU 80-18F	80	60	1800	11,98
KHU 80-19F	80	60	1900	12,64
KHU 80-20F	80	60	2000	13,31
KHU 80-30F	80	60	3000	19,96
KHU 80-60F	80	60	6000	39,92

accessories optional:

KW	bracket, standard	(page F05)
WPHS-K	flange mounting clamp (brackets)	(page D21)
KLS	fixing set	(page G33)

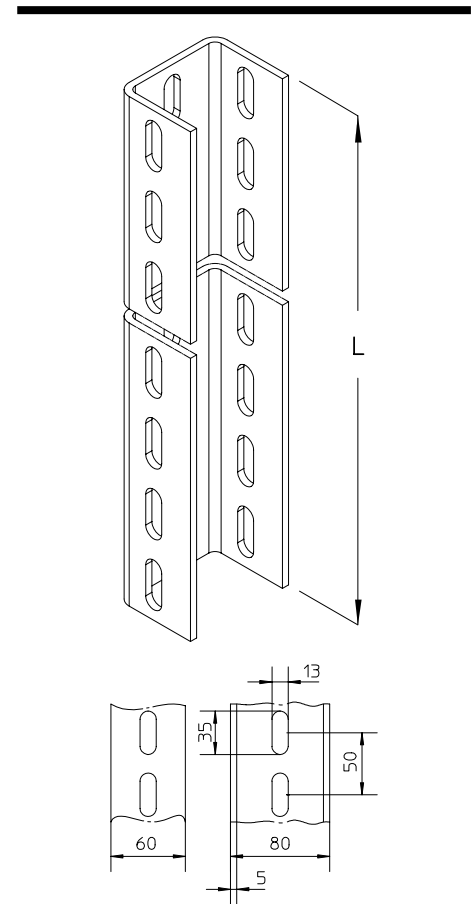

F

Support systems

KHU-system

BGU 40 head plate, profile U40

Head plate for ceiling mounting of KHU 40 bracket support KHU 40
For assembly instructions, see the chapter assembly.

article number	H mm	B mm	L mm	t mm	G kg
F					
BGU 40F	100	40	120	4	0,37

accessories included:

2 x FRSV 10x20F	round-head screw with short square	(page G34)
2 x US 10x21F	square washer, DIN 125	(page G39)
2 x SEM 10F	hexagon-nut, DIN 934	(page G41)

article number	H mm	B mm	L mm	t mm	G kg
E					
BGU 40E	100	40	120	4	0,35

accessories included:

2 x FRSV 10x20E	round-head screw with short square	(page G35)
2 x US 10x21E	square washer, DIN 125	(page G40)
2 x SEM 10E	hexagon-nut, DIN 934	(page G41)

article number	H mm	B mm	L mm	t mm	G kg
E4					
BGU 40E4	100	40	120	4	0,35

accessories included:

2 x FRSV 10x20E4	round-head screw with short square	(page G35)
2 x US 10x21E4	square washer, DIN 125	(page G40)
2 x SEM 10E4	hexagon-nut, DIN 934	(page G41)

BGU 57 head plate, profile U57

Head plate for ceiling mounting of bracket support KHU 57
For assembly instructions, see the chapter assembly.

article number	H mm	B mm	L mm	t mm	G kg
F					
BGU 57F	100	40	160	5	0,54

accessories included:

2 x FRSV 10x20F	round-head screw with short square	(page G34)
2 x US 10x21F	square washer, DIN 125	(page G39)
2 x SEM 10F	hexagon-nut, DIN 934	(page G41)

article number	H mm	B mm	L mm	t mm	G kg
E					
BGU 57E	100	40	160	5	0,52

accessories included:

2 x FRSV 10x20E	round-head screw with short square	(page G35)
2 x US 10x21E	square washer, DIN 125	(page G40)
2 x SEM 10E	hexagon-nut, DIN 934	(page G41)

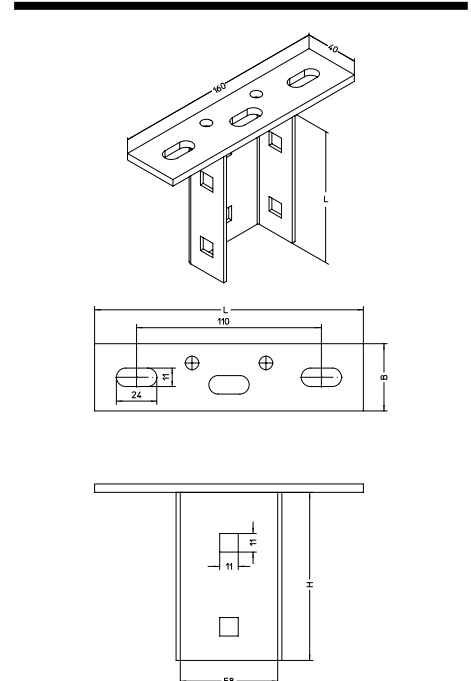
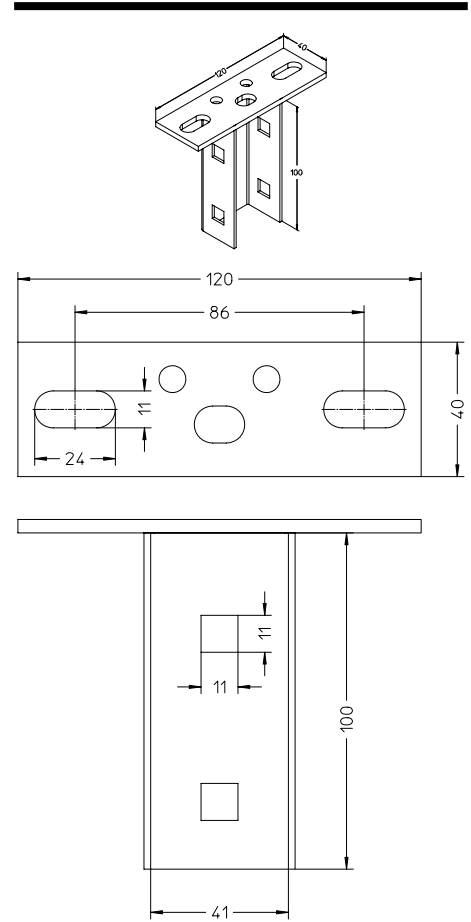

Support systems

KHU-system

BGU 57 head plate, profile U57

Head plate for ceiling mounting of bracket support KHU 57
For assembly instructions, see the chapter assembly.

article number	H mm	B mm	L mm	t mm	G kg
E4					
BGU 57E4	100	40	160	5	0,52

accessories included:

2 x FRSV 10x20E4	round-head screw with short square	(page G35)
2 x US 10x21E4	square washer, DIN 125	(page G40)
2 x SEM 10E4	hexagon-nut, DIN 934	(page G41)

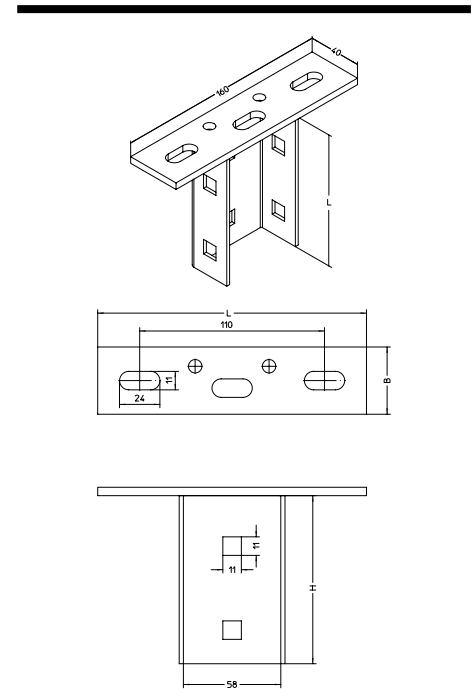

BGU 60 head plate, profile U60

This article is also available made in stainless steel finish, material No. 1.4571 / 1.4404 (V4A).
For an application example, see the chapter assembly.
For assembly instructions, see the chapter assembly.

article number	H mm	B mm	L mm	G kg
F				
BGU 60F	120	80	200	1,28

accessories included :

4 x SES 10x25F	hexagon head bolt, DIN 933	(page G38)
4 x US 10x21F	square washer, DIN 125	(page G39)
4 x SEM 10F	hexagon-nut, DIN 934	(page G41)

article number	H mm	B mm	L mm	G kg
E				
BGU 60E	120	80	200	1,30

accessories included:

4 x SES 10x20E	hexagon head bolt, DIN 933	(page G38)
4 x US 10x21E	square washer, DIN 125	(page G40)
4 x SEM 10E	hexagon-nut, DIN 934	(page G41)

article number	H mm	B mm	L mm	G kg
E4				
BGU 60E4	120	80	200	1,30

accessories included:

4 x SES 10x20E4	hexagon head bolt, DIN 933	(page G38)
4 x US 10x21E4	square washer, DIN 125	(page G40)
4 x SEM 10E4	hexagon-nut, DIN 934	(page G41)

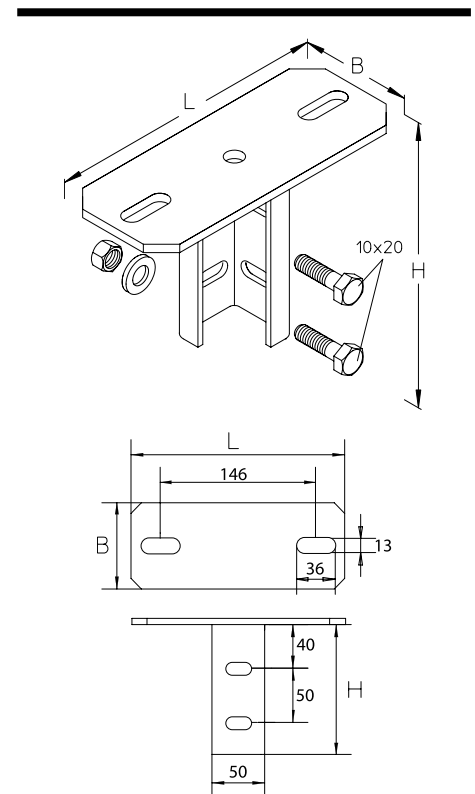

Support systems

KHU-system

BGU 80 head plate, profile U80

This article is also available made in stainless steel finish, material No. 1.4571 / 1.4404 (V4A).
For assembly instructions, see the chapter assembly.

article number	H mm	B mm	L mm	G kg
F				
BGU 80F	120	80	200	2,05

accessories included:

4 x SEM 12F	hexagon-nut, DIN 934	(page G41)
4 x US 13x24F	square washer, DIN 125	(page G39)
4 x SES 12x20F	hexagon head bolt, DIN 933	(page G38)

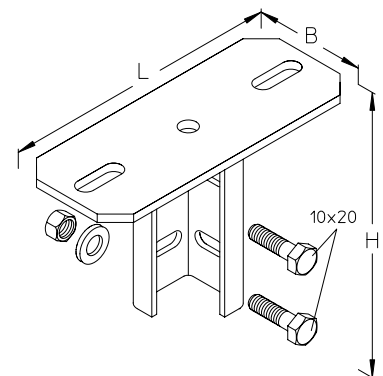

BGUQ head plate, profile U50

article number	H mm	B mm	L mm	G kg
F				
BGUQ 50F	156	80	150	0,86

accessories included:

2 x SEM 10F	hexagon-nut, DIN 934	(page G41)
2 x US 10x21F	square washer, DIN 125	(page G39)
2 x FRSV 10x20F	round-head screw with short square	(page G34)

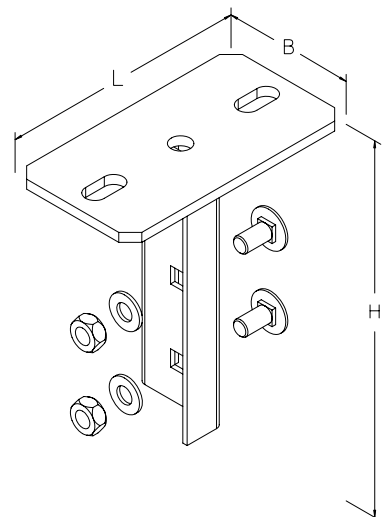

article number	H mm	B mm	L mm	G kg
E				
BGUQ 50E	156	80	150	0,86

accessories included:

2 x SEM 10E	hexagon-nut, DIN 934	(page G41)
2 x US 10x21E4	square washer, DIN 125	(page G40)
2 x US 10x21E	square washer, DIN 125	(page G40)
2 x FRSV 10x20E	round-head screw with short square	(page G35)

accessories optional:

SD	expansion anchor	(page G12)
-----------	------------------	------------

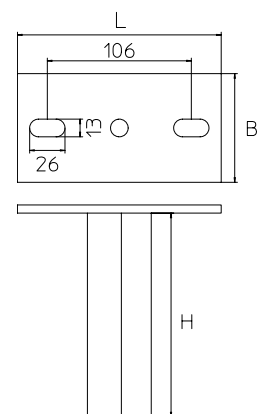

Support systems

KHU-system

BGUD head plate, profile U40/ U57/ U60

This article is also available made in stainless steel finish, material No. 1.4571 / 1.4404 (V4A).
For an application example, see the chapter assembly.

article number	H mm	B mm	L mm	G kg
F				
BGUD F	125	80	200	1,30

accessories included:

2 x SES 10x20F	hexagon head bolt, DIN 933	(page G38)
2 x SEM 10F	hexagon-nut, DIN 934	(page G41)
2 x US 10x30F	square washer, DIN 9021	(page G40)

article number	H mm	B mm	L mm	G kg
E				
BGUD E	125	80	200	1,40

accessories included:

2 x SES 10x20E	hexagon head bolt, DIN 933	(page G38)
2 x SEM 10E	hexagon-nut, DIN 934	(page G41)
2 x US 10x30E	square washer, DIN 9021	(page G40)

accessories optional:

SD	expansion anchor	(page G12)
-----------	------------------	------------

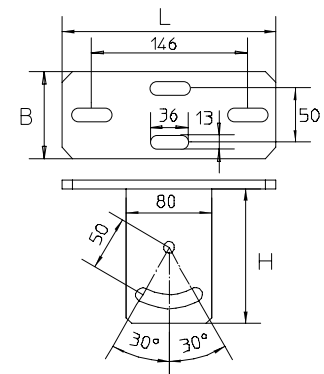
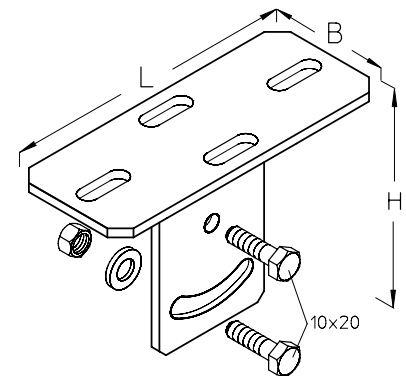

BGUDW head plate, profile U40/ U57/ U60

This article is also available made in stainless steel finish, material No. 1.4571 / 1.4404 (V4A).
For an application example, see the chapter assembly.

article number	H mm	B mm	L mm	G kg
F				
BGUDW F	120	80	200	1,40

accessories included:

2 x SES 10x20F	hexagon head bolt, DIN 933	(page G38)
2 x SEM 10F	hexagon-nut, DIN 934	(page G41)
2 x US 10x30F	square washer, DIN 9021	(page G40)

accessories optional:

SD	expansion anchor	(page G12)
-----------	------------------	------------

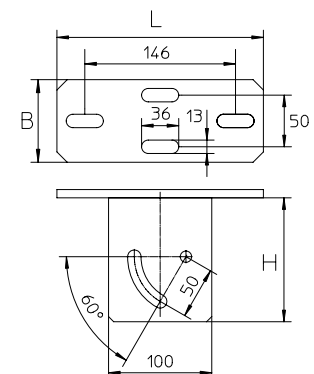
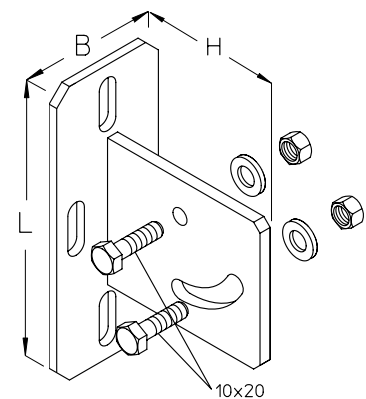

Support systems

KHU-system

KHUV 40 coupler

article number	H mm	B mm	L mm	t mm	G kg
S					
KHUV 40S	45	32	210	2,5	0,45

accessories included:

4 x SEM 10	hexagon-nut, DIN 934	(page G41)
4 x US 10x21	square washer, DIN 125	(page G39)
4 x FRSV 10x20	round-head screw with short square	(page G34)

article number	H mm	B mm	L mm	t mm	G kg
F					
KHUV 40F	45	32	210	2,5	0,47

accessories included:

4 x SEM 10F	hexagon-nut, DIN 934	(page G41)
4 x US 10x21F	square washer, DIN 125	(page G39)
4 x FRSV 10x20F	round-head screw with short square	(page G34)

article number	H mm	B mm	L mm	t mm	G kg
E					
KHUV 40E	45	32	210	2,5	0,45

accessories included:

4 x SEM 10E	hexagon-nut, DIN 934	(page G41)
4 x US 10x21E	square washer, DIN 125	(page G40)
4 x FRSV 10x20E	round-head screw with short square	(page G35)

article number	H mm	B mm	L mm	t mm	G kg
E4					
KHUV 40E4	45	32	210	2,5	0,46

accessories included:

4 x SEM 10E4	hexagon-nut, DIN 934	(page G41)
4 x US 10x21E4	square washer, DIN 125	(page G40)
4 x FRSV 10x20E4	round-head screw with short square	(page G35)

KHUV 57 coupler

article number	H mm	B mm	L mm	t mm	G kg
S					
KHUV 57S	63	32,5	210	2,5	0,60

accessories included:

4 x SEM 10	hexagon-nut, DIN 934	(page G41)
4 x US 10x21	square washer, DIN 125	(page G39)
4 x FRSV 10x20	round-head screw with short square	(page G34)

article number	H mm	B mm	L mm	t mm	G kg
F					
KHUV 57F	63	32,5	210	2,5	0,63

accessories included:

4 x SEM 10F	hexagon-nut, DIN 934	(page G41)
4 x US 10x21F	square washer, DIN 125	(page G39)
4 x FRSV 10x20F	round-head screw with short square	(page G34)

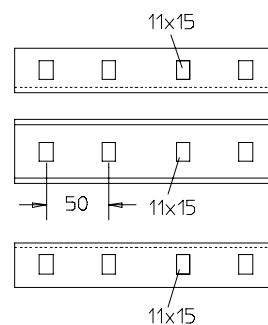
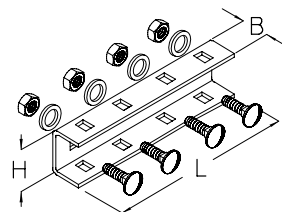
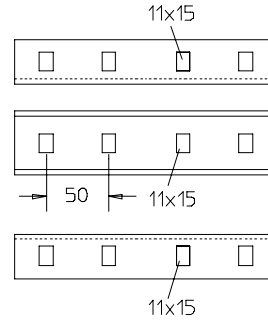
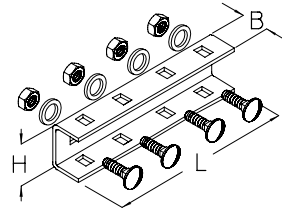

Support systems

KHU-system

KHUV 57 coupler

article number	H mm	B mm	L mm	t mm	G kg
E					
KHUV 57E	63	32,5	210	2,5	0,60

accessories included:

4 x SEM 10E	hexagon-nut, DIN 934	(page G41)
4 x US 10x21E	square washer, DIN 125	(page G40)
4 x FRSV 10x20E	round-head screw with short square	(page G35)

article number	H mm	B mm	L mm	t mm	G kg
E4					
KHUV 57E4	63	32,5	210	2,5	0,61

accessories included:

4 x SEM 10E4	hexagon-nut, DIN 934	(page G41)
4 x US 10x21E4	square washer, DIN 125	(page G40)
4 x FRSV 10x20E4	round-head screw with short square	(page G35)

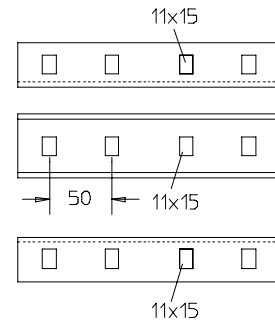
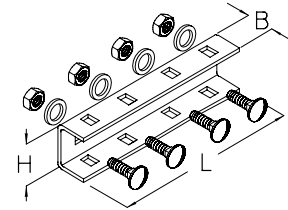

KHUV 60 coupler, profile U60

For an application example, see the chapter assembly.

article number	H mm	B mm	L mm	G kg
F				
KHUV 60F	51	35	210	0,80

accessories included:

4 x KLS 10x20F	fixing set	(page G34)
-----------------------	------------	------------

article number	H mm	B mm	L mm	G kg
E				
KHUV 60E	51	35	210	0,89

article number	H mm	B mm	L mm	G kg
E4				
KHUV 60E4	51	35	210	0,89

accessories included:

4 x KLS 10x20E	fixing set	(page G34)
-----------------------	------------	------------

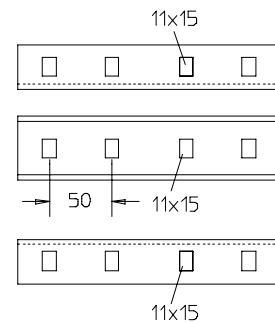
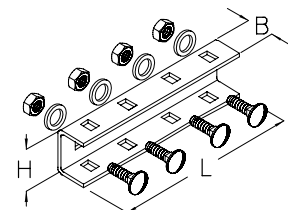

KHUSS 40 support piece

For an application example, see the chapter assembly.

article number	G kg
S	
KHUSS 40S	0,11

accessories included:

1 x SEM 10	hexagon-nut, DIN 934	(page G41)
2 x US 10x21	square washer, DIN 125	(page G39)
1 x SES 10x75	hexagon head bolt, DIN 933	(page G37)

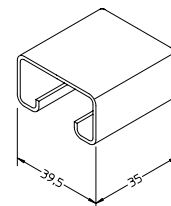

KHUSS 40 support piece

For an application example, see the chapter assembly.

article number	G
	kg
F	
KHUSS 40F	0,11

accessories included:

1 x SEM 10F	hexagon-nut, DIN 934	(page G41)
2 x US 10x21F	square washer, DIN 125	(page G39)
1 x SES 10x75F	hexagon head bolt, DIN 933	(page G38)

article number	G
	kg
E	
KHUSS 40E	0,11

accessories included:

1 x SEM 10E	hexagon-nut, DIN 934	(page G41)
2 x US 10x21E	square washer, DIN 125	(page G40)
1 x SES 10x75E	hexagon head bolt, DIN 933	(page G38)

article number	G
	kg
E4	
KHUSS 40E4	0,11

accessories included:

1 x SEM 10E4	hexagon-nut, DIN 934	(page G41)
2 x US 10x21E4	square washer, DIN 125	(page G40)
1 x SES 10x75E4	hexagon head bolt, DIN 933	(page G38)

KHUSS 57 support piece

For an application example, see the chapter assembly.

article number	G
	kg
S	
KHUSS 57S	0,14

accessories included:

1 x SEM 10	hexagon-nut, DIN 934	(page G41)
2 x US 10x21	square washer, DIN 125	(page G39)
1 x SES 10x100	hexagon head bolt, DIN 933	(page G37)

article number	G
	kg
F	
KHUSS 57F	0,14

accessories included:

1 x SEM 10F	hexagon-nut, DIN 934	(page G41)
2 x US 10x21F	square washer, DIN 125	(page G39)
1 x SES 10x100F	hexagon head bolt, DIN 933	(page G38)

article number	G
	kg
E	
KHUSS 57E	0,14

accessories included:

1 x SEM 10E	hexagon-nut, DIN 934	(page G41)
2 x US 10x21E	square washer, DIN 125	(page G40)
1 x SES 10x100E	hexagon head bolt, DIN 933	(page G38)

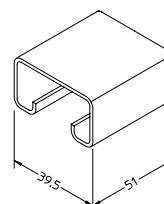
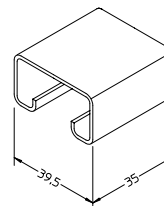

Support systems

KHU-system

KHUSS 57 support piece

For an application example, see the chapter assembly.

article number	G kg
E4	
KHUSS 57E4	0,14

accessories included:

- 1 x **SEM 10E4** hexagon-nut, DIN 934 (page G41)
- 2 x **US 10x21E4** square washer, DIN 125 (page G40)
- 1 x **SES 10x100E4** hexagon head bolt, DIN 933 (page G38)

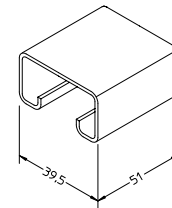

KHUSS 60 support piece

For an application example, see the chapter assembly.

article number	G kg
S	
KHUSS 60S	0,18

accessories included:

- 1 x **SES 10x100** hexagon head bolt, DIN 933 (page G37)
- 2 x **US 10x21** square washer, DIN 125 (page G39)
- 1 x **SEM 10** hexagon-nut, DIN 934 (page G41)

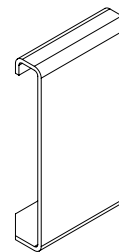

article number	G kg
F	
KHUSS 60F	0,19

accessories included:

- 2 x **US 10x21F** square washer, DIN 125 (page G39)
- 1 x **SEM 10F** hexagon-nut, DIN 934 (page G41)
- 1 x **SES 10x100F** hexagon head bolt, DIN 933 (page G38)

BL 4 corner angle, profile U50/ U60/ U100

This article is also available made in stainless steel finish, material No. 1.4571 / 1.4404 (V4A).
For an application example, see the chapter assembly.

article number	H mm	B mm	L mm	t mm	G kg
F					
BL 4F	40	82,5	54	4	0,15
E					
BL 4E	40	82,5	54	4	0,15

accessories optional:

- SD** expansion anchor (page G12)
- KLS** fixing set (page G33)

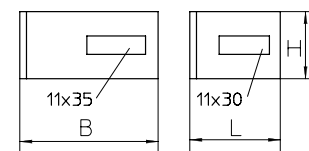
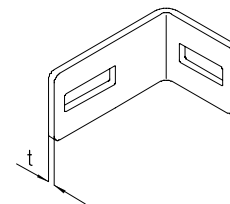

Support systems

KHU-system

BLD adaptor diagonal

For an application example, see the chapter assembly.

article number	H mm	B mm	L mm	G kg
F				
BLD F	100	37	80	0,50

accessories optional:

SD	expansion anchor	(page G12)
SES	hexagon head bolt, DIN 933	(page G37)
AM22	channel nut, A41/ KHA 41/ KHAL 41	(page G43)
AMF22	channel spring nut, A41	(page G43)
HS18	tee-head bolt, A7/ A8/ A9	(page G45)
AMF18	channel spring nut, A7/ A8	(page G45)

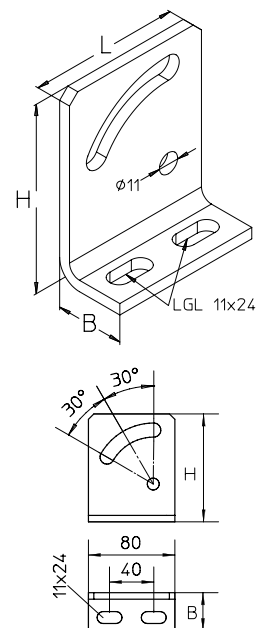

KB junction plate

For an application example, see the chapter assembly.

article number	H mm	L mm	t mm	G kg
F				
KB F	150	150	3	0,40

accessories included:

4 x **KLS 10x20F** fixing set (page G34)

article number	H mm	L mm	t mm	G kg
E				
KB E	150	150	2	0,40

accessories included:

4 x **KLS 10x20E** fixing set (page G34)

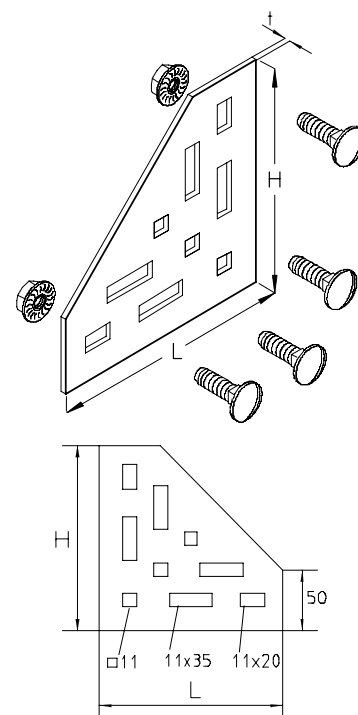

Support systems

KHU-system

SU 40 protection end cap

article number	B mm	G kg
PE		
SU 40	44	0,01

accessories optional:

- KDU 40** bracket support, 40x30mm (page F17)
KHU 40 bracket support, 40x30mm (page F22)

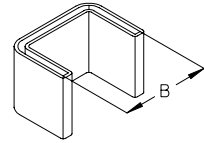

SU 57 protection end cap

article number	B mm	G kg
PE		
SU 57	61	0,02

accessories optional:

- KDU 57** bracket support, 57x30mm (page F19)
KHU 57 bracket support, 57x30mm (page F24)

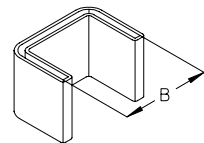

SU 60 protection end cap, profile U60

For an application example, see the chapter assembly.

article number	B mm	G kg
PE		
SU 60	60	0,02

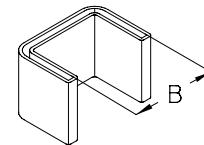

KZS cold zinc spray

For assembly instructions, see the chapter assembly.

article number	I ml	G kg
KZS		
	400	0,40

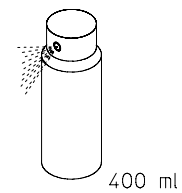

KZF cold zinc paint

For assembly instructions, see the chapter assembly.

article number	I ml	G kg
KZF		
	750	1,93

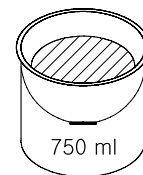

Support systems

KHI-system

KDI bracket support, heavy, profile I80

F_D/P : coefficient for calculation of the dowel load F_D with effective bracket load P respectively the sum of effective bracket loads.

For an application example, see the chapter assembly.

For assembly instructions, see the chapter assembly.



article number	L mm	t mm	G kg
F			
KDI 02F	200	6	1,90
KDI 03F	300	6	2,50
KDI 04F	400	6	3,00
KDI 05F	500	6	3,60
KDI 06F	600	6	4,20
KDI 07F	700	6	4,80
KDI 08F	800	6	5,40
KDI 09F	900	6	6,00
KDI 10F	1000	6	6,60
KDI 11F	1100	8	7,40
KDI 12F	1200	8	8,00
KDI 13F	1300	8	8,60
KDI 14F	1400	8	9,10
KDI 15F	1500	8	9,70
KDI 16F	1600	8	10,30
KDI 17F	1700	8	10,90
KDI 18F	1800	8	11,50
KDI 19F	1900	8	12,10
KDI 20F	2000	8	12,70
KDI 21F	2100	8	13,20
KDI 22F	2200	8	13,80
KDI 23F	2300	8	14,40
KDI 24F	2400	8	15,00
KDI 25F	2500	8	15,60
KDI 26F	2600	8	16,20
KDI 27F	2700	8	16,80
KDI 28F	2800	8	17,30
KDI 29F	2900	8	17,90
KDI 30F	3000	8	18,50

accessories optional:

KT	bracket, standard, profile I80	(page F40)
KTS	bracket, heavy, profile I80	(page F40)
KTSS	bracket, very heavy, profile I80	(page F41)
SD	expansion anchor	(page G12)
SI	protection end cap, yellow	(page F46)

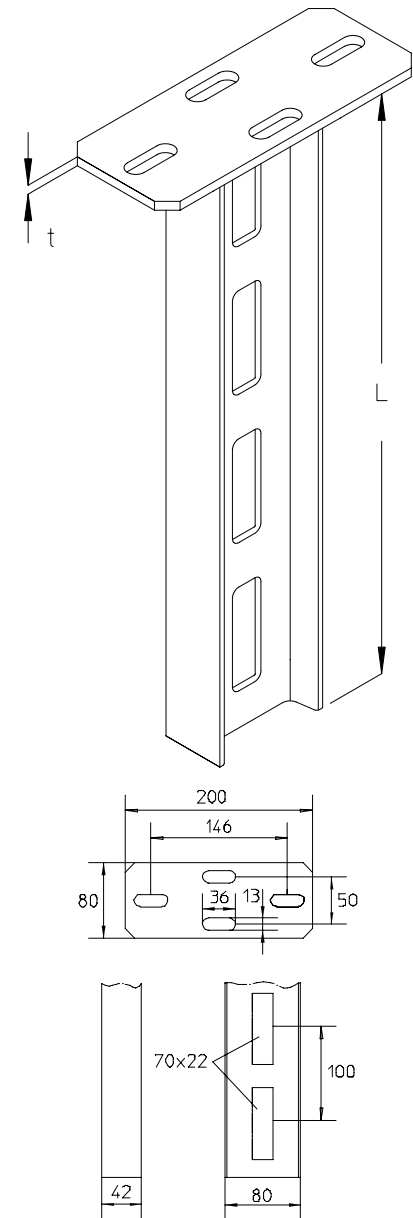

Support systems

KHI-system

KHI bracket support, type KT

For an application example, see the chapter assembly.
For assembly instructions, see the chapter assembly.

article number	H mm	B mm	L mm	G kg
F				
KHI 02F	80	42	200	1,10
KHI 03F	80	42	300	1,70
KHI 04F	80	42	400	2,30
KHI 05F	80	42	500	2,90
KHI 06F	80	42	600	3,50
KHI 07F	80	42	700	4,10
KHI 08F	80	42	800	4,70
KHI 09F	80	42	900	5,30
KHI 10F	80	42	1000	5,90
KHI 11F	80	42	1100	6,40
KHI 12F	80	42	1200	7,10
KHI 13F	80	42	1300	7,60
KHI 14F	80	42	1400	8,20
KHI 15F	80	42	1500	8,80
KHI 16F	80	42	1600	9,40
KHI 17F	80	42	1700	10,00
KHI 18F	80	42	1800	10,60
KHI 19F	80	42	1900	11,10
KHI 20F	80	42	2000	11,70
KHI 21F	80	42	2100	12,30
KHI 22F	80	42	2200	12,90
KHI 23F	80	42	2300	13,50
KHI 24F	80	42	2400	14,10
KHI 25F	80	42	2500	14,60
KHI 26F	80	42	2600	15,20
KHI 27F	80	42	2700	15,80
KHI 28F	80	42	2800	16,30
KHI 29F	80	42	2900	16,90
KHI 30F	80	42	3000	17,50
KHI 60F	80	42	6000	35,10

accessories optional:

KT	bracket, standard, profile I80	(page F40)
KTSS	bracket, very heavy, profile I80	(page F41)
BL 7	corner angle	(page E23, F45)
BL 3	corner angle	(page F44)
BLI	corner angle	(page F45)
BGI	head plate, profile I80	(page E22, F41)
BGIQ	head plate, profile I80	(page E23, F42)
BGID	head plate, profile I80	(page F43)
HKI	support connector	(page E22, F43)
HKIW	support connector	(page F44)
HKIQ	support connector	(page F44)

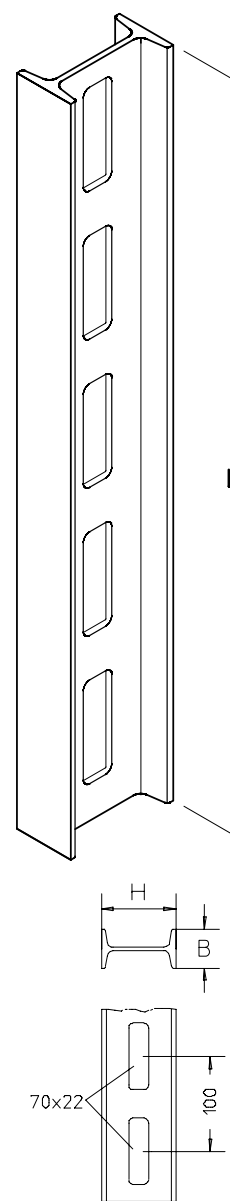

Support systems

KHI-system

KT bracket, standard, profile I80

For an application example, see the chapter assembly.

article number	H mm	B mm	L mm	P_{max} kN	G kg
F					
KT 010F	50	100	120	2,0	0,24
KT 020F	70	200	220	2,0	0,56
KT 030F	70	300	320	2,0	0,77
KT 040F	90	400	420	2,0	0,87
KT 050F	110	500	520	2,0	1,40
KT 060F	110	600	620	2,1	1,55

accessories optional:

KLU fixing set (page G07)

KLR fixing set (page G33)

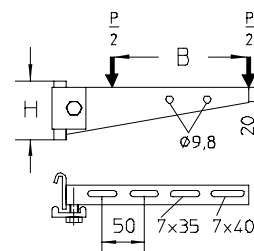
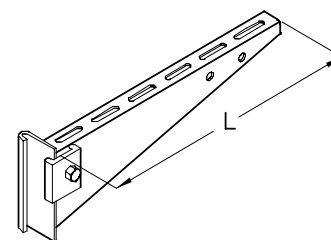

KTS bracket, heavy, profile I80

article number	H mm	B mm	L mm	P_{max} kN	G kg
F					
KTS 020F	180	200	280	7,0	1,64
KTS 030F	180	300	380	6,3	2,00
KTS 040F	180	400	480	5,5	2,38
KTS 050F	180	500	580	4,9	2,74
KTS 060F	180	600	680	4,3	3,10
KTS 070F	180	600	780	3,6	3,47
KTS 080F	180	600	880	3,0	3,83
KTS 090F	180	600	980	2,3	4,19
KTS 100F	180	600	1080	1,7	4,56

accessories optional:

WPHS-K flange mounting clamp (brackets) (page D21)

KLU fixing set (page G07)

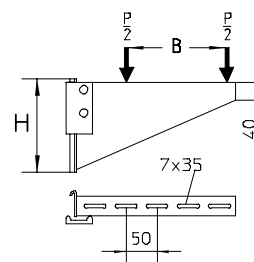
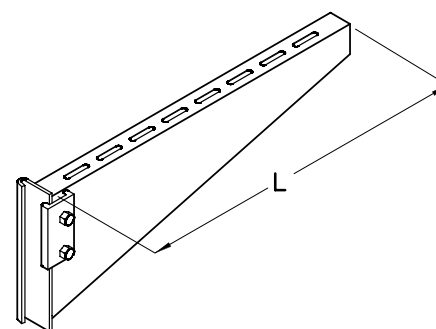

Support systems

KHI-system

KTSS bracket, very heavy, profile I80

For an application example, see the chapter assembly.

article number	H mm	B mm	L mm	P _{max} kN	G kg
F					
KTSS 020F	100	200	280	12	2,94
KTSS 030F	135	300	380	12	3,53
KTSS 040F	165	400	480	12	4,12
KTSS 050F	200	500	580	12	4,71
KTSS 060F	230	600	680	12	6,34

accessories optional:

- WPHS-A** flange mounting clamp (C-profiles) (page D22)
WPHS-K flange mounting clamp (brackets) (page D21)

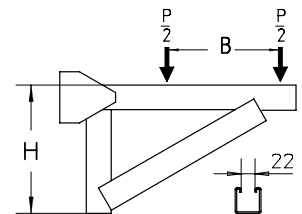
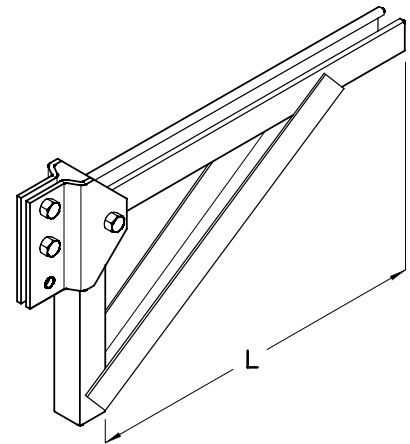

BGI head plate, profile I80

article also available with other inclinations

For an application example, see the chapter assembly.

For assembly instructions, see the chapter assembly.

article number	H mm	B mm	L mm	G kg
F				
BGI F	165	80	200	1,40

accessories included:

- 2 x **FRS 10x30F** round-head screw with square, DIN 603 (page G35)
 2 x **SEM 10F** hexagon-nut, DIN 934 (page G41)

accessories optional:

- SD** expansion anchor (page G12)

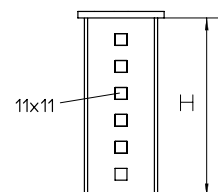
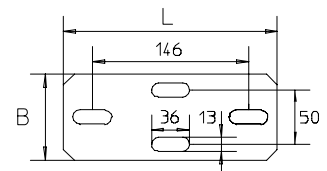
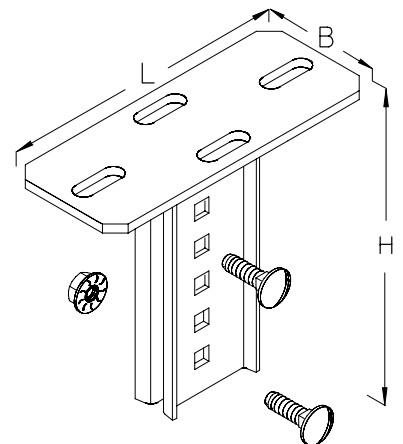

Support systems

KHI-system

BGIQ head plate, profile I80

For an application example, see the chapter assembly.



article number	H mm	B mm	L mm	G kg
F				
BGIQ F	165	80	200	1,40

accessories included:

- 2 x **FRS 10x30F** round-head screw with square, DIN 603 (page G35)
- 2 x **SEM 10F** hexagon-nut, DIN 934 (page G41)

accessories optional:

- SD** expansion anchor (page G12)

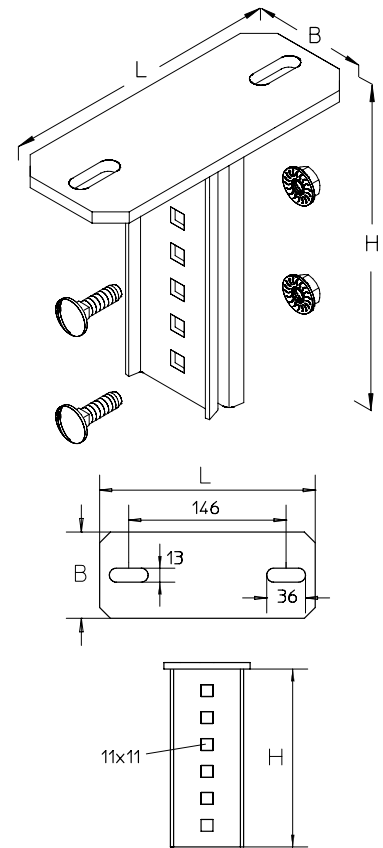

Support systems

KHI-system

BGID head plate, profile I80

For an application example, see the chapter assembly.



article number	H mm	B mm	L mm	G kg
F				
BGID F	200	80	200	2,30

accessories included:

- 2 x **FRS 10x30F** round-head screw with square, DIN 603 (page G35)
- 2 x **SES 10x30F** hexagon head bolt, DIN 933 (page G38)
- 4 x **SEM 10F** hexagon-nut, DIN 934 (page G41)

accessories optional:

- SD** expansion anchor (page G12)

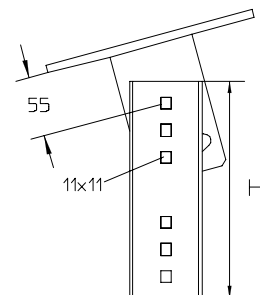
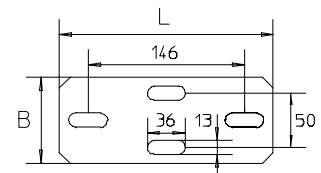
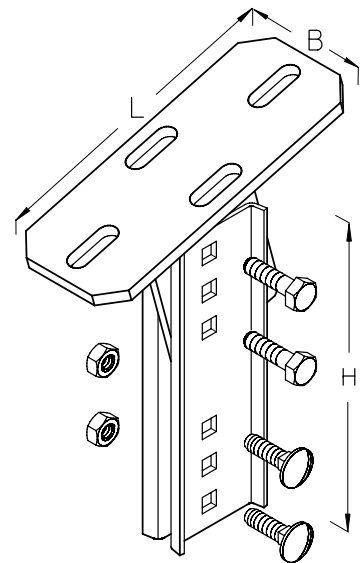

HKI support connector

For an application example, see the chapter assembly.

article number	L mm	G kg
F		
HKI F	200	1,00

accessories included:

- 4 x **FRS 10x30F** round-head screw with square, DIN 603 (page G35)
- 4 x **SEM 10F** hexagon-nut, DIN 934 (page G41)

accessories optional:

- SD** expansion anchor (page G12)

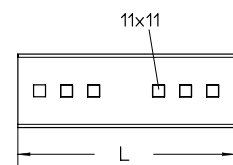
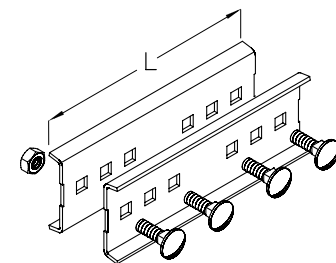

Support systems

KHI-system

HKIW support connector

For an application example, see the chapter assembly.

article number	G	kg
F		
HKIW F		1,00

accessories included:

- 3 x **FRS 12x30F** round-head screw with square, DIN 603 (page G35)
- 3 x **SEM 12F** hexagon-nut, DIN 934 (page G41)

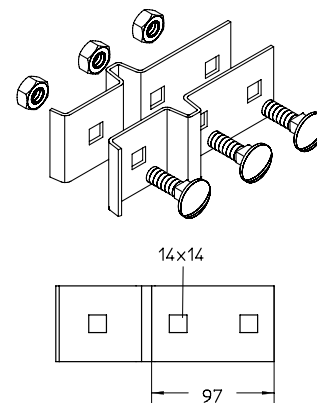

HKIQ support connector

For an application example, see the chapter assembly.

article number	G	kg
F		
HKIQ F		1,20

accessories included:

- 5 x **FRS 12x30F** round-head screw with square, DIN 603 (page G35)
- 5 x **SEM 12F** hexagon-nut, DIN 934 (page G41)
- 4 x **RUS 50-L13F** square washer (page G42)

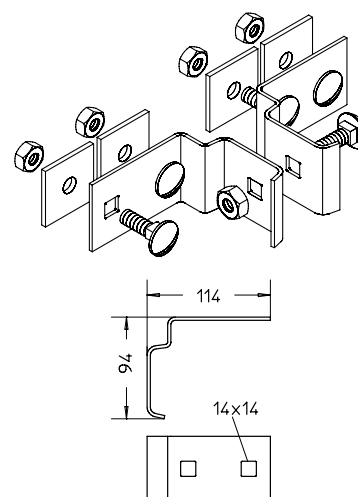

BL 3 corner angle

article number	H	B	t	G
	mm	mm	mm	kg
F				
BL 3F	40	90	6	0,20

accessories included:

- 1 x **FRS 12x30F** round-head screw with square, DIN 603 (page G35)
- 1 x **SEM 12F** hexagon-nut, DIN 934 (page G41)
- 1 x **RUS 50-L13F** square washer (page G42)

accessories optional:

- SD** expansion anchor (page G12)

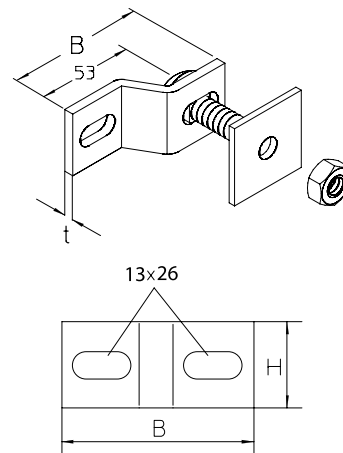

Support systems

KHI-system

BL 7 corner angle

article number	H mm	B mm	t mm	G kg
F				
BL 7F	50	65	5	0,30

accessories included:

1 x FRS 12x30F	round-head screw with square, DIN 603	(page G35)
1 x SEM 12F	hexagon-nut, DIN 934	(page G41)
1 x RUS 50-L13F	square washer	(page G42)

accessories optional:

SD	expansion anchor	(page G12)
-----------	------------------	------------

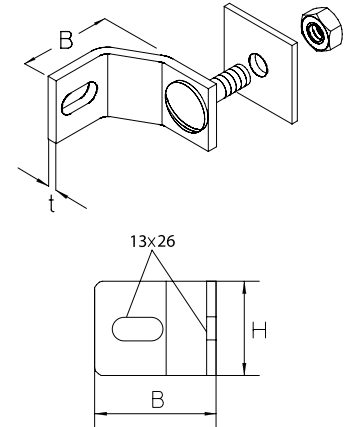

BL 8 corner angle

article number	H mm	B mm	t mm	G kg
F				
BL 8F	50	58	4	0,20

accessories included:

1 x FRS 10x30F	round-head screw with square, DIN 603	(page G35)
1 x SEM 10F	hexagon-nut, DIN 934	(page G41)
1 x RUS 50-L13F	square washer	(page G42)

accessories optional:

SD	expansion anchor	(page G12)
-----------	------------------	------------

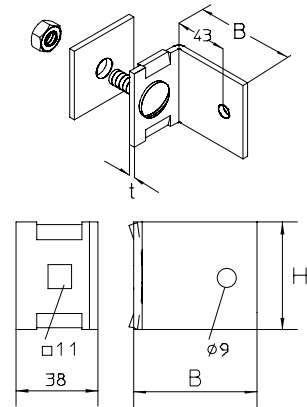

BLI corner angle

article number	H mm	t mm	G kg
F			
BLI F	140	6	0,80

accessories included:

1 x FRS 12x30F	round-head screw with square, DIN 603	(page G35)
1 x SEM 12F	hexagon-nut, DIN 934	(page G41)
1 x RUS 50-L13F	square washer	(page G42)

accessories optional:

SD	expansion anchor	(page G12)
-----------	------------------	------------

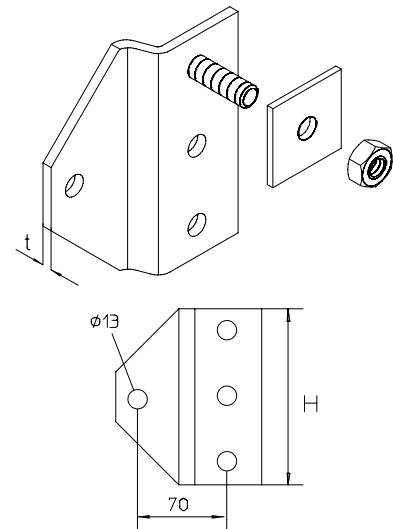

Support systems

KHI-system

SI protection end cap, yellow

article number	B mm	G kg
PE		
SI	80	0,02

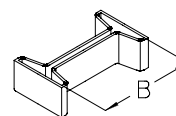

KZF cold zinc paint

For assembly instructions, see the chapter assembly.

article number	l ml	G kg
KZF	750	1,93

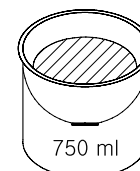

KZS cold zinc spray

For assembly instructions, see the chapter assembly.

article number	l ml	G kg
KZS	400	0,40

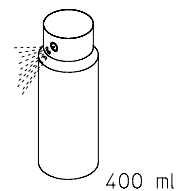

KDAG 41 ceiling fixed bracket, profile 41

F_D/P : coefficient for calculation of the dowel load F_D with effective bracket load P respectively the sum of effective bracket loads.

For an application example, see the chapter assembly.

For assembly instructions, see the chapter assembly.



article number	L mm	G kg
F		
KDAG 41-02F	200	1,10
KDAG 41-03F	300	1,40
KDAG 41-04F	400	1,70
KDAG 41-05F	500	1,90
KDAG 41-06F	600	2,20
KDAG 41-07F	700	2,50
KDAG 41-08F	800	2,70
KDAG 41-09F	900	3,00
KDAG 41-10F	1000	3,20

accessories optional:

KA 30	bracket, light duty, profile 41	(page F49)
KA 41	bracket, standard, profile 41	(page F49)
SD	expansion anchor	(page G12)
AM22	channel nut, A41/ KHA 41/ KHAL 41	(page G43)
AMF22	channel spring nut, A41	(page G43)
SA 2	protection end cap	(page F55)

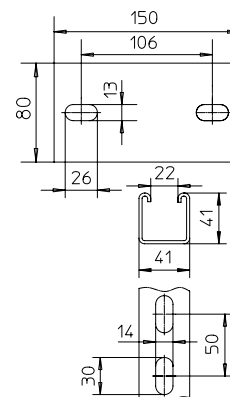
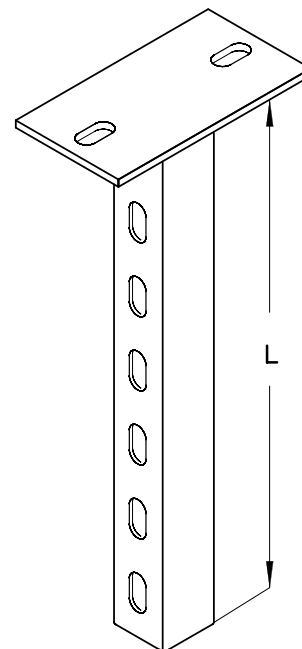

KHA 41 C-rail, perforated, 41x41 mm

This article is also available made in stainless steel finish, material No. 1.4571 / 1.4404 (V4A).
 For an application example, see the chapter assembly.
 For assembly instructions, see the chapter assembly.

article number	H mm	B mm	L mm	t mm	G kg
F					
KHA 41-01F	41	41	100	2,5	0,30
KHA 41-02F	41	41	200	2,5	0,50
KHA 41-03F	41	41	300	2,5	0,80
KHA 41-04F	41	41	400	2,5	1,10
KHA 41-05F	41	41	500	2,5	1,30
KHA 41-06F	41	41	600	2,5	1,60
KHA 41-07F	41	41	700	2,5	1,90
KHA 41-08F	41	41	800	2,5	2,10
KHA 41-09F	41	41	900	2,5	2,40
KHA 41-10F	41	41	1000	2,5	2,60
KHA 41-11F	41	41	1100	2,5	2,90
KHA 41-12F	41	41	1200	2,5	3,20
KHA 41-13F	41	41	1300	2,5	3,40
KHA 41-14F	41	41	1400	2,5	3,70
KHA 41-15F	41	41	1500	2,5	4,00
KHA 41-20F	41	41	2000	2,5	5,30
KHA 41-30F	41	41	3000	2,5	7,90
KHA 41-60F	41	41	6000	2,5	15,90

accessories optional:

AM22	channel nut, A41/ KHA 41/ KHAL 41	(page G43)
AMF22	channel spring nut, A41	(page G43)
RUS 41	stabilization plate, KHA profiles	(page G41)
SKS A	beam clamp set	(page G04)
SA 2	protection end cap	(page F55)
SAI 41	protection end cap	(page F55)

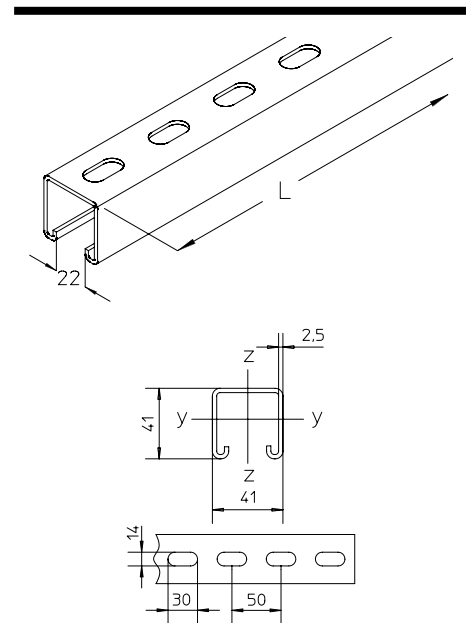

Support systems

KHA-system

KA 30 bracket, light duty, profile 41

For an application example, see the chapter assembly.

article number	B mm	L mm	P _{max} kN	G kg
F				
KA 30-010F	100	125	0,5	0,20
KA 30-015F	150	175	0,5	0,30
KA 30-020F	200	225	0,5	0,30
KA 30-025F	250	275	0,5	0,40
KA 30-030F	300	325	0,5	0,40
KA 30-040F	400	425	0,5	0,50

accessories optional:

HS16	Tee-head bolt	(page G46)
AM16	channel nut, B7	(page G45)
KLR	fixing set	(page G33)

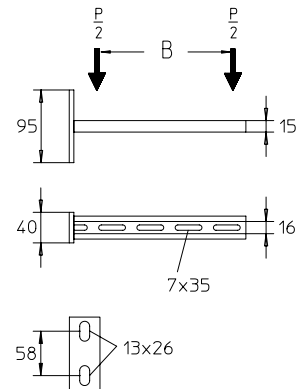
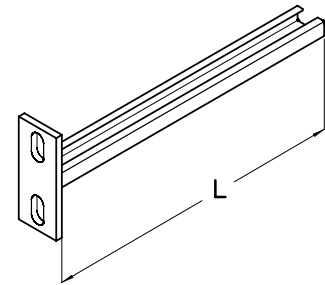

KA 41 bracket, standard, profile 41

For an application example, see the chapter assembly.

article number	B mm	L mm	P _{max} kN	G kg
F				
KA 41-010F	100	125	3,7	1,00
KA 41-015F	150	175	3,7	1,10
KA 41-020F	200	225	3,7	1,20
KA 41-025F	250	275	3,7	1,40
KA 41-030F	300	325	3,7	1,50
KA 41-040F	400	425	3,7	1,60
KA 41-050F	500	525	3,7	1,80
KA 41-060F	600	625	3,7	1,90

accessories optional:

AM22	channel nut, A41/ KHA 41/ KHAL 41	(page G43)
AMF22	channel spring nut, A41	(page G43)
SES	hexagon head bolt, DIN 933	(page G37)

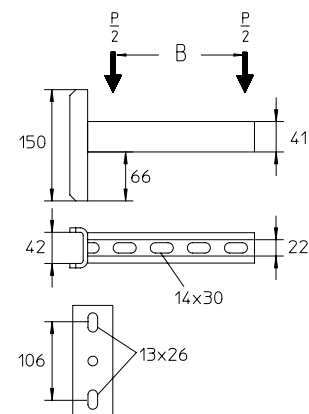
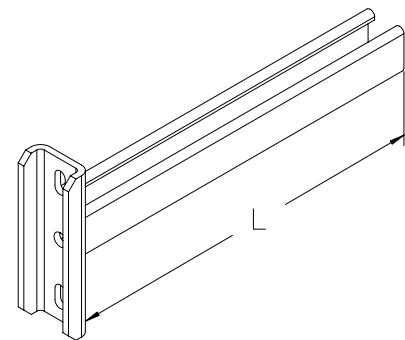

Support systems

KHA-system

BGA 41 Mounting/ floor/ ceiling plate

For an application example, see the chapter assembly.
For assembly instructions, see the chapter assembly.

article number	H mm	B mm	L mm	G kg
F				
BGA 41F	120	80	200	1,20

accessories optional:

SD	expansion anchor	(page G12)
SKL M	beam clamp set	(page G06)
SES	hexagon head bolt, DIN 933	(page G37)
AMF22	channel spring nut, A41	(page G43)
AM22	channel nut, A41/ KHA 41/ KHAL 41	(page G43)

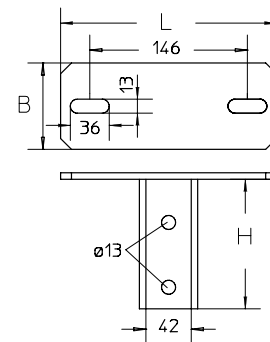
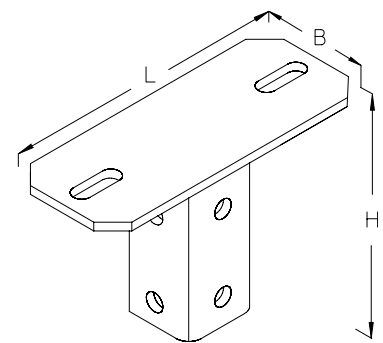

BGA 41/2 head plate, profile 41

For an application example, see the chapter assembly.

article number	H mm	B mm	L mm	G kg
F				
BGA 41/2F	120	80	220	1,80

accessories optional:

SD	expansion anchor	(page G12)
SKL M	beam clamp set	(page G06)
SES	hexagon head bolt, DIN 933	(page G37)
AMF22	channel spring nut, A41	(page G43)
AM22	channel nut, A41/ KHA 41/ KHAL 41	(page G43)

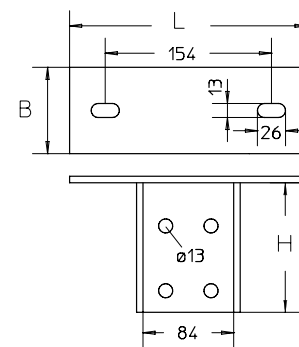
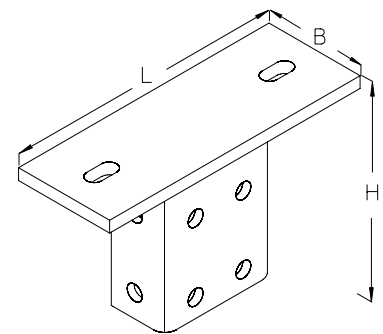

Support systems

KHA-system

AV coupler for KHA-profile

For an application example, see the chapter assembly.

article number	H mm	B mm	L mm	t mm	G kg
F					
AV 41F	42	40	200	4	0,70

accessories optional:

AMF22	channel spring nut, A41	(page G43)
AM22	channel nut, A41/ KHA 41/ KHAL 41	(page G43)
US 125	square washer, DIN 125	(page G39)
IK	hexagon socket head screw, DIN 912	(page G36)
SEM	hexagon-nut, DIN 934	(page G41)

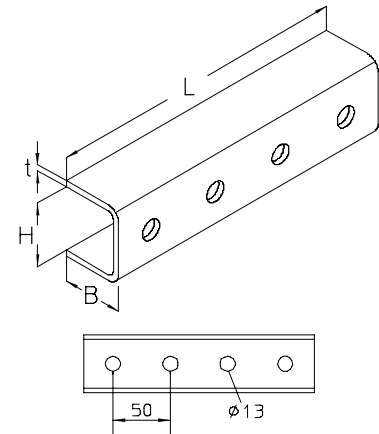

BL 5 corner angle

article number	H mm	B mm	L mm	t mm	G kg
F					
BL 5F	40	45	60	6	0,20

accessories optional:

SD	expansion anchor	(page G12)
SES	hexagon head bolt, DIN 933	(page G37)
AM22	channel nut, A41/ KHA 41/ KHAL 41	(page G43)
AMF22	channel spring nut, A41	(page G43)
HS18	tee-head bolt, A7/ A8/ A9	(page G45)
AMF18	channel spring nut, A7/ A8	(page G45)
AM18	channel nut, A7/ A8	(page G44)

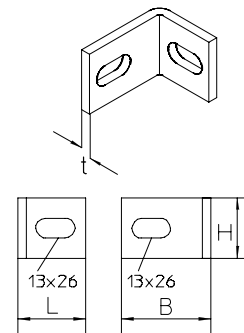

AKL rail clamp

For an application example, see the chapter assembly.

article number	H mm	t mm	G kg
F			
AKL 41F	84	6	0,30

accessories optional:

SES	hexagon head bolt, DIN 933	(page G37)
AM22	channel nut, A41/ KHA 41/ KHAL 41	(page G43)
AMF22	channel spring nut, A41	(page G43)

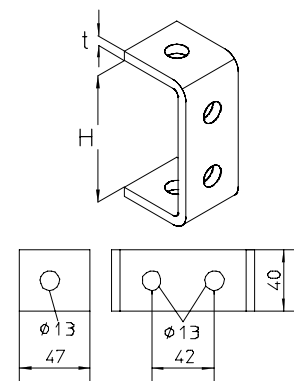

Support systems

KHA-system

AVL fastening strip

For an application example, see the chapter assembly.

article number	B mm	L mm	t mm	G kg
F				
AVL-1F	40	42	6	0,07
AVL-2F	40	89	6	0,16
AVL-3F	40	136	6	0,24
AVL-4F	40	183	6	0,32
AVL-5F	40	230	6	0,40

accessories optional:

SES	hexagon head bolt, DIN 933	(page G37)
AM22	channel nut, A41/ KHA 41/ KHAL 41	(page G43)
AMF22	channel spring nut, A41	(page G43)

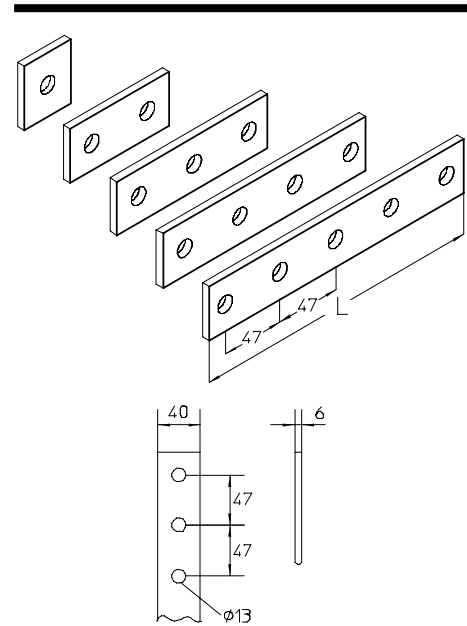

AVE corner connector 90°

For an application example, see the chapter assembly.

article number	B mm	L mm	t mm	G kg
F				
AVE F	90	90	6	0,27

accessories optional:

SES	hexagon head bolt, DIN 933	(page G37)
AM22	channel nut, A41/ KHA 41/ KHAL 41	(page G43)
AMF22	channel spring nut, A41	(page G43)

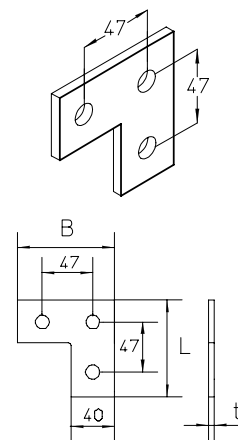

Support systems

KHA-system

AVA corner connector T-piece

For an application example, see the chapter assembly.

article number	B mm	L mm	t mm	G kg
F				
AVA F	136	90	6	0,36

accessories optional:

SES	hexagon head bolt, DIN 933	(page G37)
AM22	channel nut, A41/ KHA 41/ KHAL 41	(page G43)
AMF22	channel spring nut, A41	(page G43)

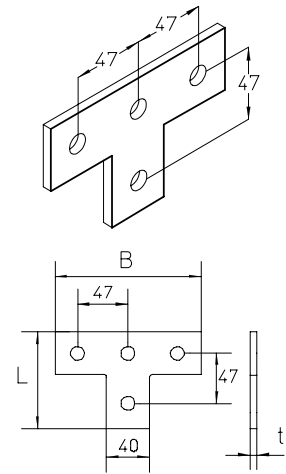

AVB rail coupler U support

For an application example, see the chapter assembly.

article number	H mm	t mm	G kg
F			
AVB 41F	40	6	0,44
AVB 41/2F	40	6	0,48

accessories optional:

SES	hexagon head bolt, DIN 933	(page G37)
AM22	channel nut, A41/ KHA 41/ KHAL 41	(page G43)
AMF22	channel spring nut, A41	(page G43)

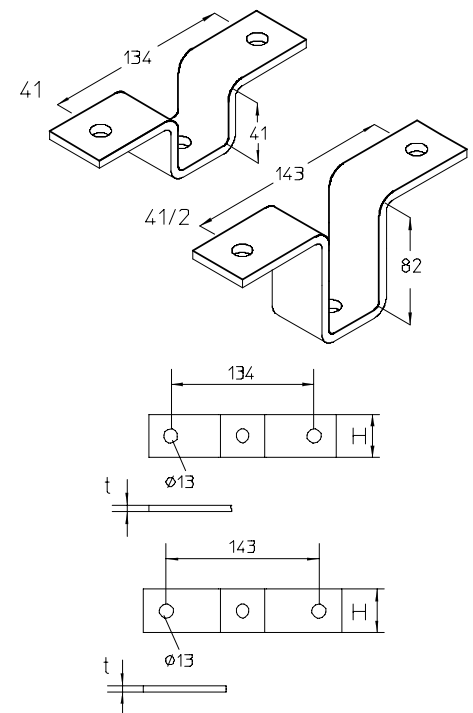

Support systems

KHA-system

AVLW corner connector 90°

For an application example, see the chapter assembly.

article number	H mm	B mm	L mm	t mm	G kg
F					
AVLW 1-1F	40	42	58	6	0,17
AVLW 1-2F	40	42	106	6	0,26
AVLW 1-3F	40	58	136	6	0,36
AVLW 2-2F	40	89	106	6	0,44

accessories optional:

SES	hexagon head bolt, DIN 933	(page G37)
AM22	channel nut, A41/ KHA 41/ KHAL 41	(page G43)
AMF22	channel spring nut, A41	(page G43)

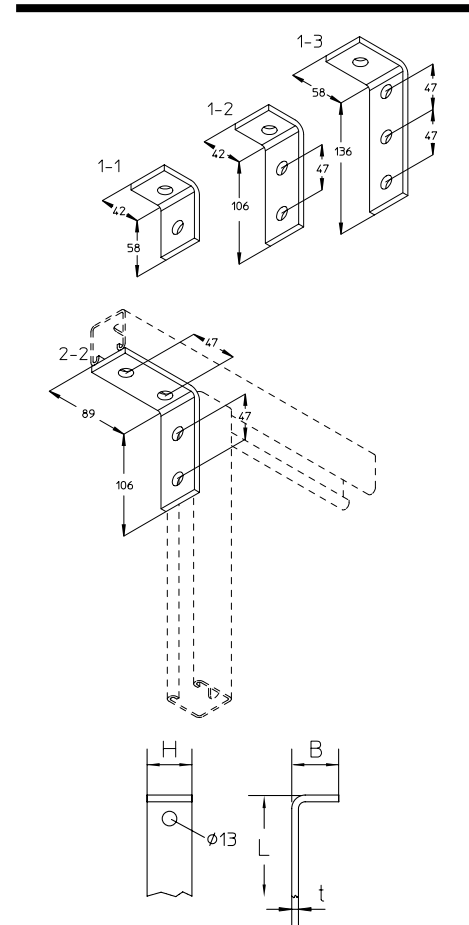

AVAW corner connector left / center / right

For an application example, see the chapter assembly.

article number	H mm	B mm	L mm	t mm	G kg
F					
AVAW-L F	90	98	48	6	0,36
AVAW-M F	51	136	52	6	0,36
AVAW-R F	90	98	48	6	0,36

accessories optional:

SES	hexagon head bolt, DIN 933	(page G37)
AM22	channel nut, A41/ KHA 41/ KHAL 41	(page G43)
AMF22	channel spring nut, A41	(page G43)

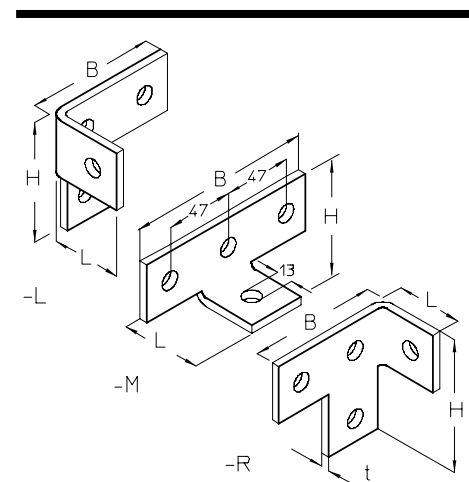

SA 1 protection end cap

article number	G kg
PE	
SA 1	0,01



Support systems

KHA-system

SA 2 protection end cap

article number	G	kg
PE		
SA 2		0,01

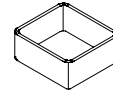

SAI 41 protection end cap

article number	colour	G	kg
PE			
SAI 41-S	black	0,01	
SAI 41-W	white	0,01	

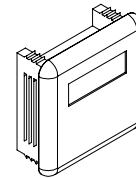

SAI 21 protection end cap

article number	colour	G	kg
PE			
SAI 21-S	black	0,01	
SAI 21-W	white	0,01	

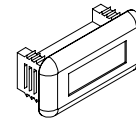

F

Support systems

Profile rails

ASK 4 coupler for KHA-profile

For an application example, see the chapter assembly.

article number	H mm	B mm	L mm	t mm	G kg
F					
ASK 4	49	24	200	2	0,31

accessories included:

- 4 x **FRS 8x20E** round-head screw with square, DIN 603 (page G35)
- 4 x **SEMS 8E** hexagon nut, self-locking, DIN 6923 (page G41)

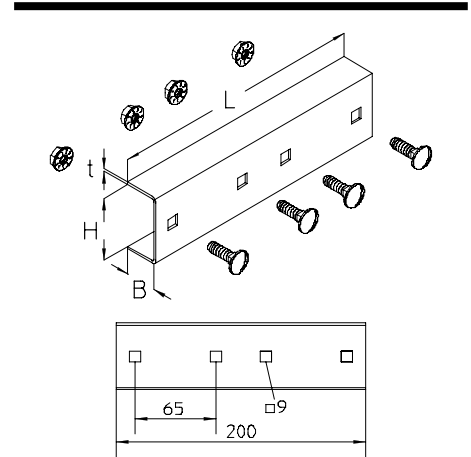

ASK 8 coupler for KHA-profile

For an application example, see the chapter assembly.

article number	H mm	B mm	L mm	t mm	G kg
F					
ASK 8	41	19	200	2	0,25

accessories included:

- 4 x **FRS 8x20E** round-head screw with square, DIN 603 (page G35)
- 4 x **SEMS 8E** hexagon nut, self-locking, DIN 6923 (page G41)

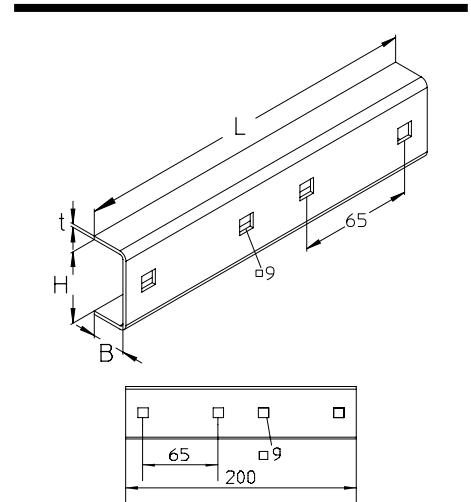

A 2 C-rail, not perforated, 50x31 mm

article number	H mm	B mm	L mm	t mm	G kg
B					
A 2-30B	31	50	3000	3,25	8,80
A 2-60B	31	50	6000	3,25	17,60
F					
A 2-30F	31	50	3000	3,25	9,40
A 2-60F	31	50	6000	3,25	18,80

accessories optional:

- HS22** tee-head bolt, A2/ A4 (page G43)
- SKS H** beam clamp set (page G03)

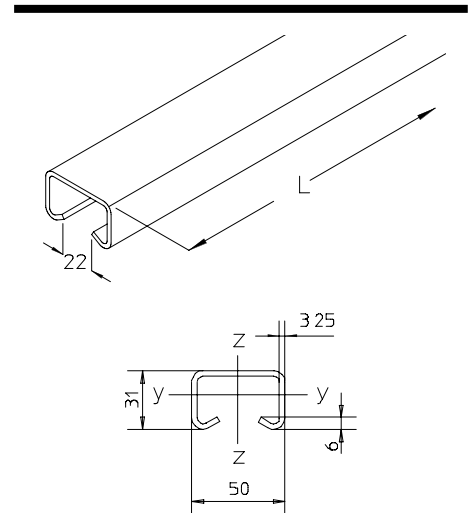

Support systems

Profile rails

KHA 2 C-rail, perforated, 50x31 mm

For an application example, see the chapter assembly.

article number	H mm	B mm	L mm	t mm	G kg
F					
KHA 2-05F	31	50	500	3,25	1,50
KHA 2-10F	31	50	1000	3,25	3,00
KHA 2-15F	31	50	1500	3,25	4,50
KHA 2-20F	31	50	2000	3,25	6,00
KHA 2-30F	31	50	3000	3,25	9,00
KHA 2-60F	31	50	6000	3,25	17,90

accessories optional:

HS22 tee-head bolt, A2/ A4 (page G43)
SKS H beam clamp set (page G03)

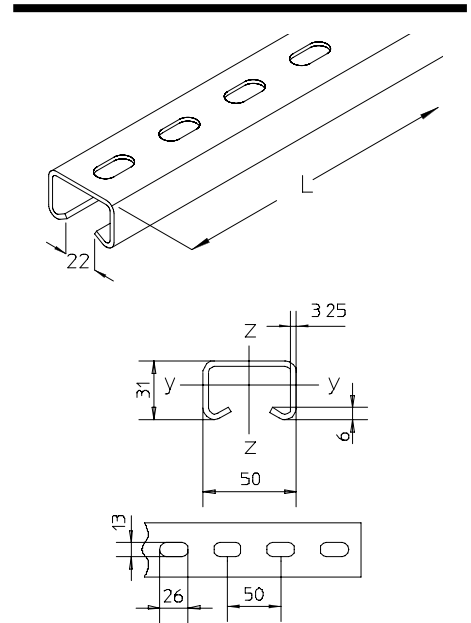

A 4 C-rail, not perforated, 48x26 mm

article number	H mm	B mm	L mm	t mm	G kg
B					
A 4-30B	26	48	3000	2,5	6,70
A 4-60B	26	48	6000	2,5	13,40
F					
A 4-30F	26	48	3000	2,5	7,20
A 4-60F	26	48	6000	2,5	14,40

accessories optional:

HS22 tee-head bolt, A2/ A4 (page G43)

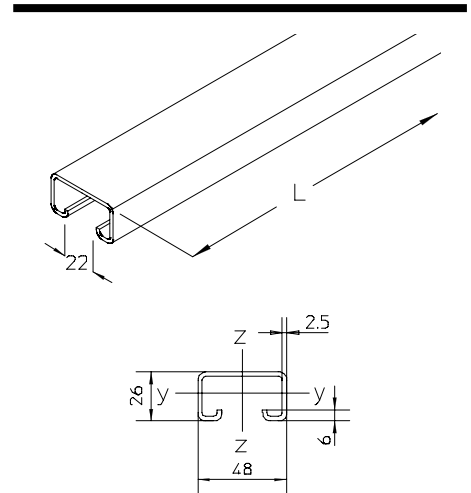

F

Support systems

Profile rails

KHA 4 C-rail, perforated, 48x26 mm

article number	H mm	B mm	L mm	t mm	G kg
F					
KHA 4-30F	26	48	3000	2,5	6,80
KHA 4-60F	26	48	6000	2,5	13,60

accessories optional:

HS22 tee-head bolt, A2/ A4 (page G43)

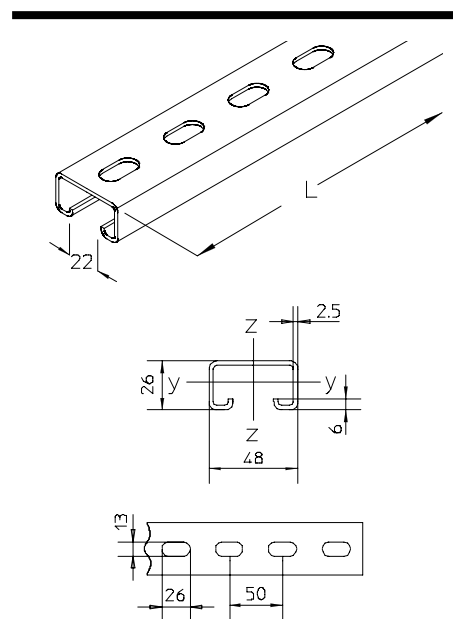

A 7 C-rail, not perforated, 40x22 mm

article number	H mm	B mm	L mm	t mm	G kg
S					
A 7-30S	22	39,5	3000	1,5	3,90
A 7-60S	22	39,5	6000	1,5	7,80
E					
A 7-30E	22	39,5	3000	1,5	3,60
A 7-60E	22	39,5	6000	1,5	7,20

accessories optional:

HS18 tee-head bolt, A7/ A8/ A9 (page G45)

AM18 channel nut, A7/ A8 (page G44)

AMF18 channel spring nut, A7/ A8 (page G45)

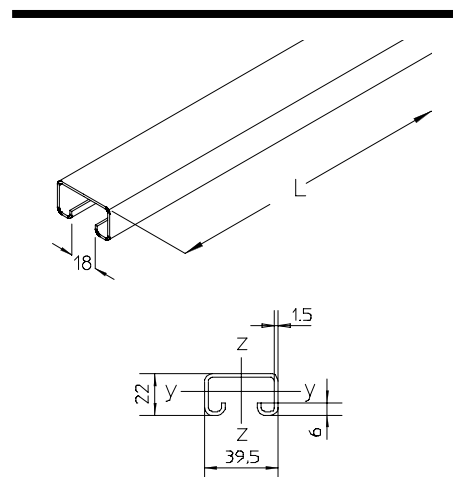

Support systems

Profile rails

KHA 7 C-rail, perforated, 40x22 mm

This article is also available made in stainless steel finish, material No. 1.4571 / 1.4404 (V4A).

article number	H mm	B mm	L mm	t mm	G kg
S					
KHA 7-02S	22	39,5	200	1,5	0,20
KHA 7-03S	22	39,5	300	1,5	0,30
KHA 7-04S	22	39,5	400	1,5	0,40
KHA 7-05S	22	39,5	500	1,5	0,50
KHA 7-06S	22	39,5	600	1,5	0,60
KHA 7-07S	22	39,5	700	1,5	0,70
KHA 7-08S	22	39,5	800	1,5	0,80
KHA 7-09S	22	39,5	900	1,5	1,00
KHA 7-10S	22	39,5	1000	1,5	1,10
KHA 7-11S	22	39,5	1100	1,5	1,20
KHA 7-12S	22	39,5	1200	1,5	1,30
KHA 7-13S	22	39,5	1300	1,5	1,40
KHA 7-14S	22	39,5	1400	1,5	1,50
KHA 7-15S	22	39,5	1500	1,5	1,60
KHA 7-20S	22	39,5	2000	1,5	2,20
KHA 7-30S	22	39,5	3000	1,5	3,20
KHA 7-60S	22	39,5	6000	1,5	6,30

E					
KHA 7-01E	22	39,5	100	1,5	0,10
KHA 7-02E	22	39,5	200	1,5	0,20
KHA 7-03E	22	39,5	300	1,5	0,30
KHA 7-04E	22	39,5	400	1,5	0,40
KHA 7-05E	22	39,5	500	1,5	0,60
KHA 7-06E	22	39,5	600	1,5	0,70
KHA 7-07E	22	39,5	700	1,5	0,80
KHA 7-08E	22	39,5	800	1,5	0,90
KHA 7-09E	22	39,5	900	1,5	1,00
KHA 7-10E	22	39,5	1000	1,5	1,10
KHA 7-11E	22	39,5	1100	1,5	1,20
KHA 7-12E	22	39,5	1200	1,5	1,30
KHA 7-13E	22	39,5	1300	1,5	1,50
KHA 7-14E	22	39,5	1400	1,5	1,60
KHA 7-15E	22	39,5	1500	1,5	1,70
KHA 7-20E	22	39,5	2000	1,5	2,20
KHA 7-30E	22	39,5	3000	1,5	3,40
KHA 7-60E	22	39,5	6000	1,5	6,70

accessories optional:

HS18	tee-head bolt, A7/ A8/ A9	(page G45)
AM18	channel nut, A7/ A8	(page G44)
AMF18	channel spring nut, A7/ A8	(page G45)
ASK 8	coupler for KHA-profile	(page F56)
SA 1	protection end cap	(page F54)

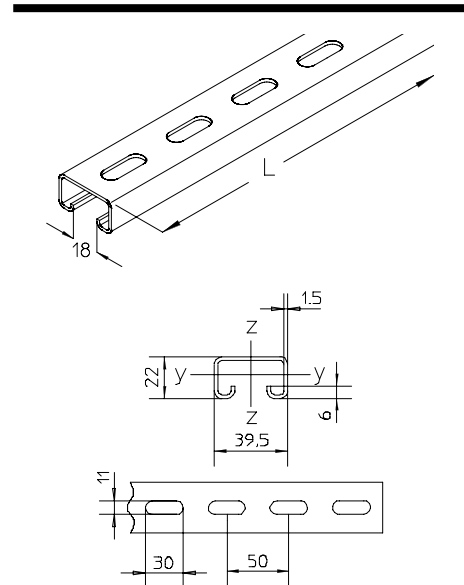

F

Support systems

Profile rails

A 8 C-rail, not perforated, 40x22 mm

article number	H mm	B mm	L mm	t mm	G kg
B					
A 8-30B	22	40	3000	2	4,60
A 8-60B	22	40	6000	2	9,20
F					
A 8-30F	22	40	3000	2	5,00
A 8-60F	22	40	6000	2	9,90

accessories optional:

HS18	tee-head bolt, A7/ A8/ A9	(page G45)
AM18	channel nut, A7/ A8	(page G44)
AMF18	channel spring nut, A7/ A8	(page G45)

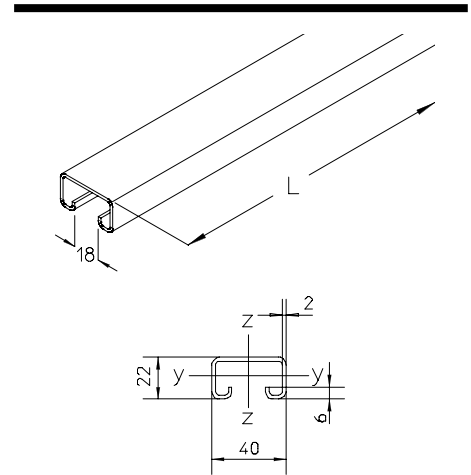

KHA 8 C-rail, perforated, 40x22 mm

For an application example, see the chapter assembly.

article number	H mm	B mm	L mm	t mm	G kg
F					
KHA 8-01F	22	40	100	2	0,20
KHA 8-02F	22	40	200	2	0,30
KHA 8-03F	22	40	300	2	0,50
KHA 8-04F	22	40	400	2	0,60
KHA 8-05F	22	40	500	2	0,80
KHA 8-06F	22	40	600	2	0,90
KHA 8-07F	22	40	700	2	1,10
KHA 8-08F	22	40	800	2	1,30
KHA 8-09F	22	40	900	2	1,40
KHA 8-10F	22	40	1000	2	1,60
KHA 8-11F	22	40	1100	2	1,70
KHA 8-12F	22	40	1200	2	1,90
KHA 8-13F	22	40	1300	2	2,00
KHA 8-14F	22	40	1400	2	2,20
KHA 8-15F	22	40	1500	2	2,40
KHA 8-20F	22	40	2000	2	3,10
KHA 8-30F	22	40	3000	2	4,70
KHA 8-60F	22	40	6000	2	9,40

accessories optional:

HS18	tee-head bolt, A7/ A8/ A9	(page G45)
AM18	channel nut, A7/ A8	(page G44)
AMF18	channel spring nut, A7/ A8	(page G45)
ASK 8	coupler for KHA-profile	(page F56)

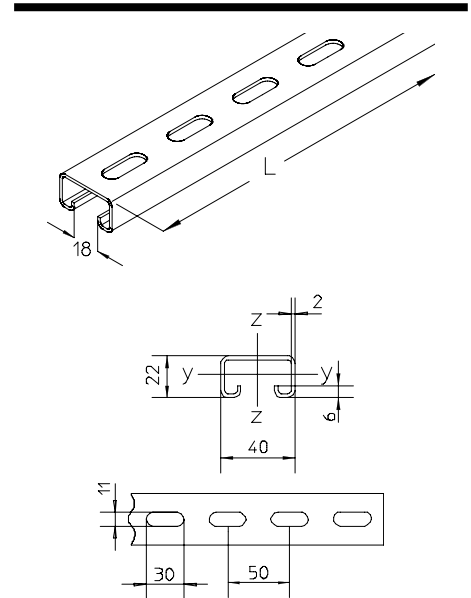

Support systems

Profile rails

A 9 C-rail, not perforated, 40x25 mm

article number	H mm	B mm	L mm	t mm	G kg
B					
A 9-30B	25	39,5	3000	2,75	5,50
A 9-60B	25	39,5	6000	2,75	11,00
F					
A 9-30F	25	39,5	3000	2,75	5,90
A 9-60F	25	39,5	6000	2,75	11,80

accessories optional:

HS18 tee-head bolt, A7/ A8/ A9 (page G45)

AMA18 channel nut, A7/ A8 (page G44)

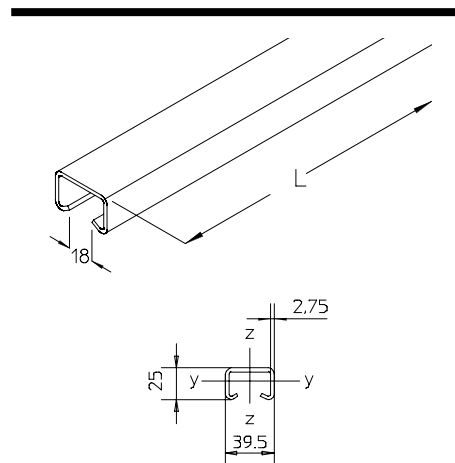

KHA 9 C-rail, perforated, 40x25 mm

article number	H mm	B mm	L mm	t mm	G kg
F					
KHA 9-02F	25	39,5	200	2,75	0,40
KHA 9-03F	25	39,5	300	2,75	0,60
KHA 9-04F	25	39,5	400	2,75	0,80
KHA 9-05F	25	39,5	500	2,75	0,90
KHA 9-06F	25	39,5	600	2,75	1,20
KHA 9-07F	25	39,5	700	2,75	1,40
KHA 9-08F	25	39,5	800	2,75	1,60
KHA 9-09F	25	39,5	900	2,75	1,80
KHA 9-10F	25	39,5	1000	2,75	1,90
KHA 9-11F	25	39,5	1100	2,75	2,10
KHA 9-12F	25	39,5	1200	2,75	2,30
KHA 9-13F	25	39,5	1300	2,75	2,40
KHA 9-14F	25	39,5	1400	2,75	2,60
KHA 9-15F	25	39,5	1500	2,75	2,80
KHA 9-20F	25	39,5	2000	2,75	3,70
KHA 9-30F	25	39,5	3000	2,75	5,60
KHA 9-60F	25	39,5	6000	2,75	11,20

accessories optional:

AMA18 channel nut, A7/ A8 (page G44)

HS18 tee-head bolt, A7/ A8/ A9 (page G45)

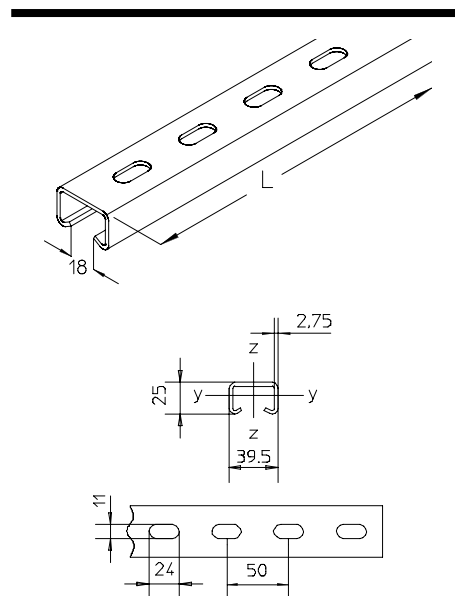

Support systems

Profile rails

KHA 21 C-rail, perforated, 41x21 mm

article number	H mm	B mm	L mm	t mm	G kg
F					
KHA 21-30F	21	41	3000	2,5	5,30
KHA 21-60F	21	41	6000	2,5	10,60
E4					
KHA 21-30E4	21	41	3000	2,5	5,10
KHA 21-60E4	21	41	6000	2,5	10,10

accessories optional:

AM22	channel nut, A41/ KHA 41/ KHAL 41	(page G43)
RUS 41	stabilization plate, KHA profiles	(page G41)
SA 1	protection end cap	(page F54)
SAI 21	protection end cap	(page F55)

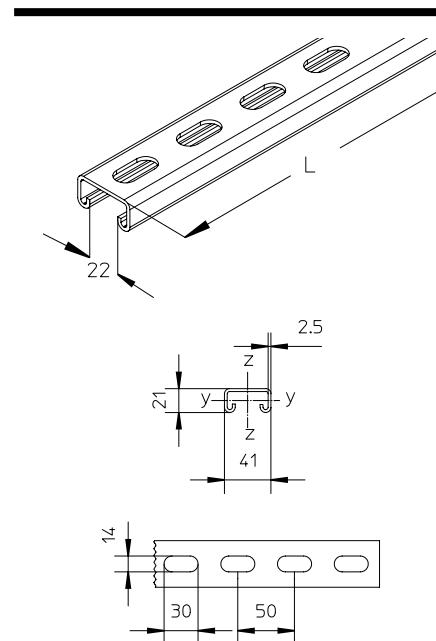

A 41 C-rail, not perforated, 41x41 mm

article number	H mm	B mm	L mm	t mm	G kg
B					
A 41-30B	41	41	3000	2,5	7,80
A 41-60B	41	41	6000	2,5	15,60
F					
A 41-30F	41	41	3000	2,5	8,30
A 41-60F	41	41	6000	2,5	16,60

accessories optional:

AM22	channel nut, A41/ KHA 41/ KHAL 41	(page G43)
AMF22	channel spring nut, A41	(page G43)

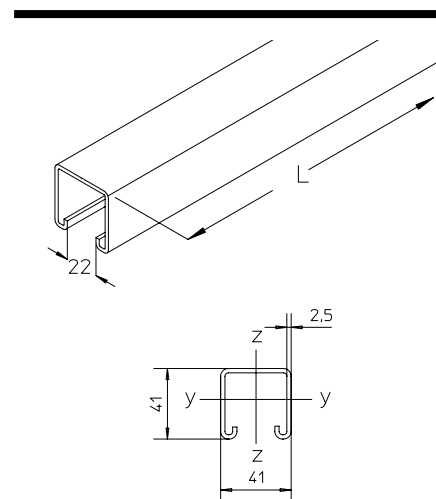

Support systems

Profile rails

KHA 41 C-rail, perforated, 41x41 mm

This article is also available made in stainless steel finish, material No. 1.4571 / 1.4404 (V4A).
For an application example, see the chapter assembly.
For assembly instructions, see the chapter assembly.

article number	H mm	B mm	L mm	t mm	G kg
F					
KHA 41-01F	41	41	100	2,5	0,30
KHA 41-02F	41	41	200	2,5	0,50
KHA 41-03F	41	41	300	2,5	0,80
KHA 41-04F	41	41	400	2,5	1,10
KHA 41-05F	41	41	500	2,5	1,30
KHA 41-06F	41	41	600	2,5	1,60
KHA 41-07F	41	41	700	2,5	1,90
KHA 41-08F	41	41	800	2,5	2,10
KHA 41-09F	41	41	900	2,5	2,40
KHA 41-10F	41	41	1000	2,5	2,60
KHA 41-11F	41	41	1100	2,5	2,90
KHA 41-12F	41	41	1200	2,5	3,20
KHA 41-13F	41	41	1300	2,5	3,40
KHA 41-14F	41	41	1400	2,5	3,70
KHA 41-15F	41	41	1500	2,5	4,00
KHA 41-20F	41	41	2000	2,5	5,30
KHA 41-30F	41	41	3000	2,5	7,90
KHA 41-60F	41	41	6000	2,5	15,90

accessories optional:

AM22	channel nut, A41/ KHA 41/ KHAL 41	(page G43)
AMF22	channel spring nut, A41	(page G43)
RUS 41	stabilization plate, KHA profiles	(page G41)
SKS A	beam clamp set	(page G04)
SA 2	protection end cap	(page F55)
SAI 41	protection end cap	(page F55)

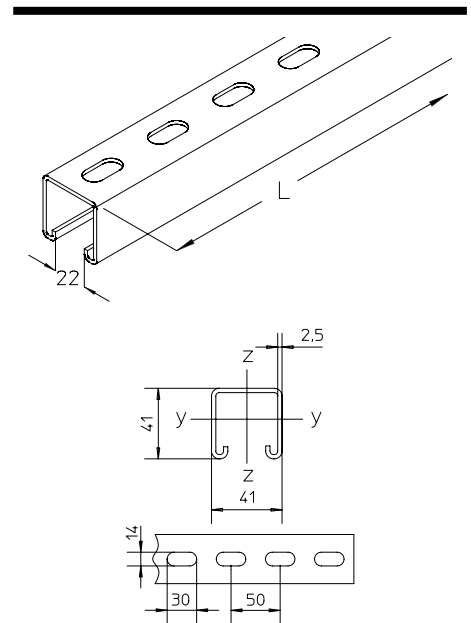

F

Support systems

Profile rails

KHAL 41 C-rail, perforated, 41x41 mm

For an application example, see the chapter assembly.

article number	H mm	B mm	L mm	t mm	G kg
S					
KHAL 41-30S	41	41	3000	1,5	4,70
KHAL 41-60S	41	41	6000	1,5	9,40
F					
KHAL 41-05F	41	41	500	1,5	0,80
KHAL 41-10F	41	41	1000	1,5	1,70
KHAL 41-15F	41	41	1500	1,5	2,50
KHAL 41-20F	41	41	2000	1,5	3,30
KHAL 41-30F	41	41	3000	1,5	5,00
KHAL 41-36F	41	41	3600	1,5	6,01
KHAL 41-60F	41	41	6000	1,5	10,00

accessories optional:

AM22 channel nut, A41/ KHA 41/ KHAL 41 (page G43)
AMF22 channel spring nut, A41 (page G43)

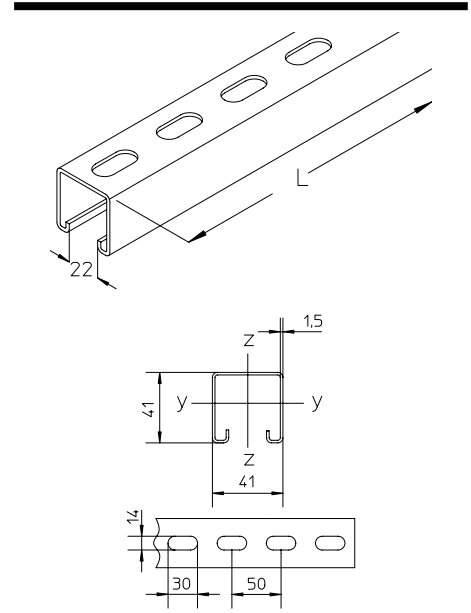

KHA 82 C-rail, perforated, 41x82 mm

This article is also available made in stainless steel finish, material No. 1.4571 / 1.4404 (V4A).

article number	H mm	B mm	L mm	t mm	G kg
F					
KHA 82-60F	82	41	6000	2,5	31,80

accessories optional:

AM22 channel nut, A41/ KHA 41/ KHAL 41 (page G43)
AMF22 channel spring nut, A41 (page G43)
RUS 41 stabilization plate, KHA profiles (page G41)

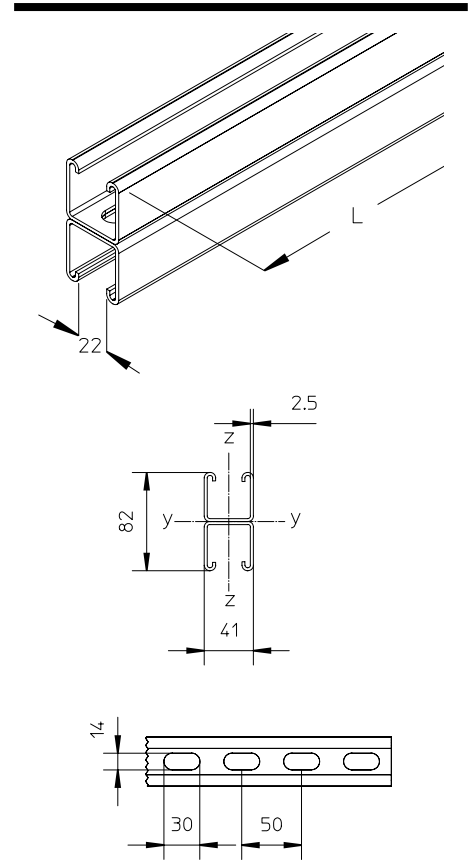

Support systems

Profile rails

KHA 42 C-rail, perforated, 41x42 mm

This article is also available made in stainless steel finish, material No. 1.4571 / 1.4404 (V4A).

article number	H mm	B mm	L mm	t mm	G kg
F					
KHA 42-60F	42	41	6000	2,5	20,70

accessories optional:

AM22 channel nut, A41/ KHA 41/ KHAL 41 (page G43)
RUS 41 stabilization plate, KHA profiles (page G41)

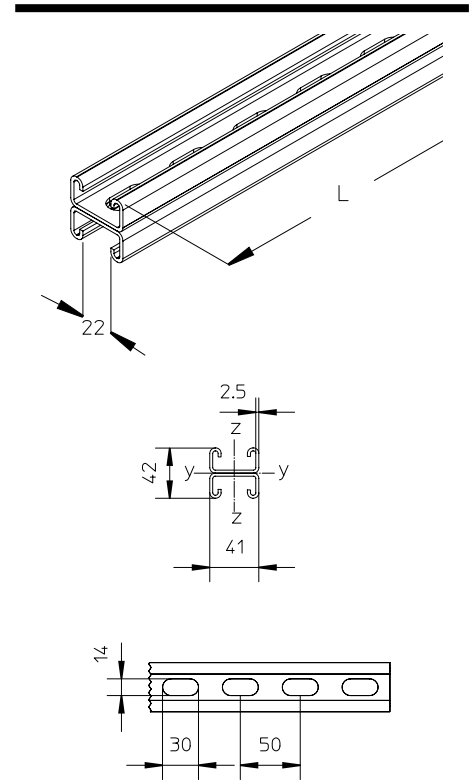

B 3 profile rail, not perforated, 28x12 mm

article number	H mm	B mm	L mm	t mm	G kg
B					
B 3-30B	12	28	3000	2	2,50
B 3-60B	12	28	6000	2	5,00
F					
B 3-30F	12	28	3000	2	2,70
B 3-60F	12	28	6000	2	5,30
E4					
B 3-30E4	12	28	3000	2	2,50
B 3-60E4	12	28	6000	2	5,00

accessories optional:

HS12 Tee-head bolt (page G46)
AM12 channel nut, B3/ B6 (page G46)

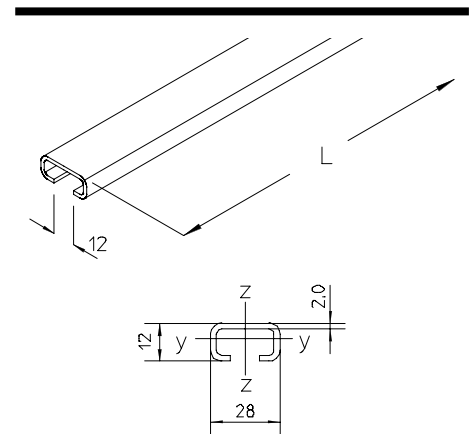

Support systems

Profile rails

B 6 profile rail, not perforated, 28x15 mm

article number	H mm	B mm	L mm	t mm	G kg
B					
B 6-30B	15	28	3000	2,3	3,10
B 6-60B	15	28	6000	2,3	6,30
F					
B 6-30F	15	28	3000	2,3	3,40
B 6-60F	15	28	6000	2,3	6,70
E					
B 6-30E	15	28	3000	2,3	3,10
B 6-60E	15	28	6000	2,3	6,30
E4					
B 6-30E4	15	28	3000	2,3	3,40
B 6-60E4	15	28	6000	2,3	6,30

accessories optional:

HS12 Tee-head bolt (page G46)

AM12 channel nut, B3/ B6 (page G46)

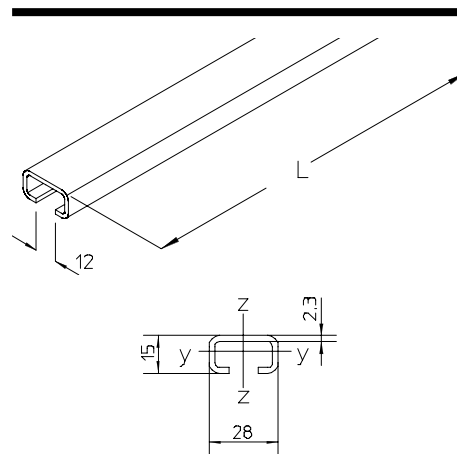

B 7 profile rail, not perforated, 30x15 mm

article number	H mm	B mm	L mm	t mm	G kg
B					
B 7-30B	15	30	3000	1,5	2,20
B 7-60B	15	30	6000	1,5	4,40
S					
B 7-30S	15	30	3000	1,5	2,30
B 7-60S	15	30	6000	1,5	4,50
F					
B 7-30F	15	30	3000	1,5	2,40
B 7-60F	15	30	6000	1,5	4,80
E					
B 7-30E	15	30	3000	1,5	2,20
B 7-60E	15	30	6000	1,5	4,40

accessories optional:

HS16 Tee-head bolt (page G46)

AM16 channel nut, B7 (page G45)

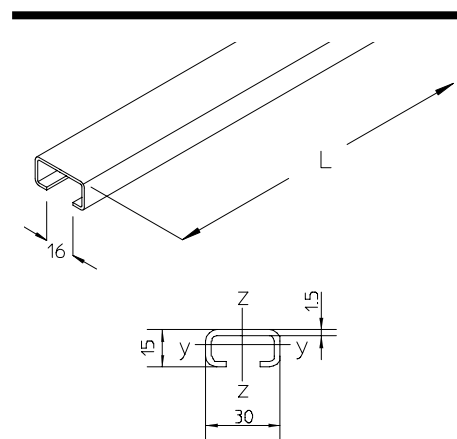

Support systems

Profile rails

KHB 7 profile rail, perforated, 30x15 mm

This article is also available made in stainless steel finish, material No. 1.4571 / 1.4404 (V4A).

article number	H mm	B mm	L mm	t mm	G kg
S					
KHB 7-30S	15	30	3000	1,5	2,10
KHB 7-60S	15	30	6000	1,5	4,20
F					
KHB 7-30F	15	30	3000	1,5	2,30
KHB 7-60F	15	30	6000	1,5	4,60
E					
KHB 7-20E	15	30	2000	1,5	1,34
KHB 7-30E	15	30	3000	1,5	2,20
KHB 7-60E	15	30	6000	1,5	4,40

accessories optional:

HS16 Tee-head bolt (page G46)
AM16 channel nut, B7 (page G45)

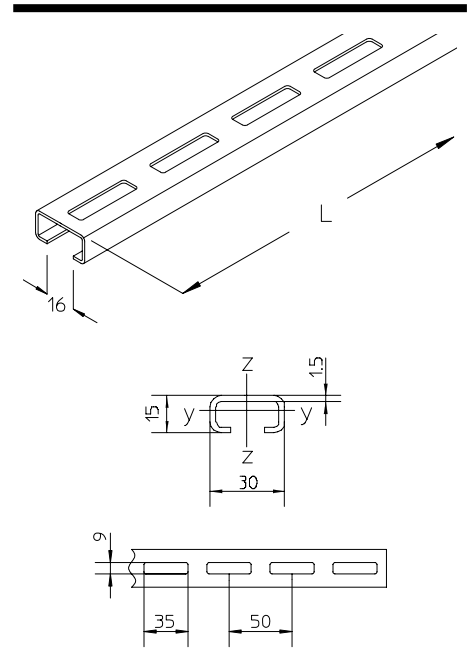

PRS cut

For detailed explanations, see the chapter planning.

article number
PRS A
PRS B

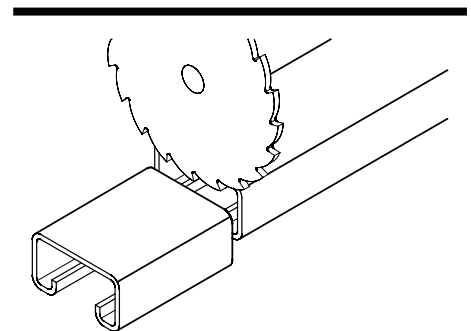

RL round hole

For detailed explanations, see the chapter planning.

article number	D mm
RL 7	7
RL 9	9
RL 11	11
RL 13	13

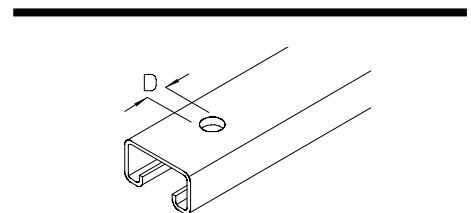

Support systems

Profile rails

LGL elongated hole

For detailed explanations, see the chapter planning.

article number	B mm	L mm
LGL 7x10	7	10
LGL 9x20	9	20
LGL 11x24	11	24
LGL 13x26	13	26

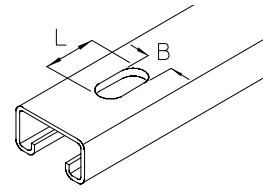



F

