

PENTAFLEX®

Technical information



Table of contents

PENTAFLEX®	4	Design and construction	42
KB	4	Service	50
<i>Agrar</i>	10	Our synergy concept for you	50
FBA	16		
ABS	20		
OBS	22		
FTS	26		
STK	30		
Pipe lead-throughs	34		
OPTI wall strengthener	40		

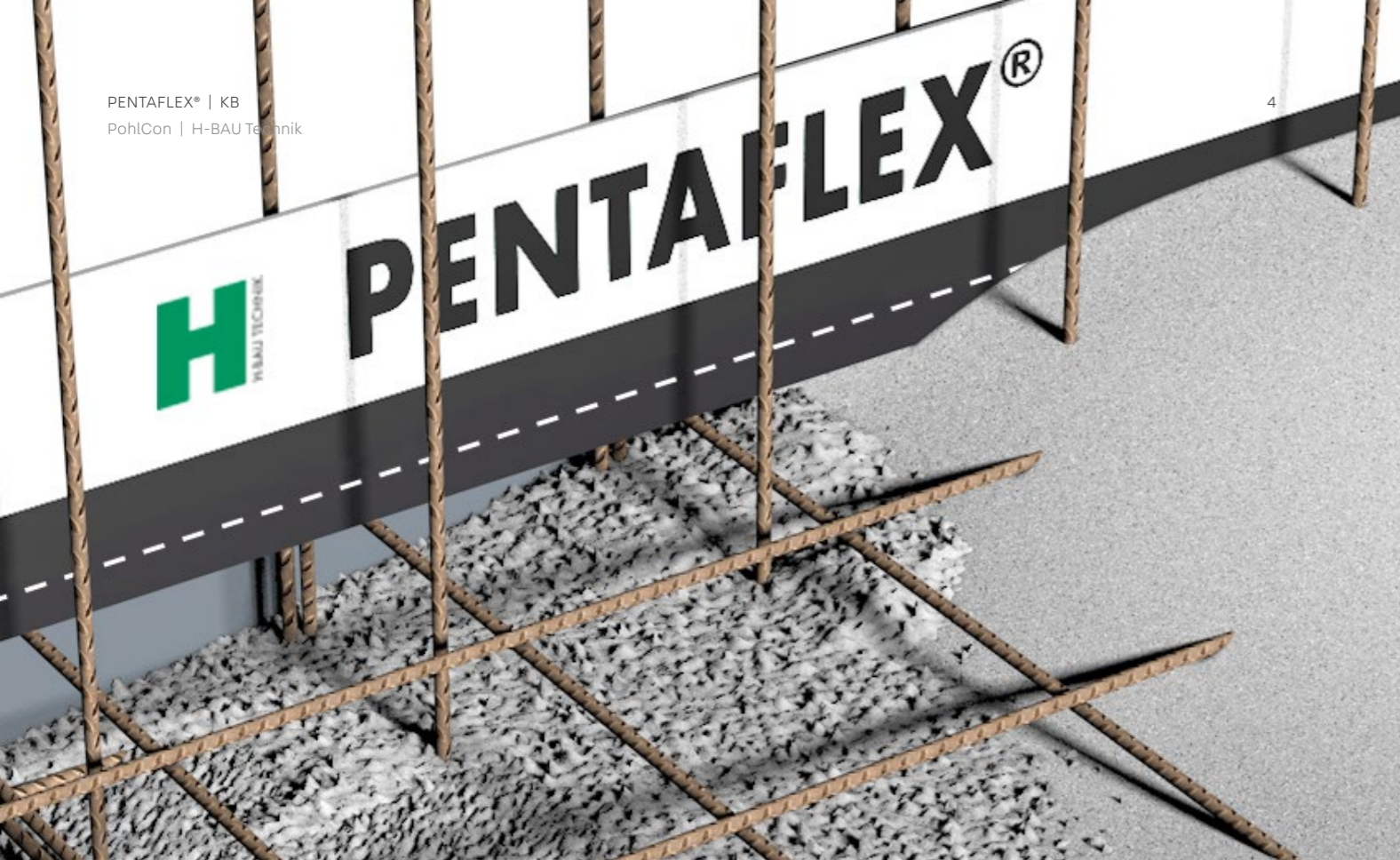

PENTAFLEX® KB

Seam sheet for sealing construction joints

The product

PENTAFLEX® KB elements are fully coated on both sides with a special coating. The bond between the special coating and the fresh concrete reliably prevents water from infiltrating the joint system. An anchoring depth of 30 mm is enough to withstand water pressure of up to 5.0* bar. The high elasticity of the coating maintains a reliable seal if concrete components shrink. The individual elements are 2.00 m long and 167 mm or 80 mm high. They are covered on both sides by a split protective film that is only removed immediately before pouring the concrete.

Area of application

PENTAFLEX® can be used in all horizontal and vertical construction joints subject to water under pressure and water not under pressure:

- Construction joints in wall/base or wall/ceiling areas subject to water under pressure and not under pressure
- Construction joints in wall/wall or floor/floor areas subject to water under pressure and not under pressure

The PENTAFLEX® sealing system is suitable for use in structures of stress class 1 and usage class A in line with the German watertight structure guideline.



Benefits

- Approved for use in Europe with ETA-15/0003
- General building code test certificate P-5120/231/09 MPA-BS
- CE mark
- Tested for watertightness up to 5.0* bar
- Guide marking for continuous monitoring of correct installation
- Simple and reliable connection of the individual elements and points of intersection
- No special tools or adhesive materials required

* Tested to 5.0 bar, 2.0 bar authorised in line with ETA and abP (German building code test certificate) (safety factor of 2.5).

Technical data

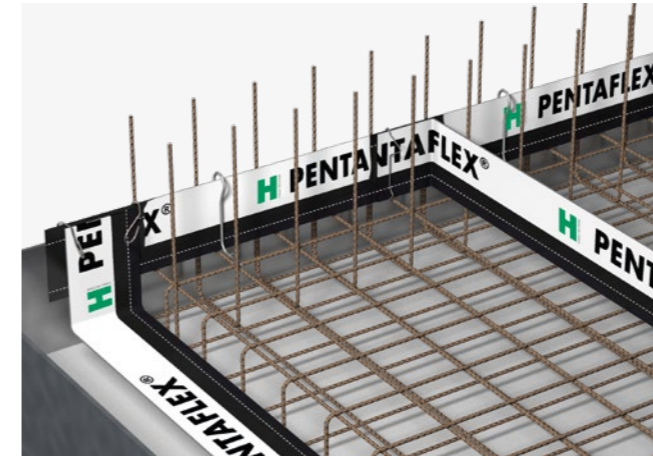

PENTAFLEX® KB 167

- Individual elements made from fully coated, galvanised sheet steel
- Dimensions:
L = 2.0 m
W = 167 mm
Th = 1.2 mm
- Fixed to the reinforcements with one mounting stirrup per metre (see page 12)
- Anchoring depth: ≥ 30 mm
- Tested up to 5.0* bar
- Application: construction joints in wall/base, wall/wall or floor/floor areas



PENTAFLEX® KB 80

- Individual elements made from fully coated, galvanised sheet steel
- Dimensions:
L = 2.0 m
W = 80 mm
Th = 1.2 mm
- Fixed to the wall reinforcement with one mounting stirrup per metre (see page 12)
- Anchoring depth: ≥ 30 mm
- Tested up to 5.0** bar
- Application: construction joints in wall/ceiling area

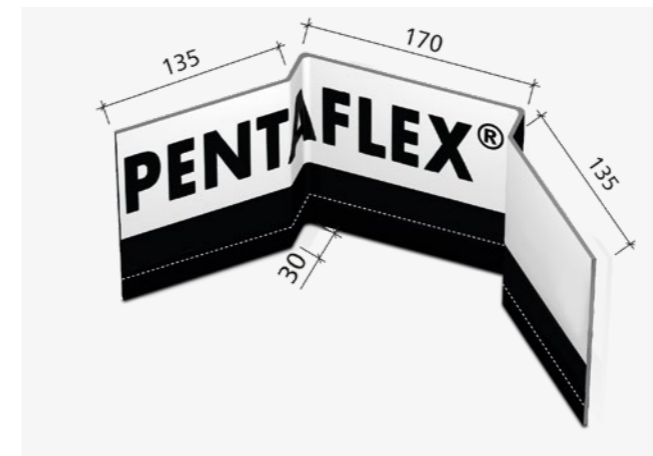

PENTAFLEX® KB ECK

- Individual elements made from fully coated, galvanised sheet steel
- Installed by attaching joint clips to the pre-positioned PENTAFLEX® KB
- Resistant to water under pressure up to 5.0* bar
- Application: Construction joint corners in combination with PENTAFLEX® KB and PENTAFLEX® FTS-Eck

* Tested to 5.0 bar; 2.0 bar permitted in line with abP (German building code test certificate), which corresponds to a safety margin of 2.5x the test pressure

** Tested to 5.0 bar; due to the overall height of < 120 mm, only 1.0 bar of water pressure is permitted in line with abP (German building code test certificate)

Installation instructions

KB167

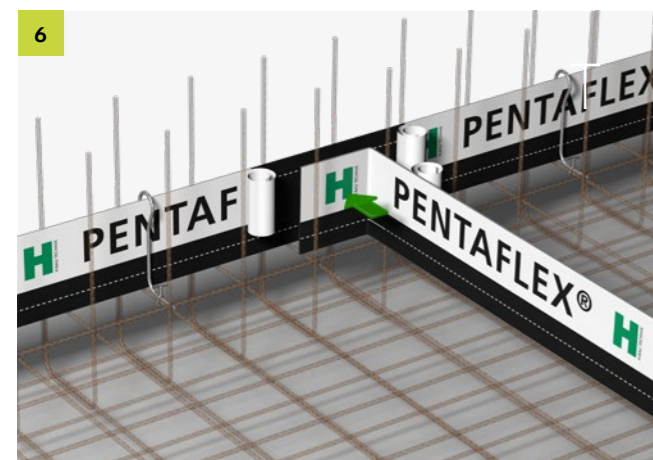
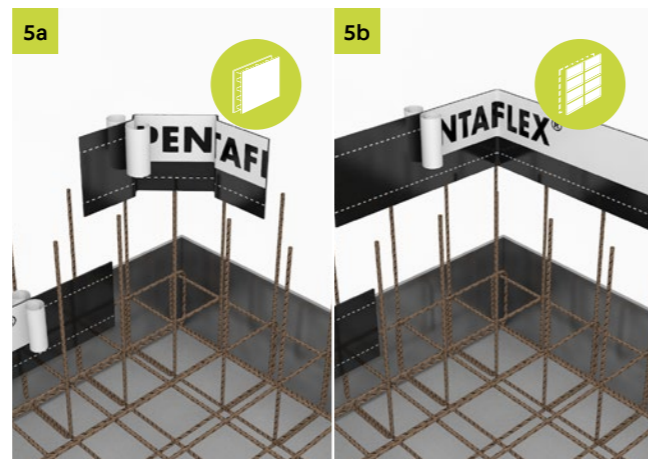
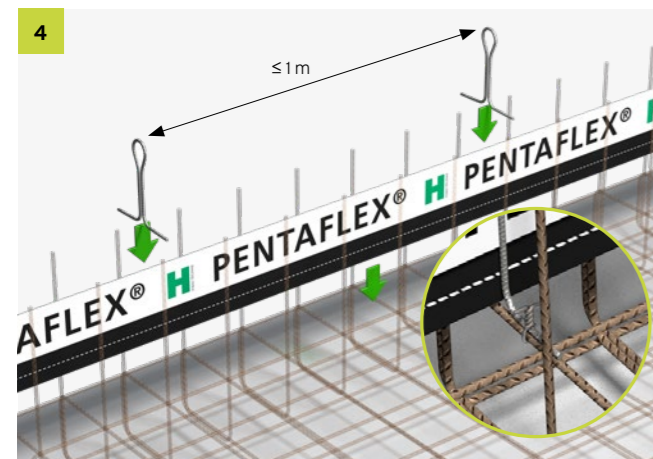
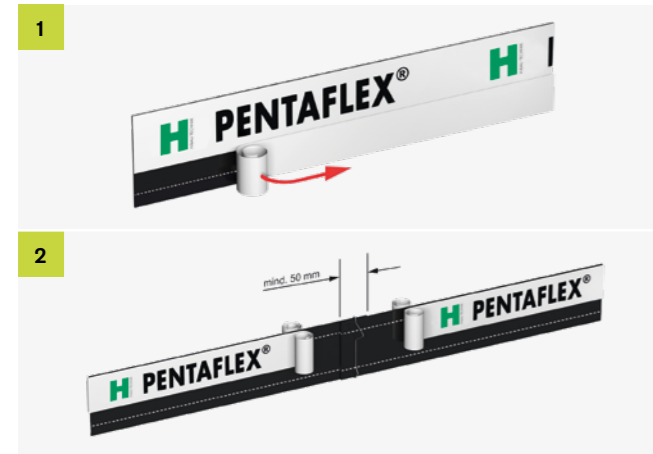

Note on 4:
PENTAFLEX® KB must be attached to the reinforcement with at least one mounting stirrup per metre.
PENTAFLEX® KB must be prevented from shifting or floating upwards while pouring the concrete.

Note on 5a:
It is essential to use PENTAFLEX® KB Eck corner elements when building with element walls.

KB 80

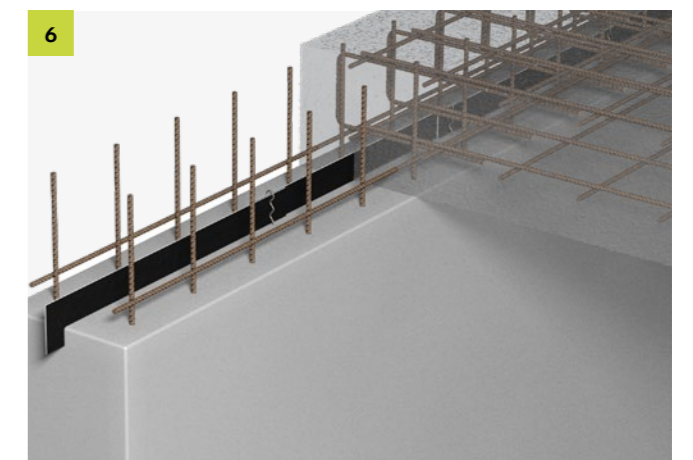
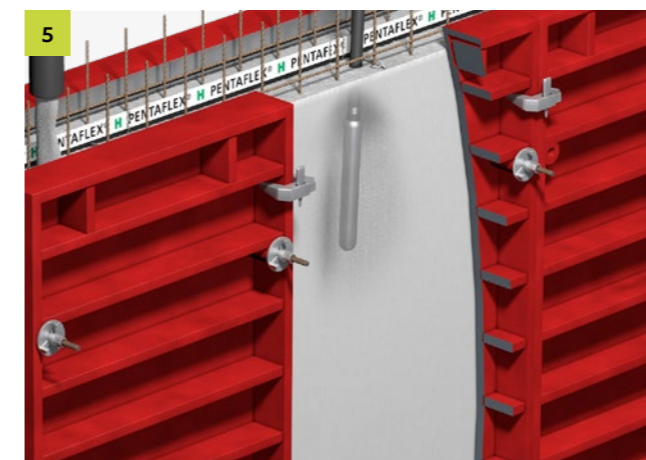
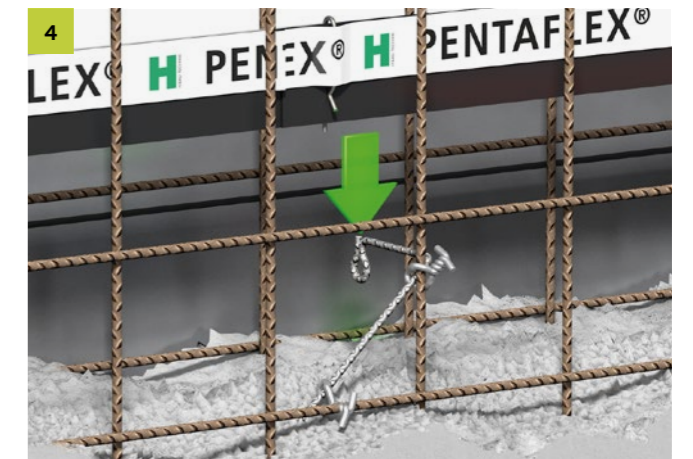
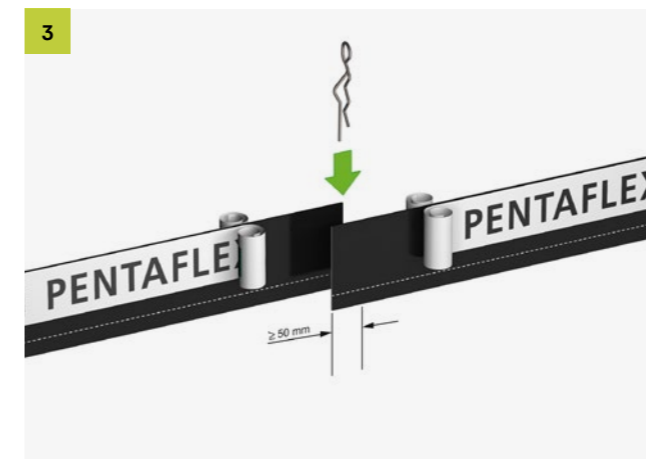
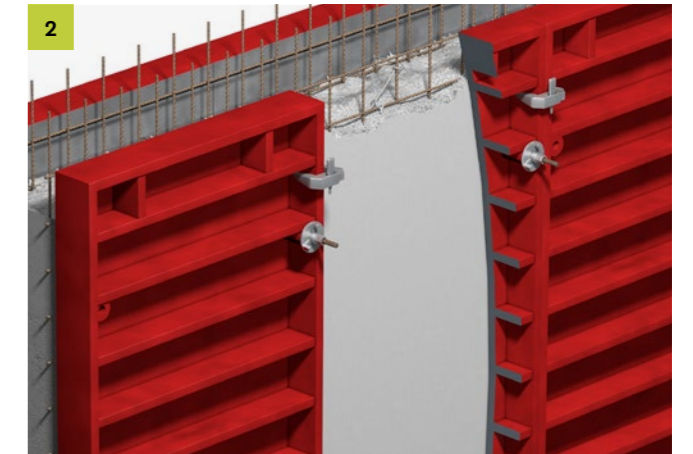
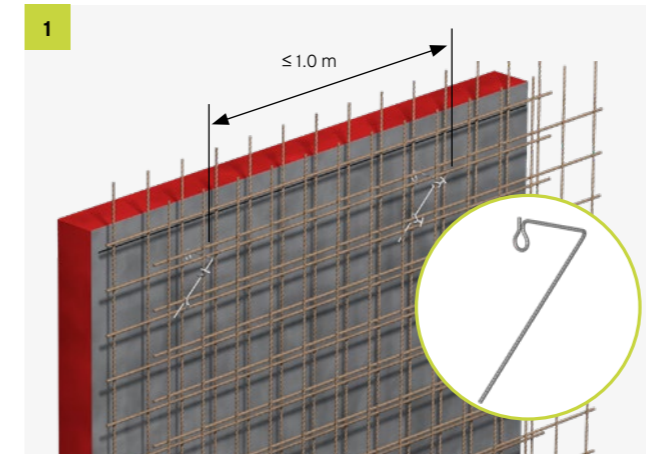

 These installation and use instructions also apply accordingly to all PENTAFLEX® KB 80 applications.

Accessories

PENTAFLEX® mounting stirrup



Omega stirrup

The Omega stirrup can be used in any application. It is used to fix PENTAFLEX® components securely to the top layer of reinforcement.

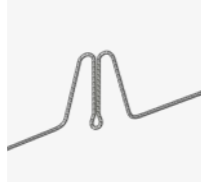

M stirrup

PENTAFLEX® KB can be fixed to the top reinforcement layer even more quickly and easily using the M stirrup.

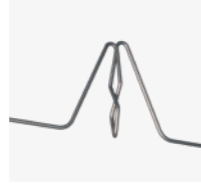

Clamp stirrup

The spring steel clamp stirrups are designed to interlock with PENTAFLEX® elements. This joint system is free-standing on top of the reinforcement and is only fixed in place at specific points.



KB 80 stirrup

The KB 80 stirrup is designed for fixing PENTAFLEX® KB 80 elements in place in the area of wall/ceiling connections. It is tied to the inner mesh reinforcement with twists of wire.

PENTAFLEX® clips



Joint clip 167

Every box of PENTAFLEX® contains an ample supply of joint clips. They are quick and easy to attach for fixing all straight joints of PENTAFLEX® KB elements in place.



Joint clip 80

Every box of PENTAFLEX® contains an ample supply of joint clips. They are quick and easy to attach for fixing all straight joints of PENTAFLEX® KB 80 elements in place.



Cross clip

These clips secure joints in place mechanically. They are used to secure all intersection points.

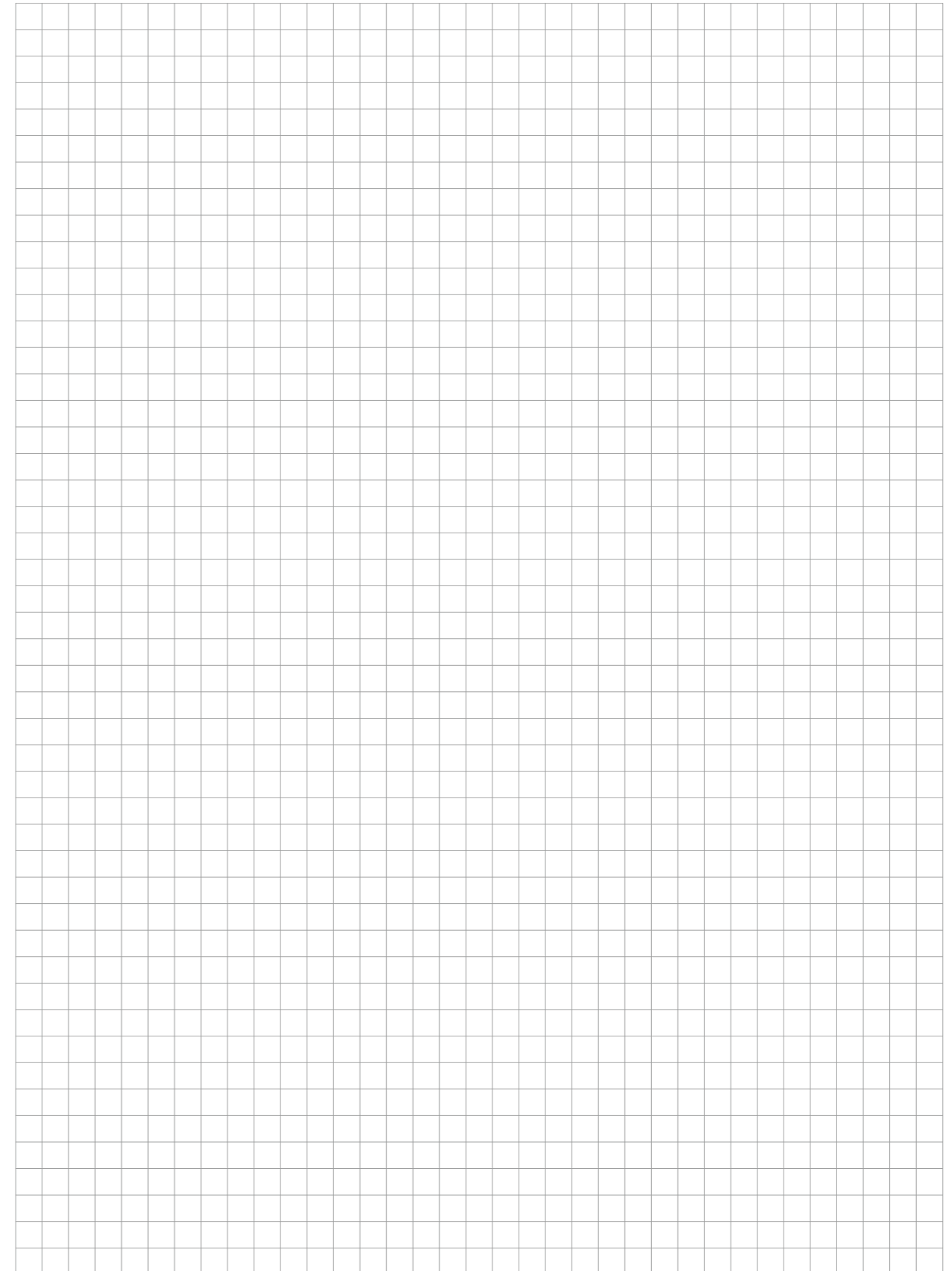

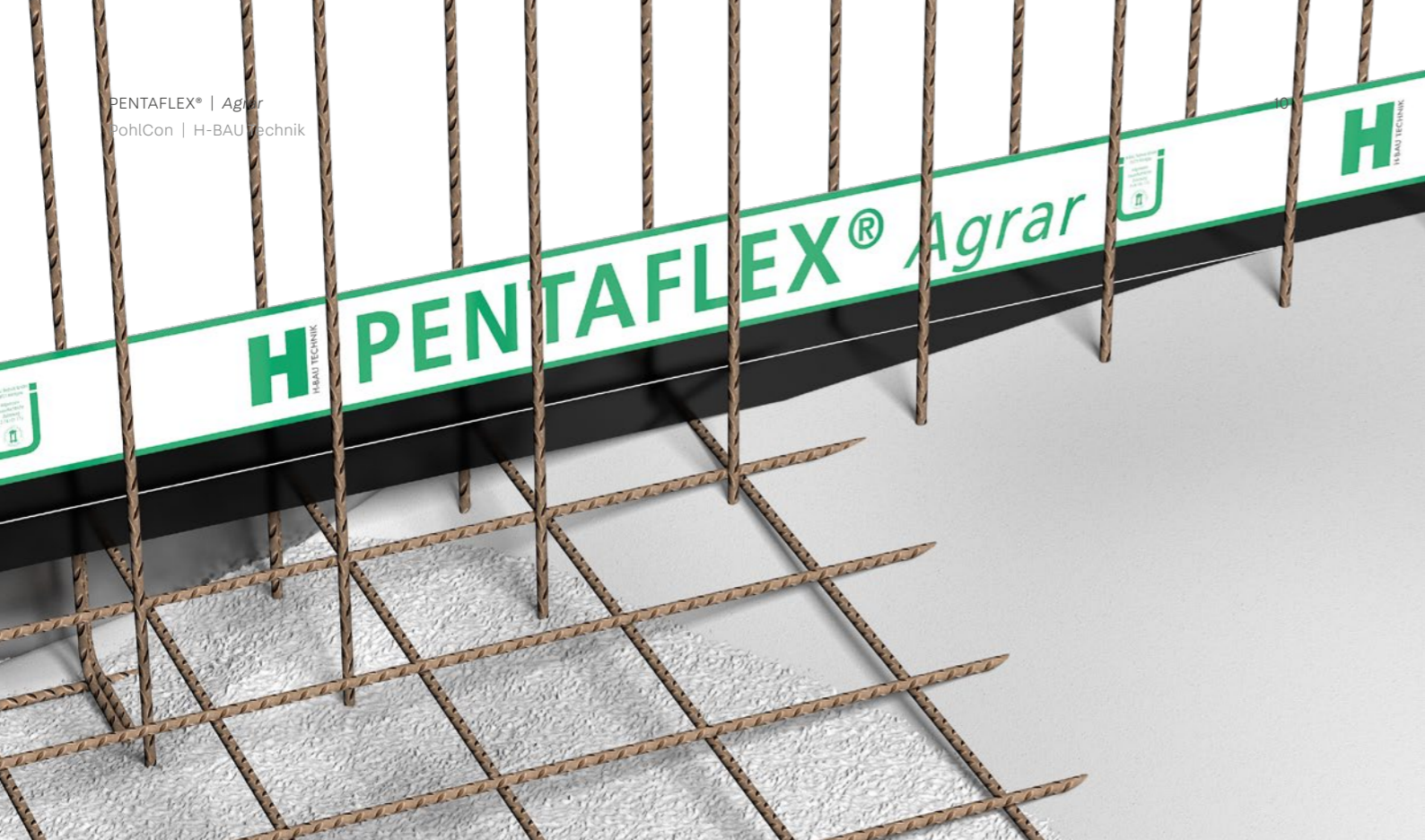

PENTAFLEX® Agrar

Seam sheet for slurry/liquid manure/silage effluent systems

The product

PENTAFLEX® KB167 Agrar elements for agricultural applications are fully coated on both sides with a special coating. The bond between the special coating and the fresh concrete reliably prevents water or other media from infiltrating the joint system. An anchoring depth of 40 mm is enough to withstand a test pressure of up to 2.0* bar. The high elasticity of the coating maintains a reliable seal if concrete components shrink. The seam sheets are covered on both sides by a split protective film that is only removed immediately before pouring the concrete.

Area of application

PENTAFLEX® Agrar can be used in all horizontal and vertical construction joints and in the presence of water under pressure, slurry, liquid manure and silage effluent (JGS systems).

PENTAFLEX® Agrar is suitable for e.g.:

- Containers
- Collection pits
- Slurry pits
- Silos
- Moveable silos
- Covered slurry lagoons and channels
- Solid manure platforms
- Filling areas



Benefits

- DIBt approval Z-74.101-175 for use in biogas and JGS storage and filling facilities
- Tested up to 2.0* bar
- Guide marking for continuous monitoring of correct installation
- Simple and secure connection
- No special tools or adhesive materials required

* Tested to 2.0 bar; DIBt approval to 0.8 bar (safety factor of 2.5).

Technical data

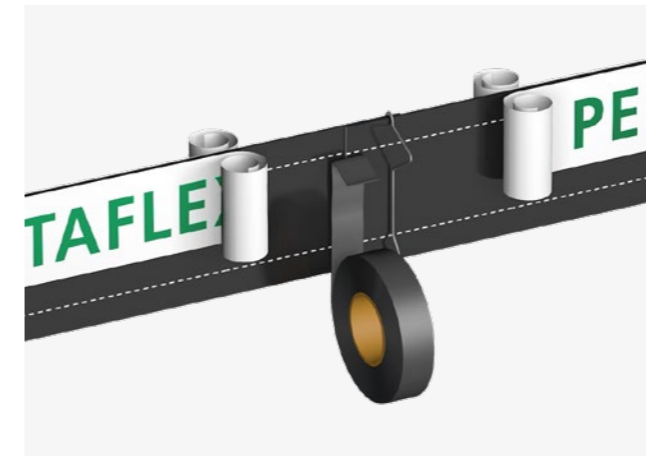

PENTAFLEX® Agrar

- Galvanised sheet steel
- Fully coated
- For sealing construction joints
- Dimensions:
L = 10.0 m
W = 167 mm
Th = 1.2 mm

PENTAFLEX® tape

- In strip format
- For covering overlapping joints with cut edges
- Dimensions:
L = 200 mm
W = 38 mm
Th = 1.0 mm

Planning notes

- For use in biogas and JGS storage and filling facilities
- Storage substrate according to permit Z-74.101-175 section 1
- Container filling height: 8.0 m
- Construction joints ≤ 0.2 mm crack width
- Overlapping joints using PENTAFLEX® Agrar trimmed on site must be documented
- Installed system must be inspected and approved by an expert

Construction notes

- Construction company in line with the German Ordinance on Facilities for Handling Substances Hazardous to Water (AwSV) (§62) with suitable certification
- Documented product briefing performed by the manufacturer
- Processing temperature: -5°C / +45°C
- Fixed to the reinforcement with one Omega stirrup per metre
- Anchoring depth ≥ 40 mm
- Overlap length at joint ≥ 80 mm
- For overlapping joints of trimmed PENTAFLEX® Agrar, the cut edges must be positioned on the side facing away from the contained material and covered using PENTAFLEX® tape. Their position must be documented in the plan.
- The documented installation inspection (appendix 7 permit Z-74.101-175) must be approved by the responsible expert before pouring the concrete.

Accessories



Omega stirrup

For fixing to the top reinforcement layer



Joint clip 167

For securing overlapping joints mechanically



Cross clip

For securing cross joints mechanically

Installation instructions

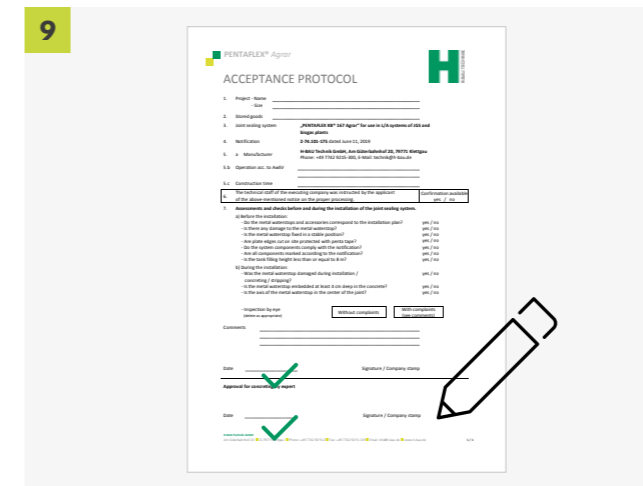
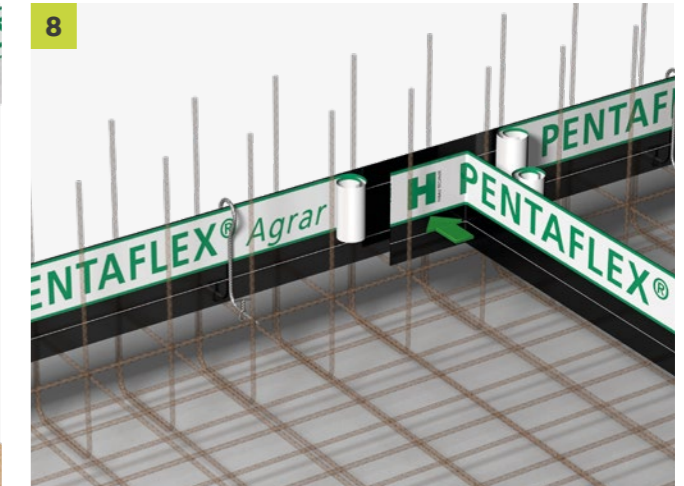
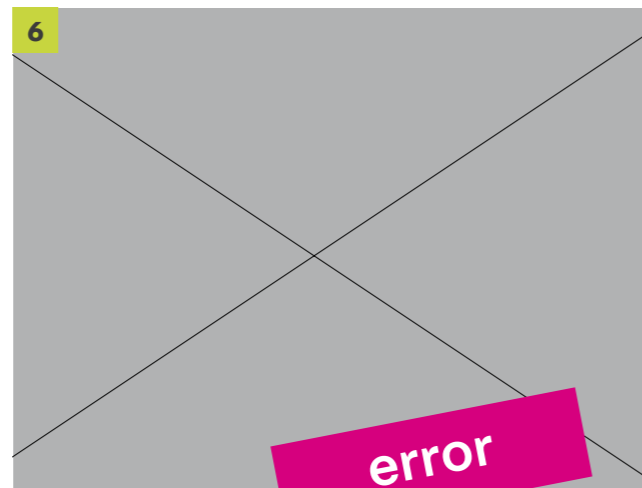
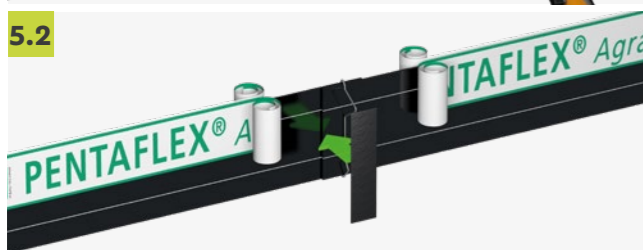
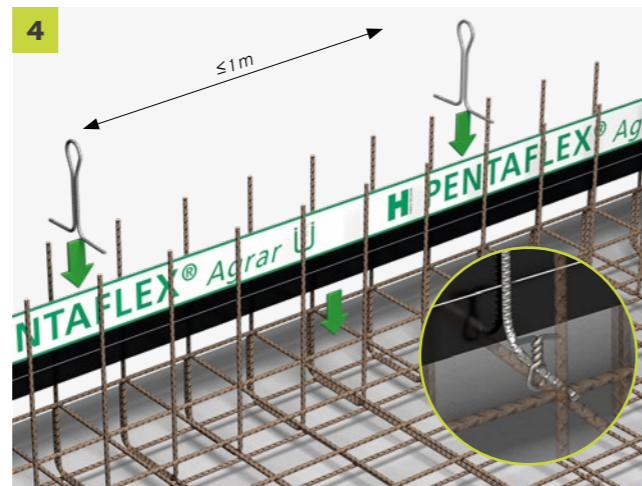
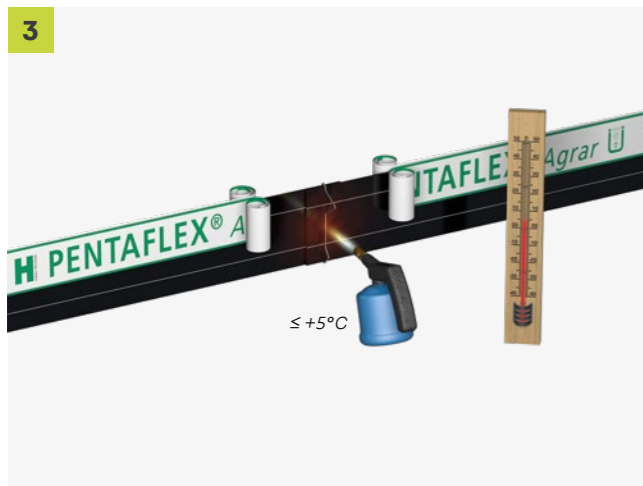
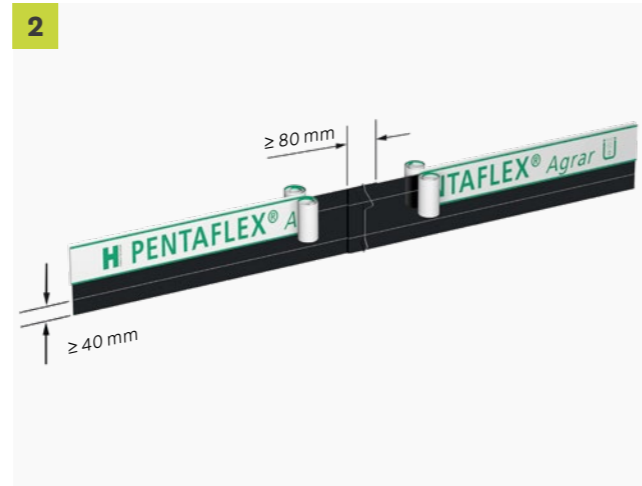

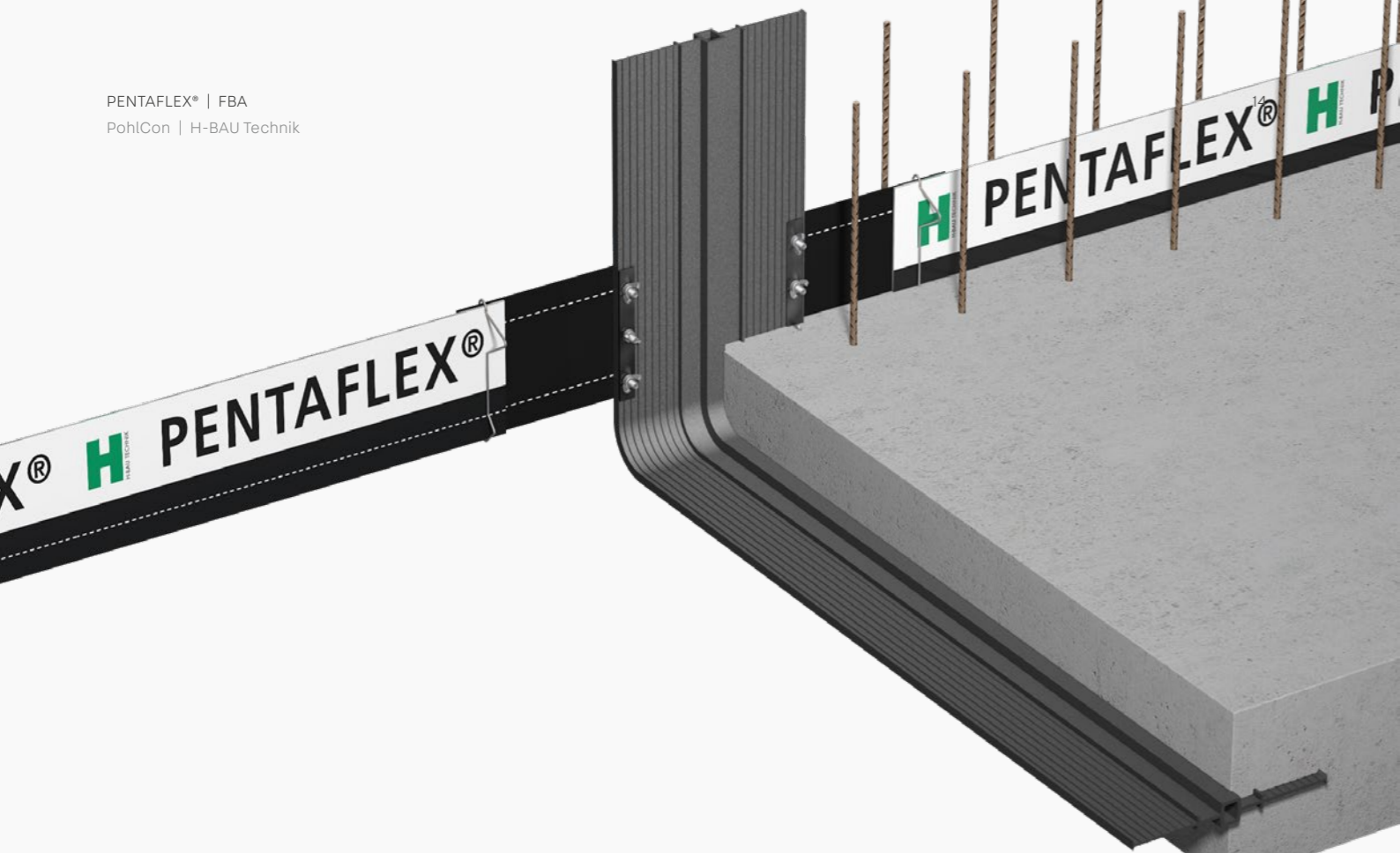

Technical data

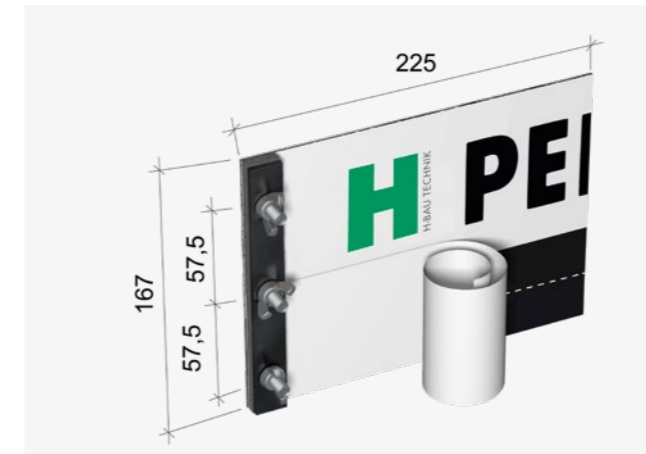

Basic information

- Individual elements made from fully coated, galvanised sheet steel
- Dimensions:
L = 225 mm
W = 167 mm
Th = 1.2 mm
- Anchoring depth: ≥ 30 mm
- FBA including swelling strip, clamping strip and screws
- Delivered as a set (2 pieces)
- Accessories:
A-CV and AS-CV shuttering strips

PENTAFLEX® FBA

Sealed transition to joint tapes

The product

The PENTAFLEX® FBA joint tape connection consists of a clamping device with a sealing strip. FBA can be used to connect KUNEX® joint tapes with PENTAFLEX® KB elements. The FBA is connected to the joint tape at the end piece of the PENTAFLEX® element using a screw-type clamping device.

Area of application

PENTAFLEX® FBA joint tape connections can be used to integrate KUNEX® construction joint and expansion joint tapes into the sealing concept in a system-compatible manner. Transitions from PENTAFLEX® seam sheets to KUNEX® joint tapes can be installed quickly and easily.



Benefits

- Secure connection of PENTAFLEX® to KUNEX® joint tapes
- Connection tested up to 5.0 bar
- Easy assembly
- No special tools or adhesive materials required

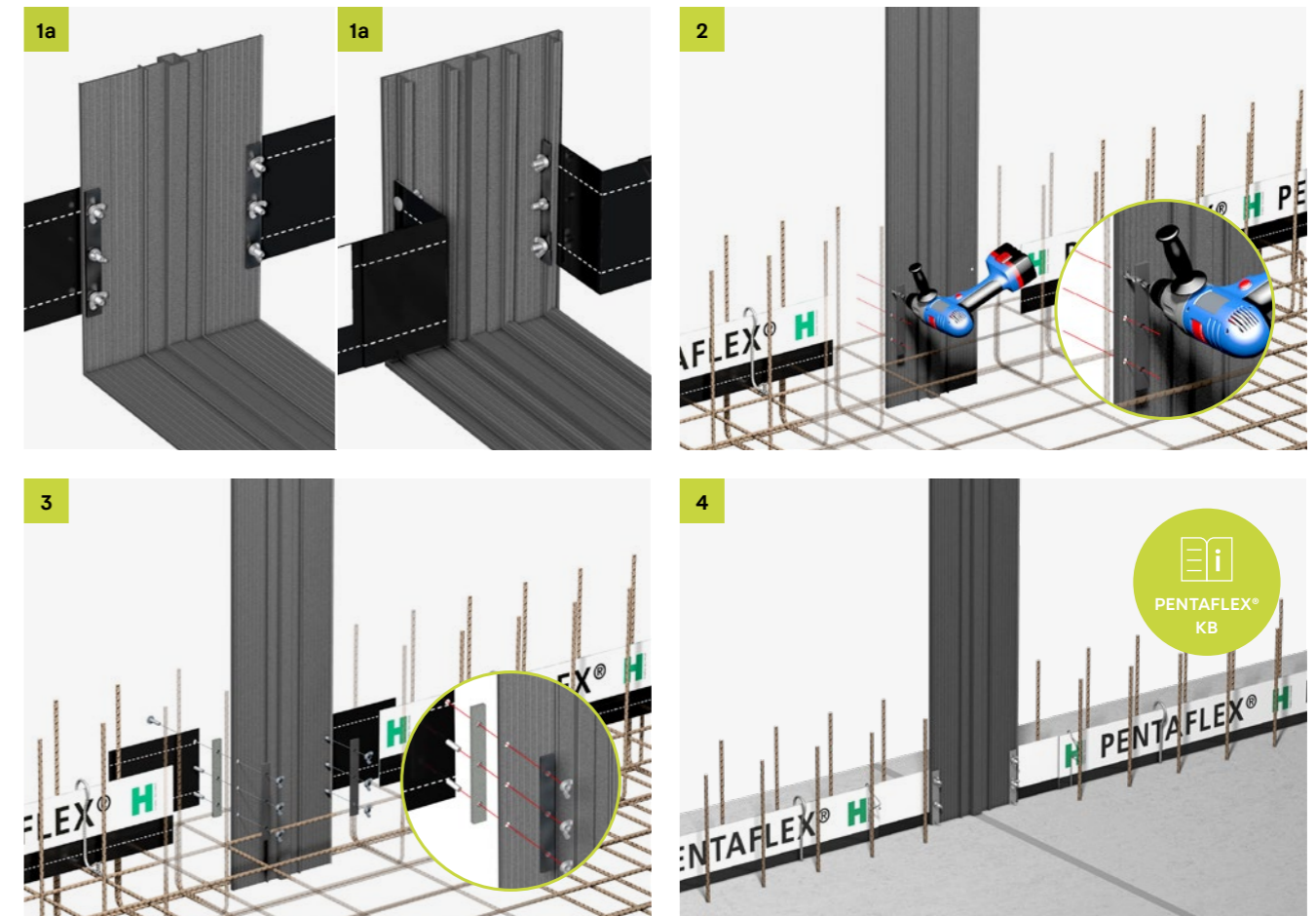

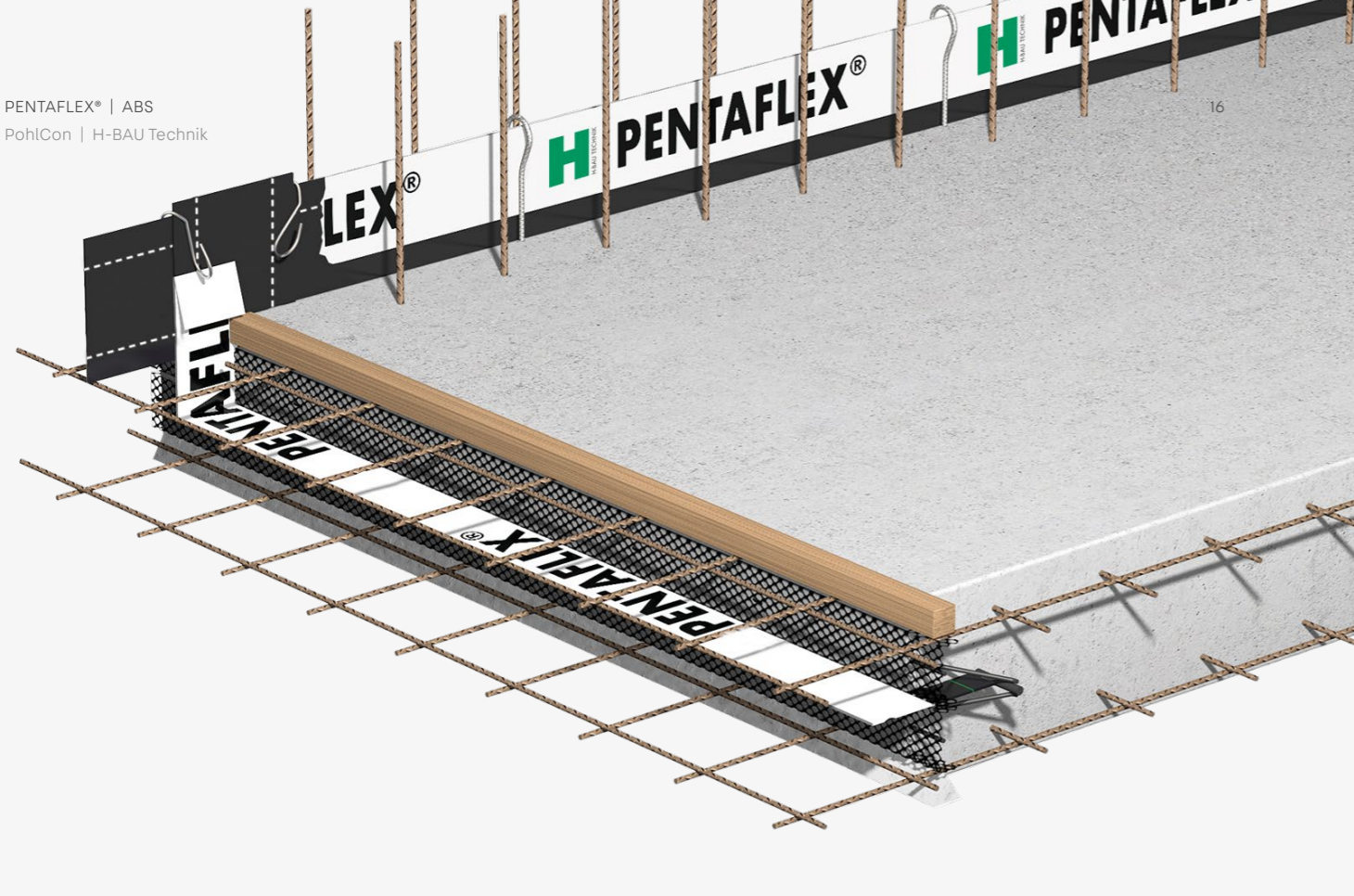

PENTAFLEX® ABS

Shuttering element with seam sheet for rough or interlocking construction joints

The product

The PENTAFLEX® ABS shuttering element is a combination of seam sheet and profiled shuttering. The joints are securely sealed using tried-and-tested PENTAFLEX® KB elements. The shuttering is created using dimensionally stable expanded metal elements reinforced using a special stirrup construction. The ABS element can be supplied for rough or interlocking joints (ABS-R, ABS-V).

Area of application

PENTAFLEX® ABS is used to create construction joints for reinforced concrete slabs that are exposed to water (floors, walls and ceilings), particularly for applications that require bonded joints with high shear strengths.



Benefits

- Approved for use in Europe with ETA-15/0003
- General building code test certificate P-5120/231/09 MPA-BS
- CE mark
- High shear strength in the bond joint
- Watertight up to 5.0* bar
- Joints do not have to be welded
- For continuous reinforcement
- PENTAFLEX® special coating resistant to organic effluents
- Easy and secure connection with PENTAFLEX® KB in floor/wall joints

* Tested to 5.0 bar, 2.0 bar authorised in line with ETA and abP (German building code test certificate) (safety factor of 2.5).

Technical data

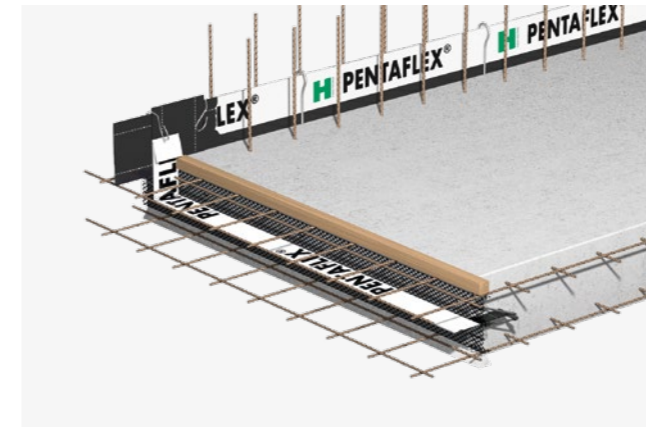

Basic information

- Shuttering element made from E10/grade DC04 expanded metal with bracing lattice beam structure in B500B steel
- PENTAFLEX® KB seam sheet in line with abP (German building code test certificate)
- Area of application: Floor/floor, ceiling/ceiling, wall/wall
- Shuttering element standard length: L=2.40 m
- Fixed length and special forms with e.g. off-centre joints possible
- Shuttering elements for element walls available on request

System cross section

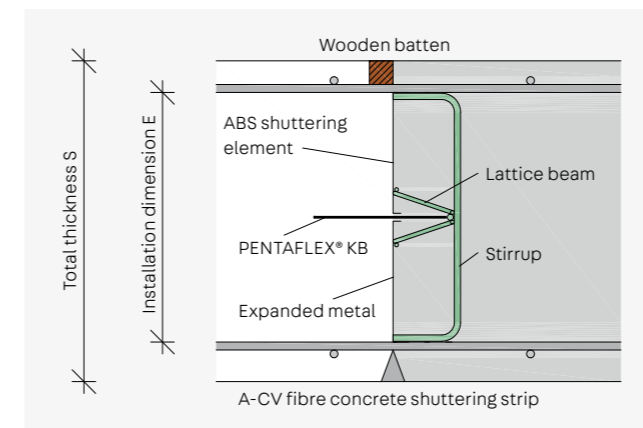

The A-CV shuttering strip reliably reduces the leakage of concrete and the associated loss of fine particles to a minimum. It can accommodate bar diameters from 6 to 14 mm and is available for concrete coverages from 20 to 60 mm thick.

Versions

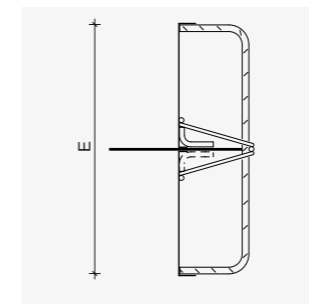

ABS R for rough joints in line with EC2

- For floor/floor, ceiling/ceiling
- For wall/wall with shorter lattice beam
- Installation dimension: 80 - 590 mm

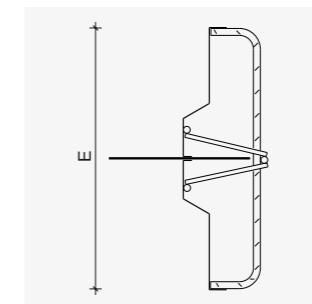

ABS V for interlocking joints in line with EC2

- For floor/floor, ceiling/ceiling
- For wall/wall with shorter lattice beam
- Installation dimension: 140 - 590 mm

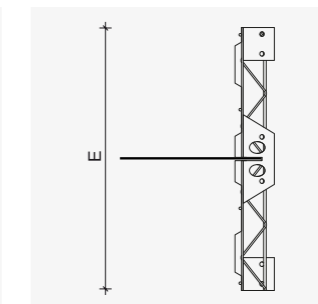

ABS V-S for interlocking joints in line with EC2

- Reinforced version
- For floor/floor, ceiling/ceiling, wall/wall
- Installation dimension: 600 - 1990 mm



To compile a quotation, we require information on the intended use, joint length, installation heights and connection points.

Installation instructions

Floor/floor, ceiling/ceiling

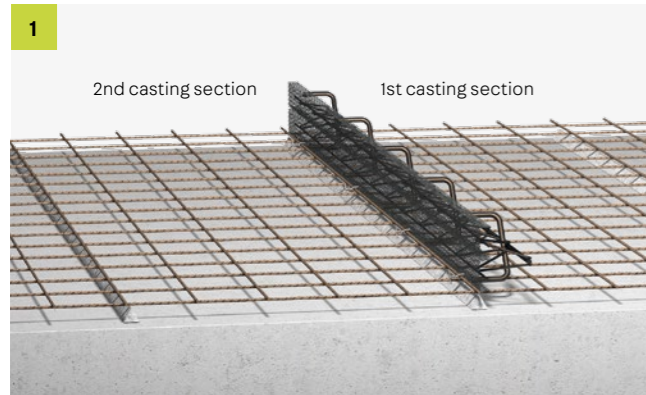

Insert a suitable spacer, size c_{nom} , on the subbase/shuttering at the point where the construction joint will be located (at the level of the expanded metal sheets). Install the ABS elements on the lower reinforcement layer. Select the direction of installation so that the lattice beam protrudes into the first concreted section. Attach it to the lower reinforcement using binding wire. Alternatively, the element can be welded to the reinforcement.

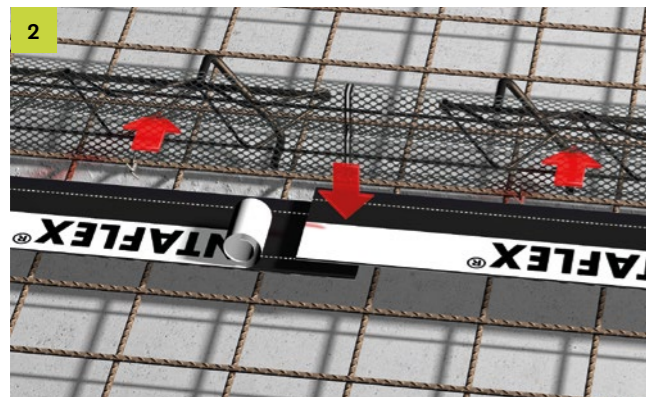

Extend the ABS elements with butt joints. Peel the film off one side of the PENTAFLEX® KB element (top and bottom pieces) and push it into the shuttering as far as it will go. The seam sheets must overlap by 50 mm, be pressed firmly together and be secured with a cross clip. At temperatures below +5°C, the joint surface must first be heated.

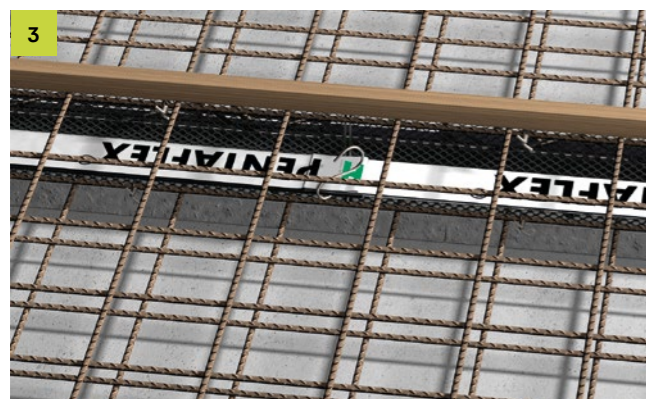

Lay the upper reinforcement and the shuttering for the upper concrete layer. Attach the ABS element to the upper reinforcement using binding wire. Alternatively, the element can be welded to the reinforcement.

Before casting the second section, remove the protective film from the top and bottom of the seam sheet.

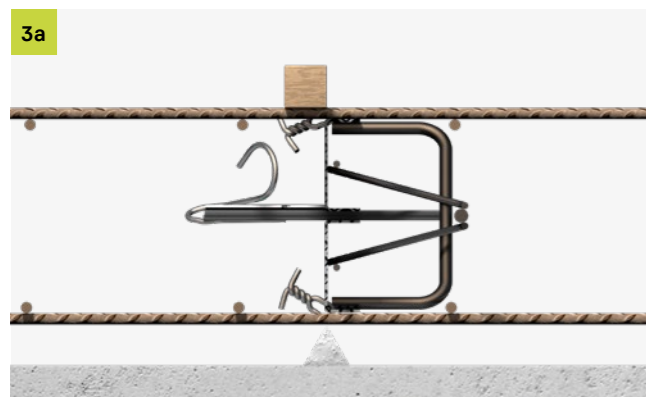

Cross-section of the installation situation

Wall/wall

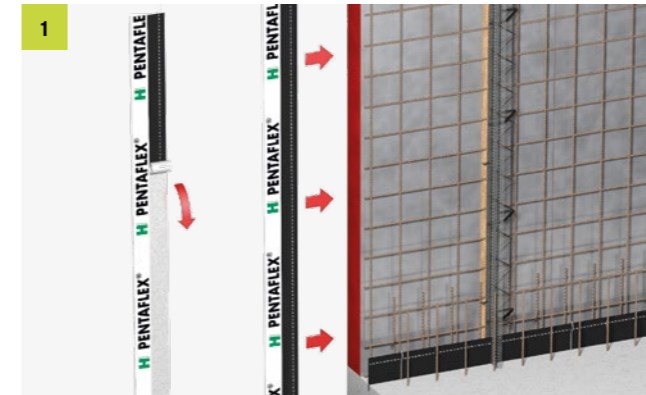

Position the exterior shuttering and attach a trapezoidal strip at the position of the construction joint. Position the outer reinforcement. Use spacers that are designed for use with watertight concrete. Position the ABS element over the PENTAFLEX® KB element of the floor/wall joint and tie or weld it to the reinforcement. Peel off the protective paper on both sides in the area of the first casting section and insert the sheet into the shuttering as far as it will go.

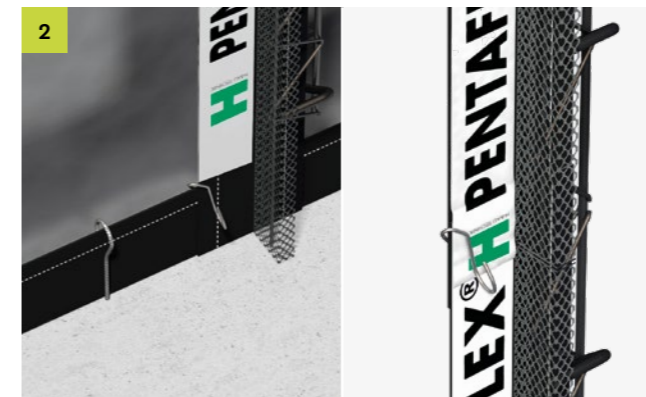

Butt joints must overlap by 50 mm. At temperatures below +5°C, the joint area must first be heated. Secure the connection using a cross clip.

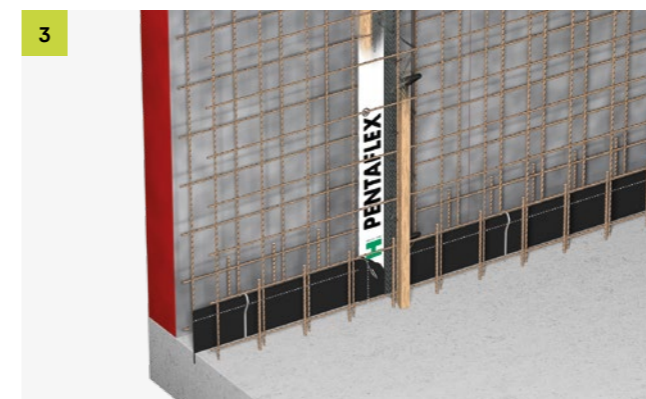

Install the inner reinforcement and secure it to the ABS element (using binding wire or welding). Fasten the trapezoidal strip and close the shuttering. Use tie points that are compatible with watertight construction.

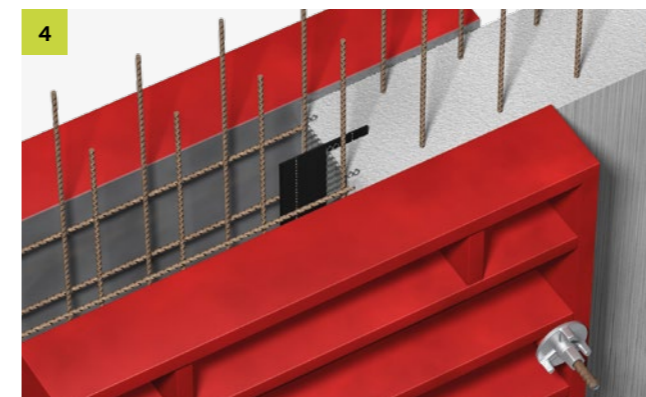

Before erecting the shuttering for the second casting section, remove the remaining protective film from the PENTAFLEX® KB element, install the component's rebar and close the shuttering.

Accessories

A-CV fibre concrete shuttering strip

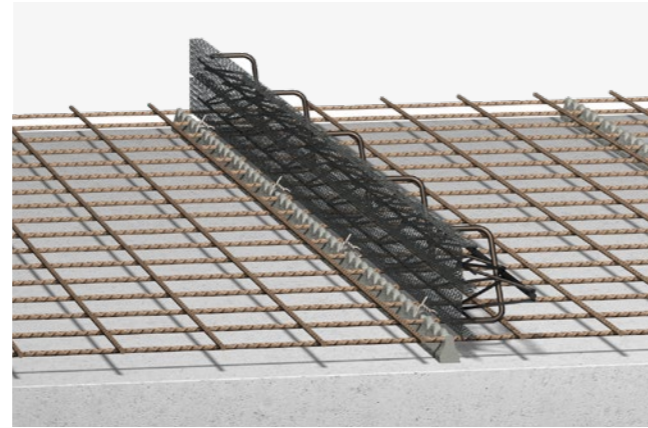
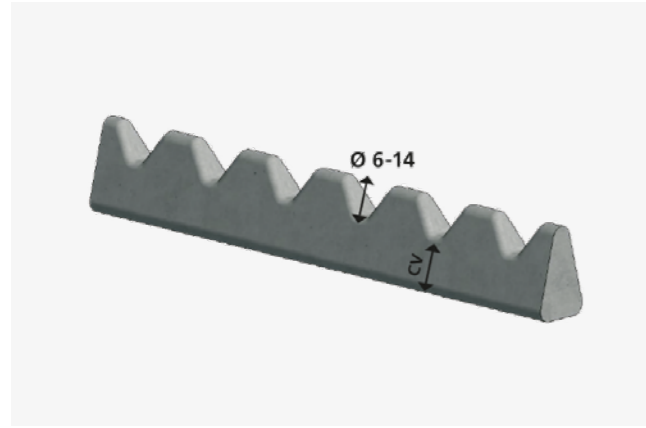

The product

This spacer is made from fibre-reinforced concrete with a 50 mm reinforcement grid. It is an ideal complement to the PENTAFLEX® ABS shuttering element with either a rough or interlocking design. The A-CV shuttering strip reliably reduces the leakage of concrete and the associated loss of fine particles to a minimum.

It can accommodate bar diameters from 6 to 14 mm and is available for concrete coverages from 20 to 60 mm thick. This makes it the perfect installation aid for steel-bar reinforcements.

Area of application

The A-CV shuttering strip also serves as a gauge when installing steel bars, eliminating the need to measure and mark a grid on the subbase. The A-CV shuttering strip is used for a range of concrete covering thicknesses when laying longitudinal and transverse reinforcements.



Benefits

- No seepage from construction joints
- Saves time
- Improves quality
- Universal use
- Simplifies on-site monitoring and rebar inspection

Type	Concrete cover mm	Height/length mm
A-CV 20	20	40/1000
A-CV 25	25	45/1000
A-CV 30	30	50/1000
A-CV 35	35	55/1000
A-CV 40	40	60/1000
A-CV 45	45	65/1000
A-CV 50	50	70/1000
A-CV 60	60	80/1000

AS-CV fibre concrete shuttering strip

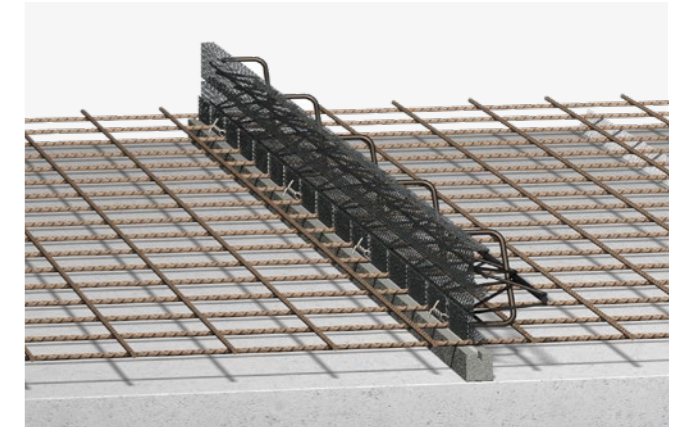
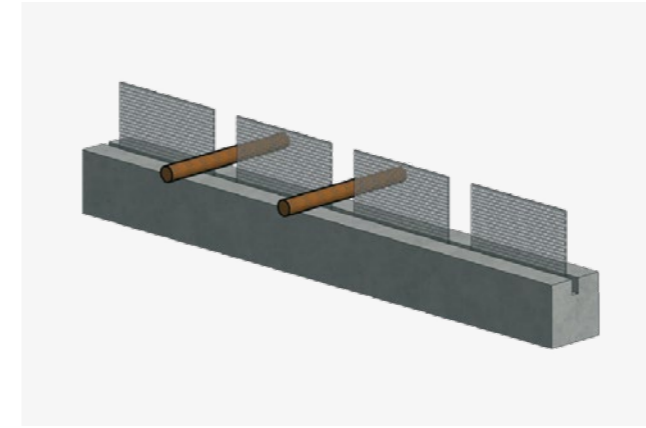

The product

Spacers ensure that the reinforcements are covered with concrete and shuttering elements provide a simple and economical way of making construction joints watertight. But the areas between the reinforcement bars crossing the joint are a major flaw. These sections of the construction joint shuttering are not normally closed. This allows concrete to leak out, something which is not conducive to achieving a geometrically perfect joint. A huge number of fine particles are washed out. This not only impacts the watertightness of the concrete in the barrier layer, but also affects the quality of the next casting section



Benefits

- Perfectly geometric formation of construction joints
- Ensures that the watertight concrete is homogeneous
- Unhindered cross-sectional formation in the second casting section over the entire slab thickness
- Perfect rebar spacing without measurement

AS-CV	Concrete cover mm	Height/length mm
30/100	30	100
30/150	30	150
30/200	30	200
35/100	35	100
35/150	35	150
35/200	35	200
40/100	40	100
40/150	40	150
40/200	40	200
50/100	50	100
50/150	50	150
50/200	50	200

Please state the diameter of the rebar being used.

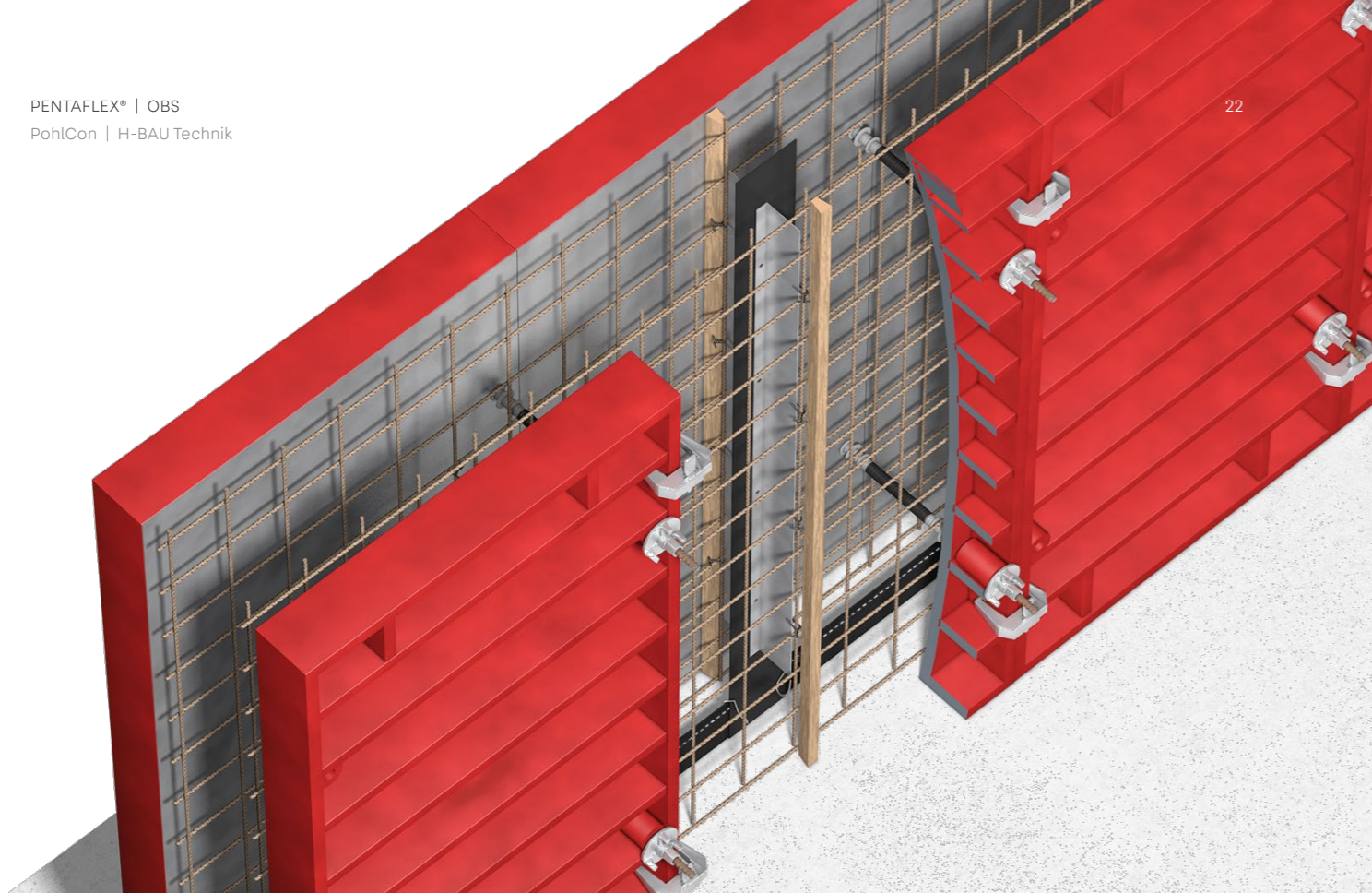

PENTAFLEX® OBS

Element for sealing and creating crack control joints in walls / floor slabs

The product

PENTAFLEX® OBS crack control elements for in-situ concrete components consist of a joint element with the tried-and-tested PENTAFLEX® special coating and galvanised sheet steel wings that weaken the concrete cross-section.

The wall elements are manufactured as standard in 2.50 m, 2.75 m and 3.00 m lengths. The floor slab elements are available in 2.50 m lengths as standard. The slotted wings are available for various component thicknesses. The wall elements are supplied ready for installation. The floor element is a combination of crack control element and seam sheet.

Area of application

PENTAFLEX® OBS crack control elements are used to create cracks at predetermined points in in-situ concrete components. The sealing element seals the resulting crack against both water under pressure and not under pressure. This stops shrinkage cracks from occurring randomly – instead they form at the planned points, which are also immediately sealed.



Benefits

- Approved for use in Europe with ETA-15/0003
- General building code test certificate P-5120/231/09 MPA-BS
- CE mark
- Elements are quick and easy to assemble
- Reliably creates and seals control cracks
- Watertight up to 5.0* bar
- Easy, secure connection with PENTAFLEX® KB

Technical data



OBS wall

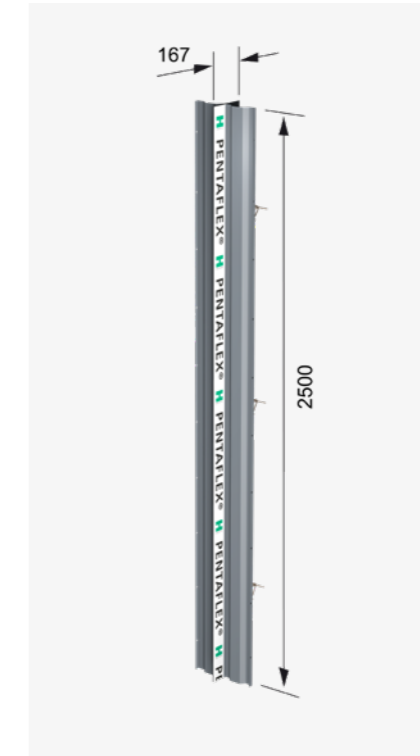

OBS floor

Wall application

- PENTAFLEX® KB seam sheet
- Element length: L = 2.50; 2.75; 3.00 m, Fixed lengths available on request
- Standard installation dimension: E = 140 and 180 mm for wall thickness 240-250 and 300 mm
- Other E dimensions available on request
- Seam sheet overlap at top and bottom for connection to PENTAFLEX® KB

Floor slab application

- PENTAFLEX® KB seam sheet
- Element length: L = 2.50
- Installation dimension: E ≥ 80 mm (OBS G-S)
- Installation dimension: E ≥ 140 mm (OBS V-S)
- Interlocking joint in line with EC 2

System cross section

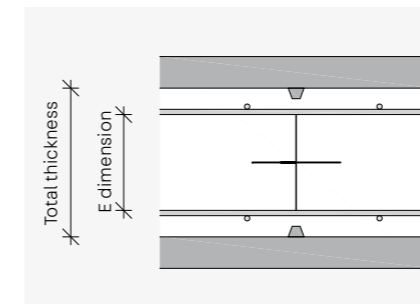

OBS wall

E dimension: 140 and 180 mm for wall thickness 240-250 and 300 mm

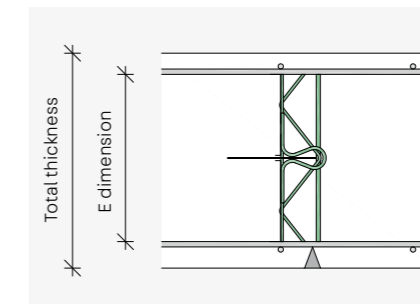

OBS G-S floor

E dimension: 80 to 1000 mm

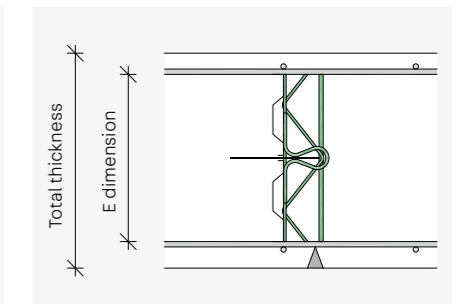

OBS V-S floor

E dimension: 140 to 1000 mm



OBS wall

The correct concrete cover layer must be adhered to in the area of the trapezoidal strip.



Larger installation dimensions available on request. Our Application Technology department will be happy to assist you.

* Tested to 5.0 bar, 2.0 bar authorised in line with ETA and abP (German building code test certificate) (safety factor of 2.5).

Installation instructions

Wall

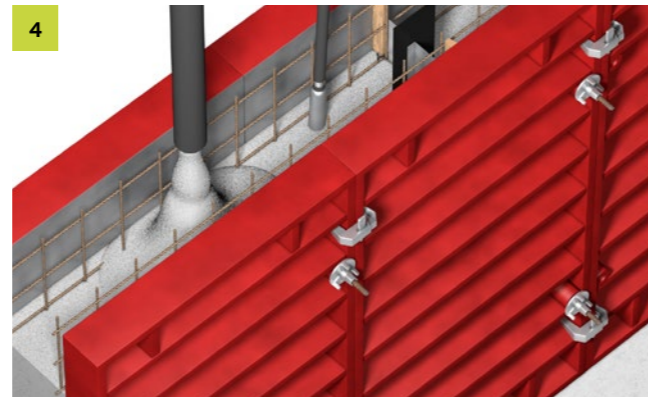
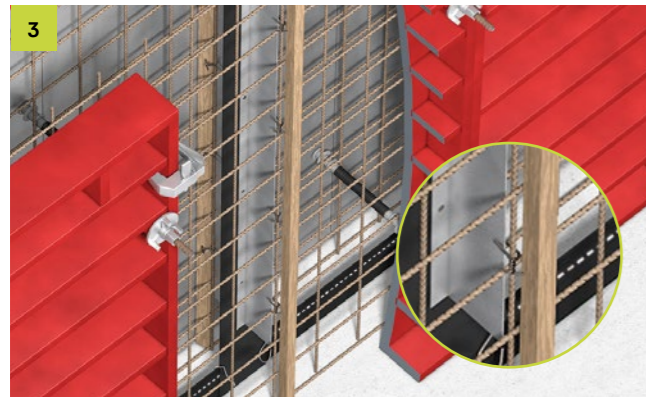

Floor

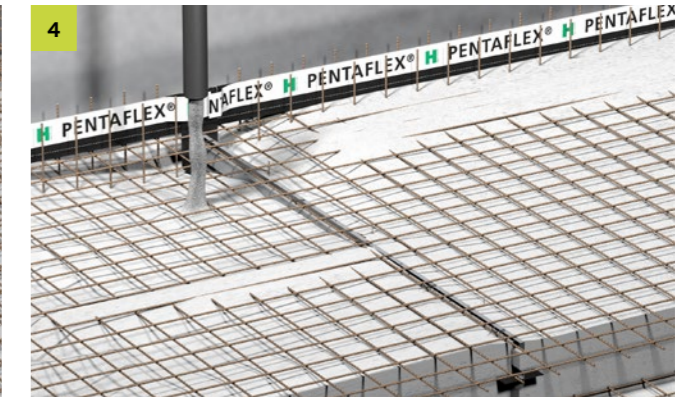
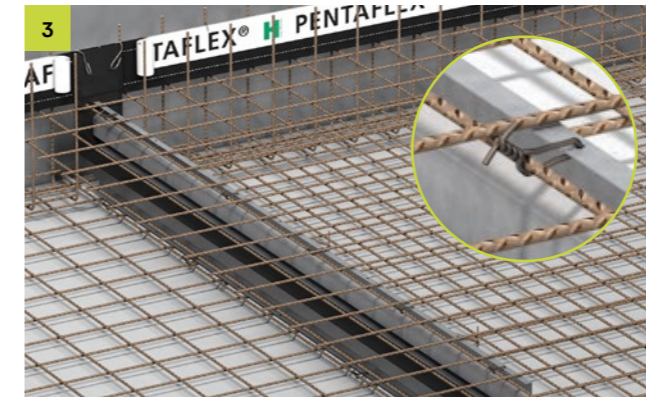
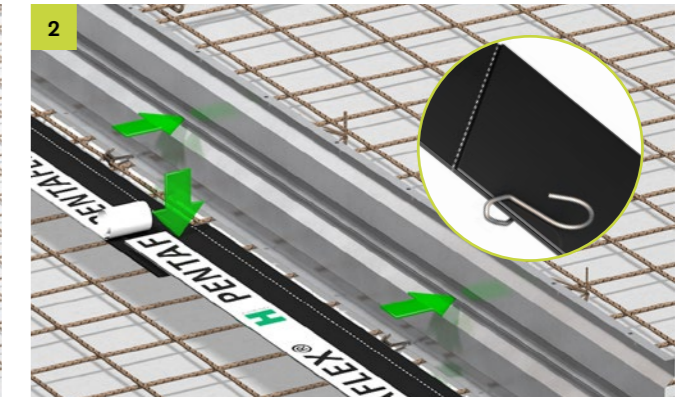
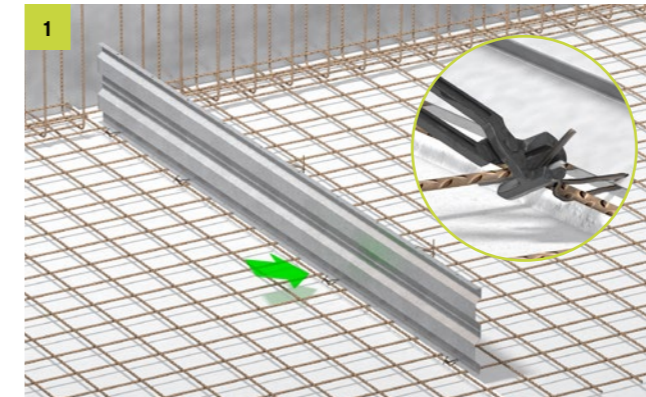

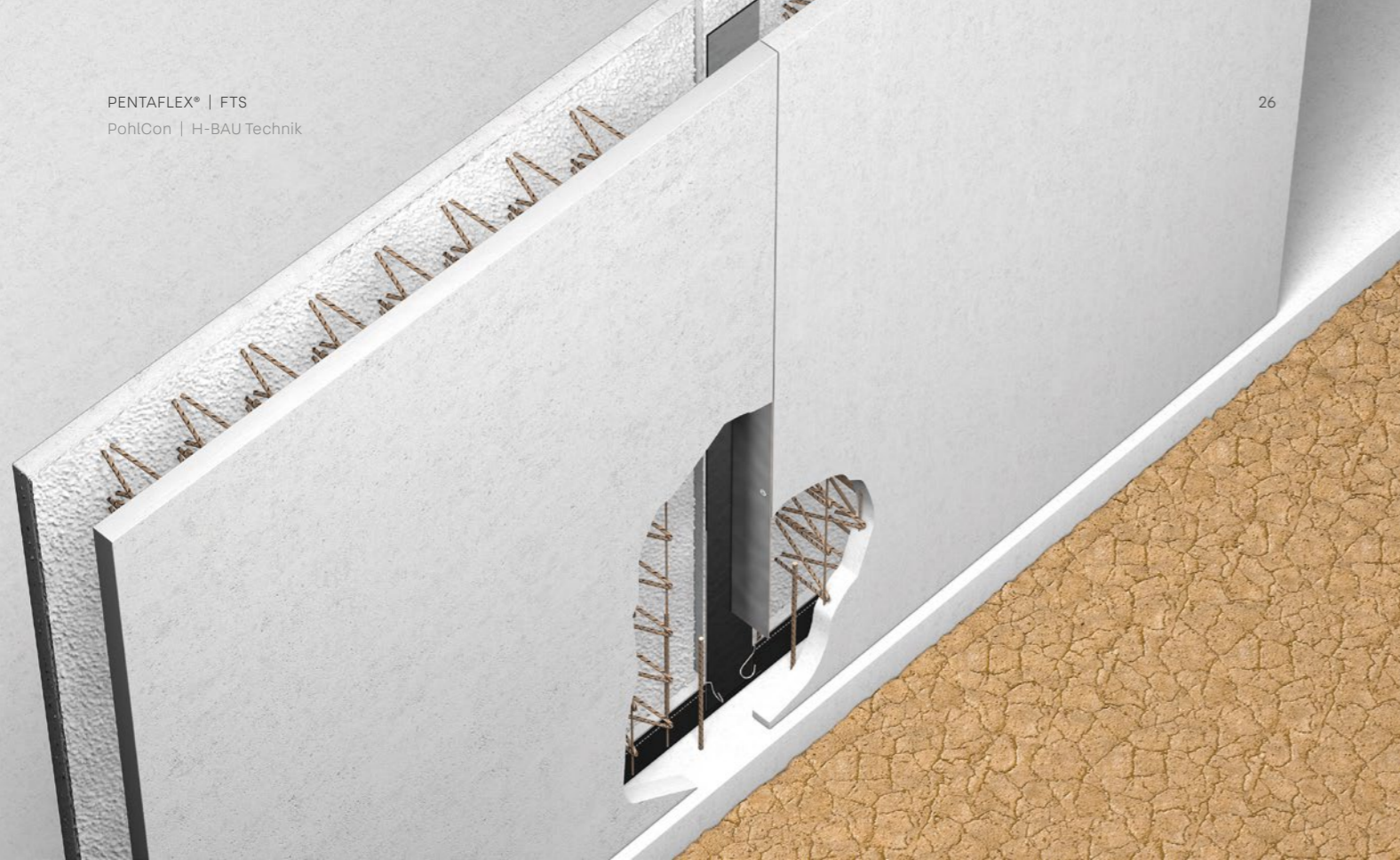

PENTAFLEX® FTS

Element for sealing and creating crack control joints in element walls

The product

PENTAFLEX® FTS crack control elements for walls consist of a seam sheet with the tried-and-tested PENTAFLEX® special coating and a galvanised sheet steel wing. This weakens the concrete cross-section and also allows the skinplate to be attached.

The elements are manufactured as standard in 2.50 m, 2.75 m and 3.00 m lengths. The PENTAFLEX® FTS joint element is available for walls of any thickness. Standard elements for walls 240–250 or 300 mm thick are kept in stock. The elements are supplied ready for installation.

Area of application

PENTAFLEX® FTS crack control elements are used to generate control cracks in element walls. The sealing element seals the resulting crack against water under pressure and not under pressure. FTS elements are designed for sealing vertical joints in prefabricated white tank constructions. The joint seals are also suitable for double-wall construction even at the corner joints.



Benefits

- Approved for use in Europe with ETA-15/0003
- General building code test certificate P-5120/231/09 MPA-BS
- CE mark
- Quick and easy to install on the prefabricated formwork
- Reduced waiting times
- Reliable creation of shrinkage cracks
- Watertight up to 5.0* bar
- PENTAFLEX® special coating resistant to organic effluents
- Easy, secure connection with PENTAFLEX® KB

Technical information

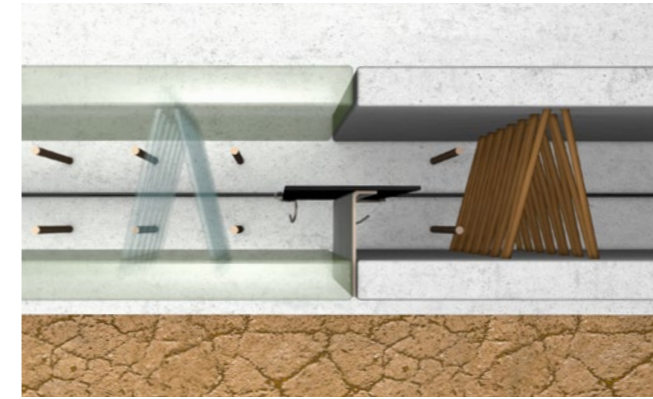

Fig. 1: FTS for straight joints

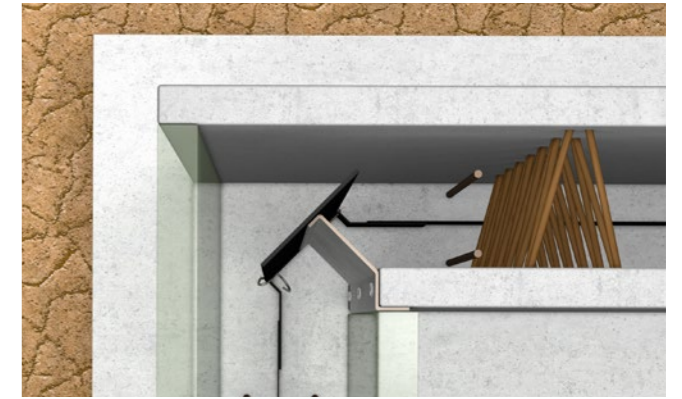
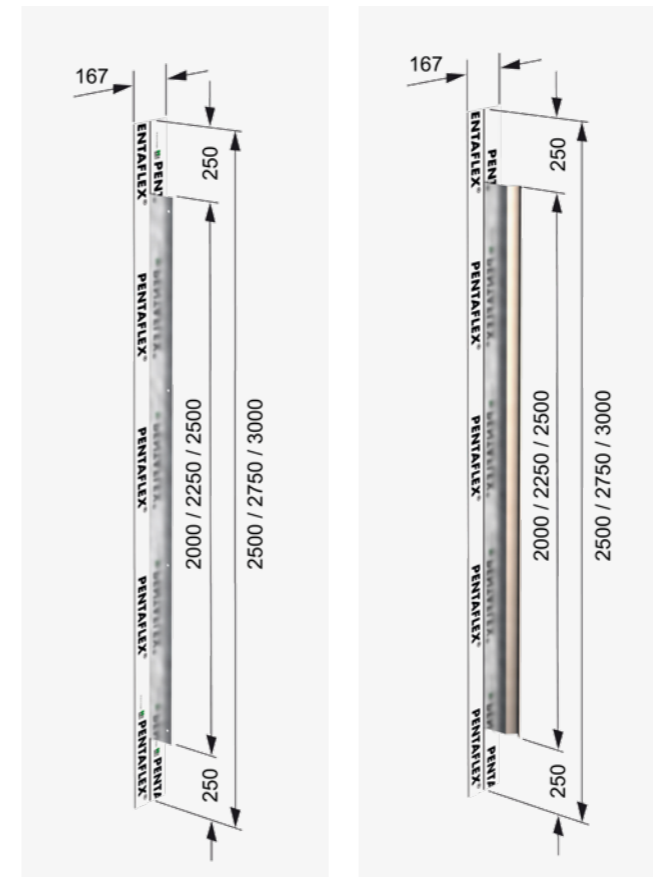

Fig. 2: FTS-Eck for corner joints



Basic information

- PENTAFLEX® KB seam sheet
- Element length: L = 2.50; 2.75; 3.00 m
- Variants for straight slab joints (Fig. 1)
- Variants for slab corner joints (Fig. 2)
- Elements kept in stock for wall thickness 240/250 and 300 mm
- Seam sheet overlap at top and bottom for connection to PENTAFLEX® KB
- Other dimensions available on request



When using PENTAFLEX® FTS Eck corner elements, PENTAFLEX® KB Eck corner elements must be installed in the floor slab.

Ensure that the footing is properly installed:
If the drop height is more than 1 m, a joint mixture (maximum grain ≤ 8 mm) must be used in the footing area at heights ≥ 300 mm to ensure that the concrete is installed without any voids.

Installation instructions

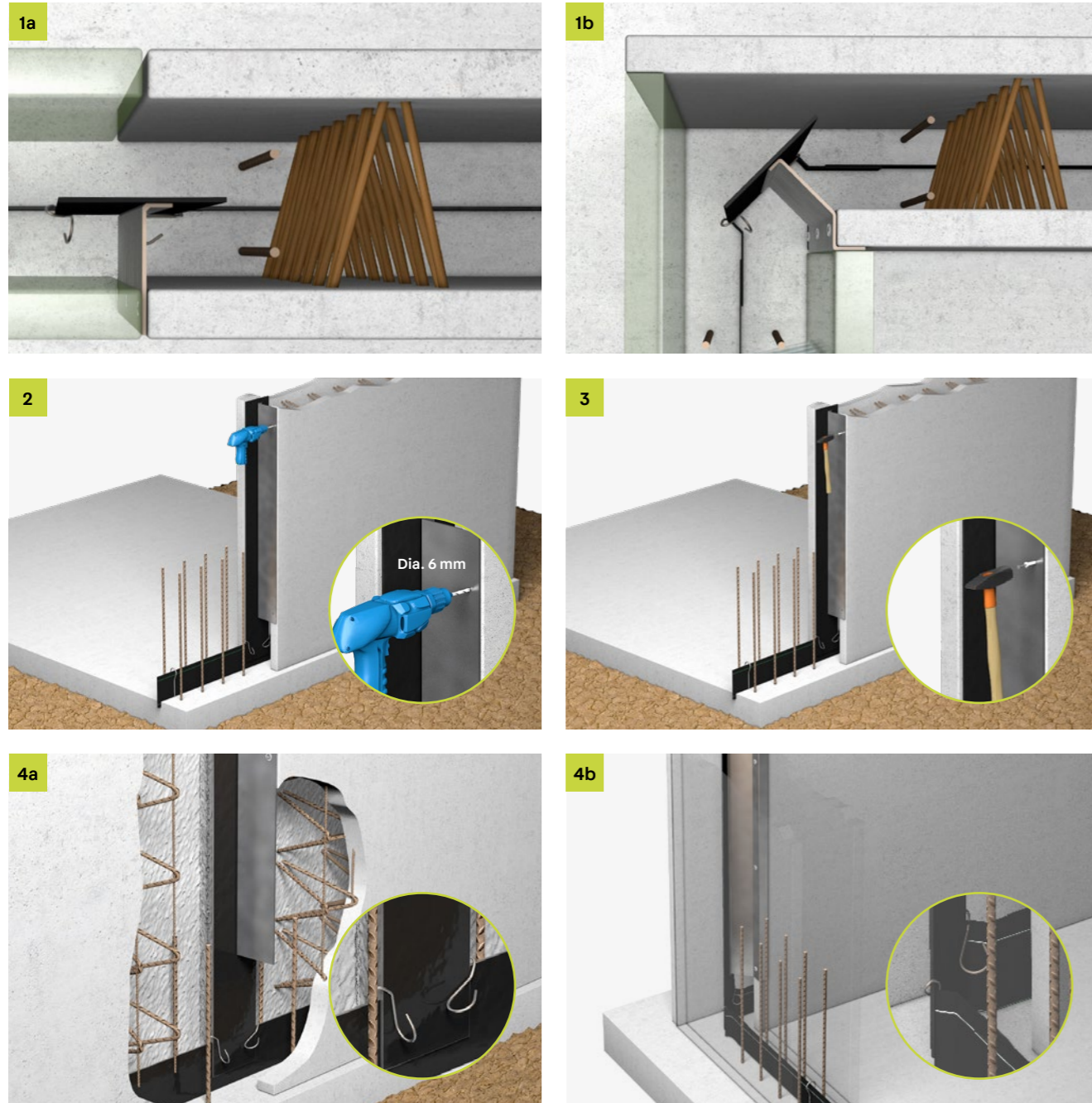

It is essential to use PENTAFLEX® KB Eck corner elements when building with element walls.

Installation process

Example

- A** Determine the installation direction of the element walls.
- B** Position the first wall element. Secure the PENTAFLEX® FTS elements on both faces of the precast component. Connect the PENTAFLEX® FTS to the floor slab with the PENTAFLEX® KB seam sheet.
- C** Position the next wall element. Secure the PENTAFLEX® FTS to the face of the precast component and connect to the floor slab with the PENTAFLEX® KB seam sheet.

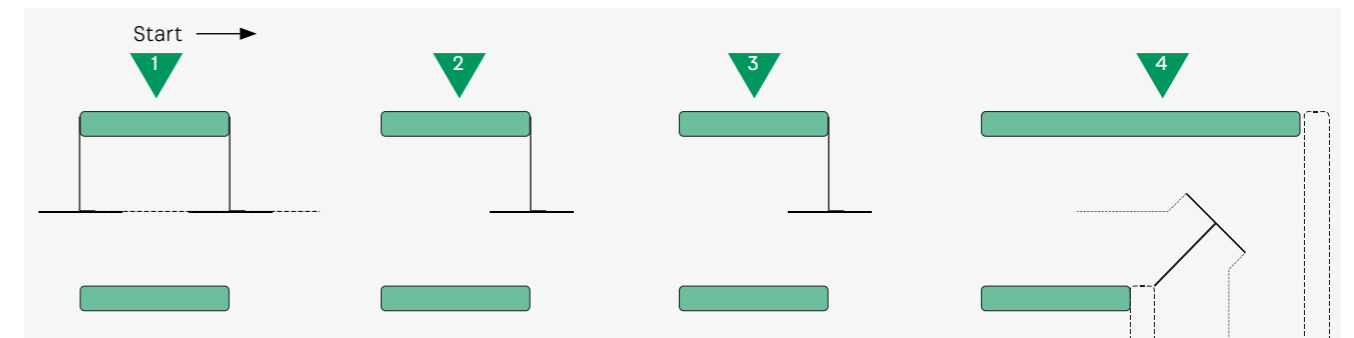

- D** Insert the last wall element carefully between the wall elements already fitted with PENTAFLEX® FTS elements.

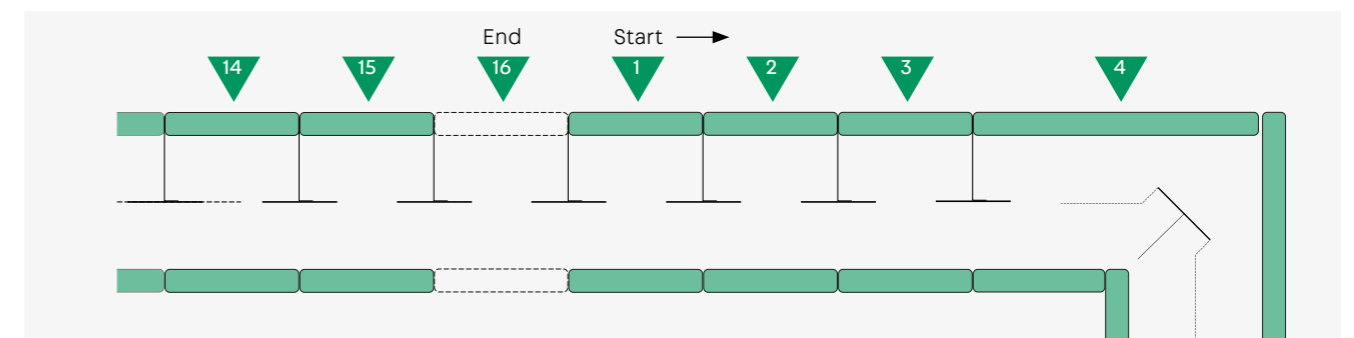

PENTAFLEX® FTS-Fuge for straight joints

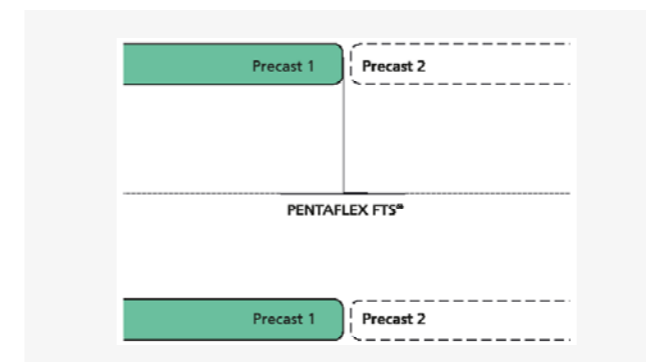

PENTAFLEX® FTS-Eck for corner joints

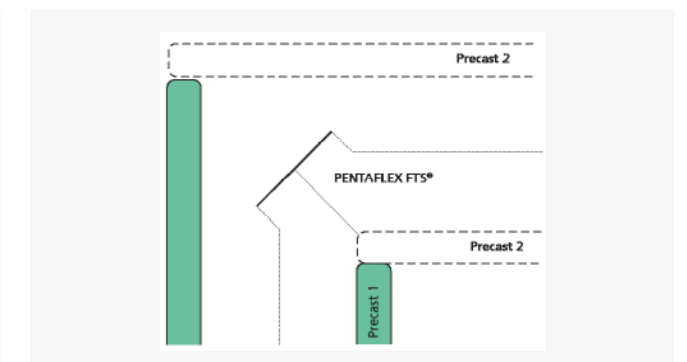

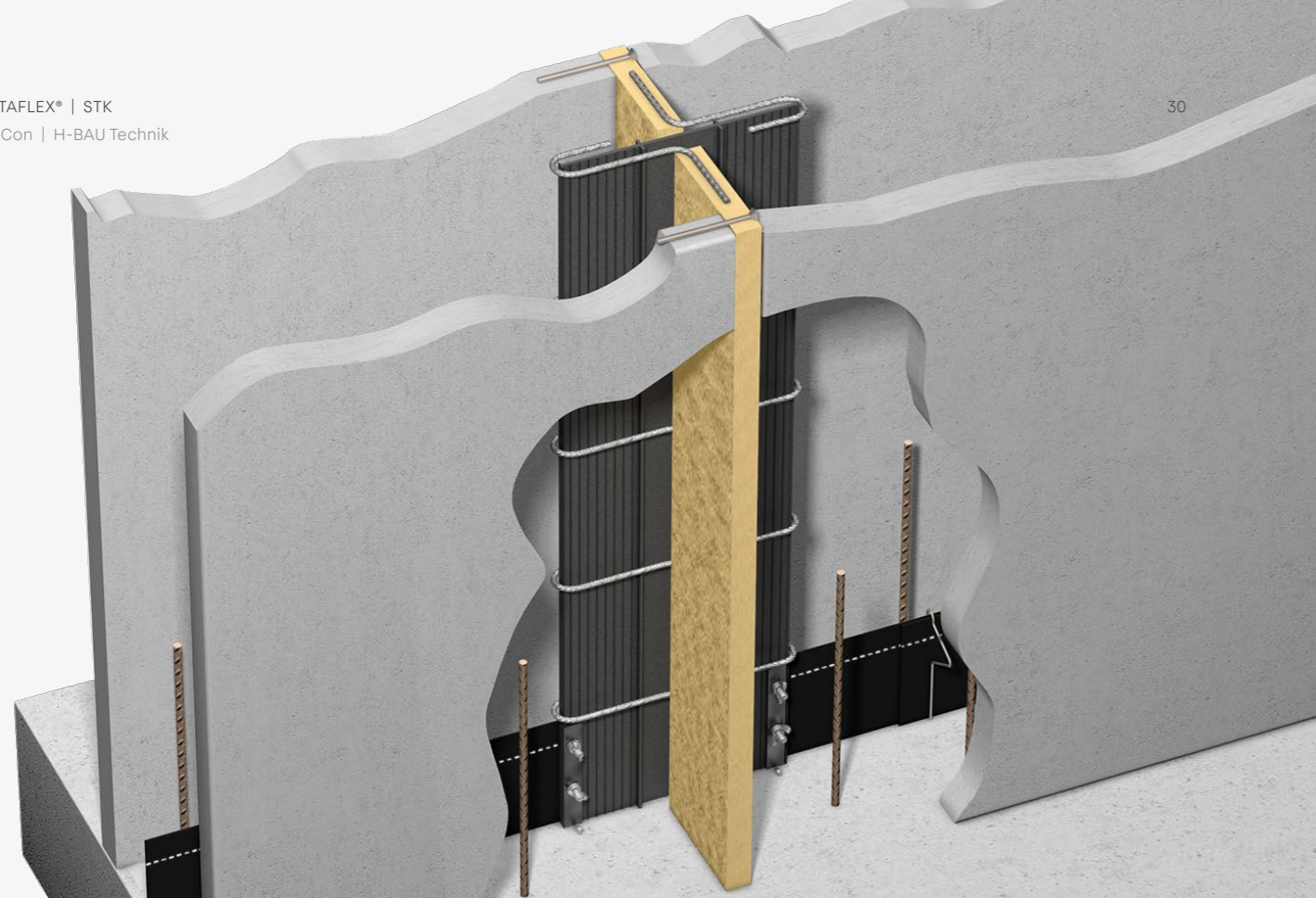

PENTAFLEX® STK

Sound-insulating cage for sealing sound-insulation joints

The product

PENTAFLEX® STK for element walls is a two-part joint cage element made from galvanised structural steel and hydrophobic soft fibreboard. It prevents concrete bridges from forming, thereby acoustically isolating the wall. The integral stirrups guide the joint tape, stop it from drooping during casting, and hence guarantee that the cavity joint is reliably sealed.

PENTAFLEX® SFB is an elastic sound-insulation joint tape with the tried-and-tested PENTAFLEX® coating for use in the bonding area of the floor slab and includes a pre-assembled PENTAFLEX® joint tape connection for connecting to the PENTAFLEX® KB in the base/wall joint.

Area of application

The PENTAFLEX® sound-insulation joint system is predominantly used in terraced or semi-detached houses. It can be used either in element wall constructions or for in-situ concrete construction. The houses are acoustically insulated using the PENTAFLEX® STK sound-insulating cage. The PENTAFLEX® sound-insulation joint tape seals the building joint against water under pressure and not under pressure. This results in a closed joint system as stipulated by the German watertight structure guideline.



Benefits

- Tested for sound insulation
- Quick and easy assembly
- Reliable sound insulation
- Reliable insulation joint seal
- Simple and secure connection with PENTAFLEX® KB joint elements



Improvement in joint insulation value
 $\Delta K_{ij} = 17.2 \text{ dB}$

Technical information

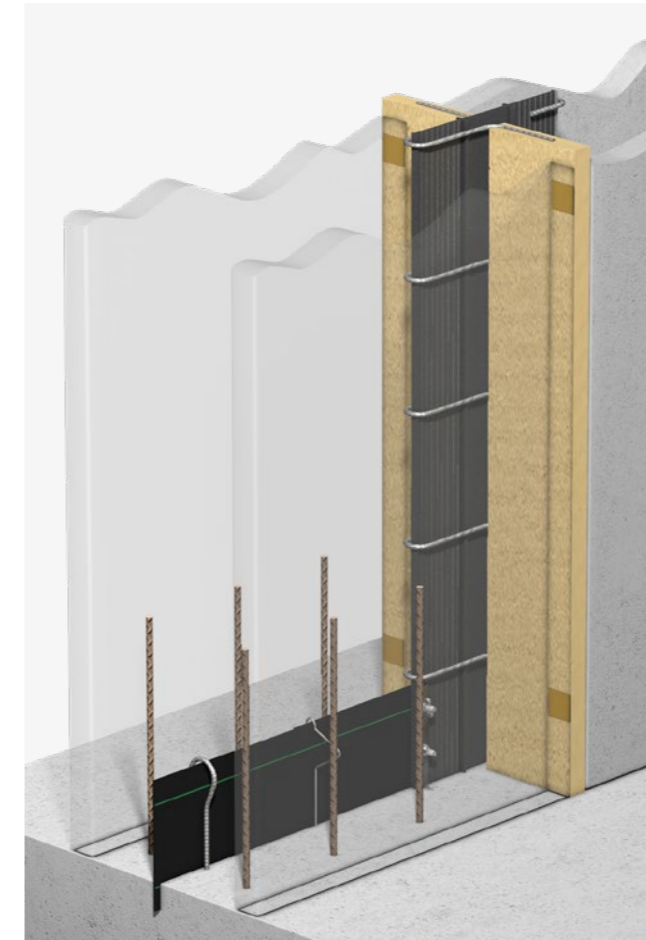

Basic information

The PENTAFLEX® sound-insulation joint reliably performs three tasks:

- Seals the building joint
- Reliably fixes the PENTAFLEX® sound-insulation joint tape in place
- Acoustically decouples the components

It is not necessary to shutter the joint separately. Ensure that the element walls and wall formwork are evenly filled on both sides during casting.

Note

It is advisable to use a surface seal to protect the exterior insulation panel to ensure that sound insulation values remain constant in the long term. Other measures are necessary in the area of the floor slab and the separating walls of the building. The sound-insulating cage can also be used horizontally if the building has a separate floor slab.

System cross section

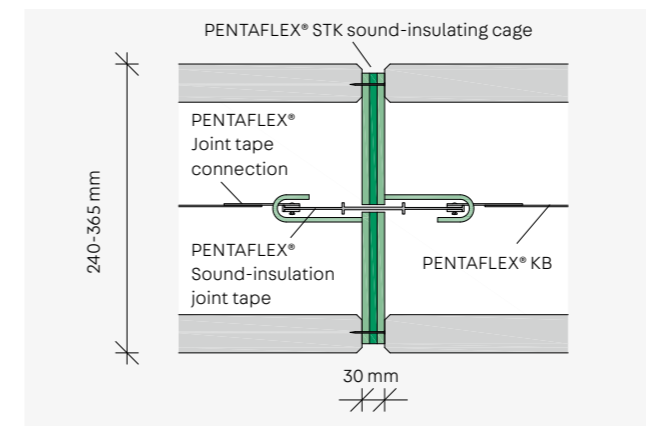

Range



PENTAFLEX® STK sound-insulating cage

- Two-part sound-insulating cage
- Element length: L = 3.00 m
- Pre-assembled, ready for installation
- For wall heights ≤ 2.80 m
- For wall thicknesses 240–365 mm
- Element thickness: 30 mm
- Joint dimension in plan 40 mm

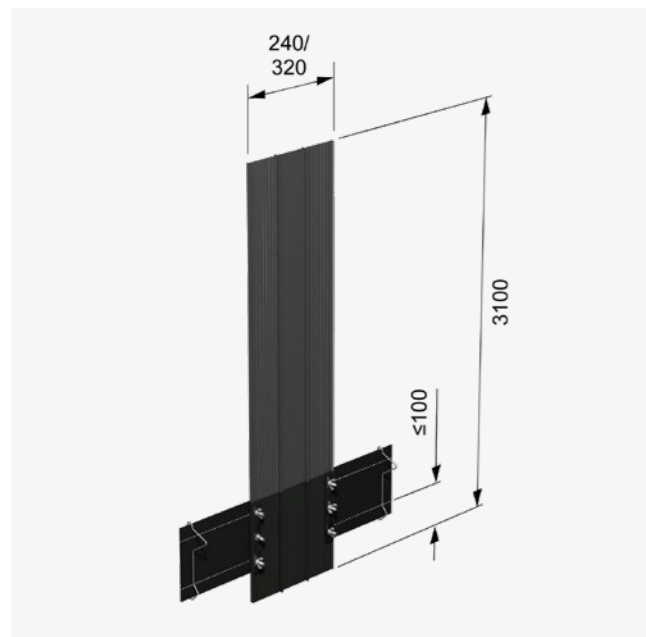

PENTAFLEX® SFB sound-insulation joint tape

- Interior PVC joint tape
- Element length: L = 3.10 m
- Pre-assembled PENTAFLEX® joint tape connection
- PENTAFLEX® coating (approx. 300 mm) in the floor slab connection area
- Delivered with Omega stirrups and joint clips
- For wall heights ≤ 2.80 m
- For wall thicknesses ≥ 240 mm
- Possible tape widths: 240 or 320 mm

 Circumferential sound-insulation joints available on request. Our Application Technology department will be happy to assist you.

Tel: +49 7742 9215-300
Email: technik@h-bau.de

Installation instructions

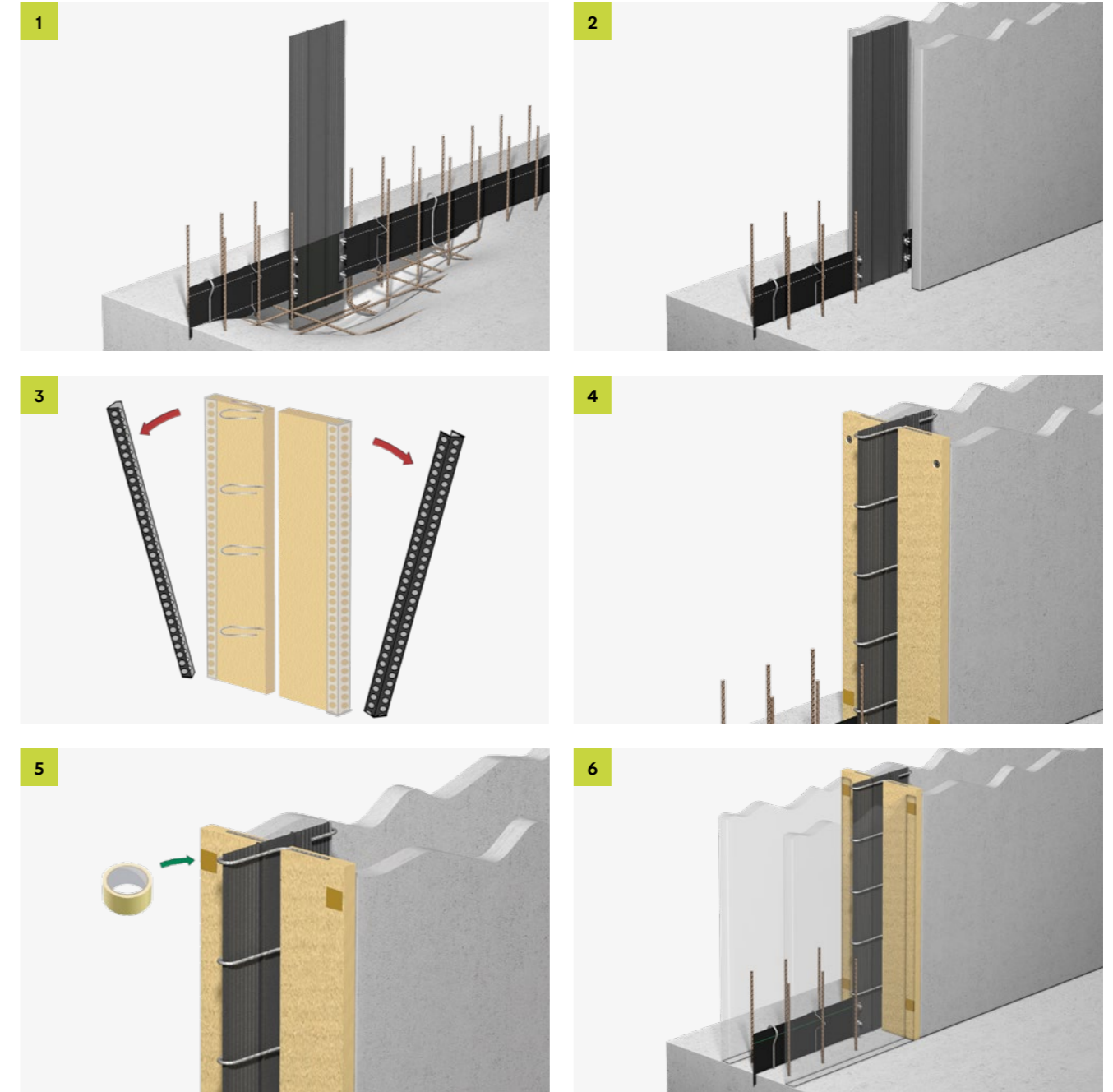

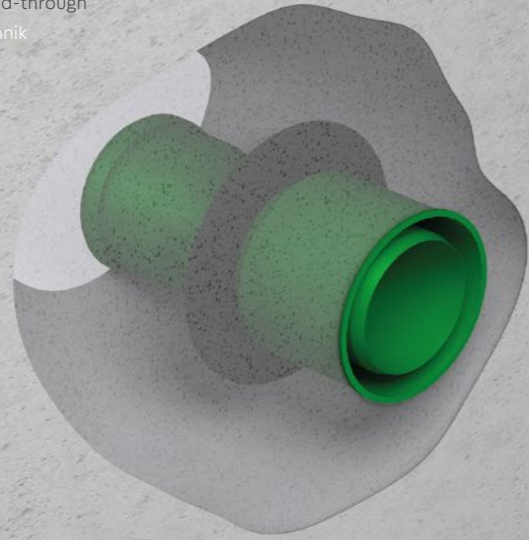

PENTAFLEX® Pipe lead-through

Waterproof wall penetrations

The product

PENTAFLEX® pipe lead-throughs are available in a range of materials. They are equipped with a waterstop with the tried-and-tested PENTAFLEX® coating that ensures that no liquid can leak into the surrounding concrete. They can be used to connect a pipe system inside and outside for passing supply pipes through structural components or collecting surface water on the inside and routing it into wastewater pipes.

Area of application

PENTAFLEX® pipe lead-throughs can be used for any application that requires watertight penetrations (white tanks) for routing supply and waste pipes through structural components.

PENTAFLEX® pipe lead-throughs can be used in both in-situ concrete construction and with prefabricated components. These products are both versatile and reliable, even when used in walls with interior insulation.



Benefits

- Straightforward installation
- Range of materials
- Suitable for commercially available pipe systems
- Very economical and effective

Technical information

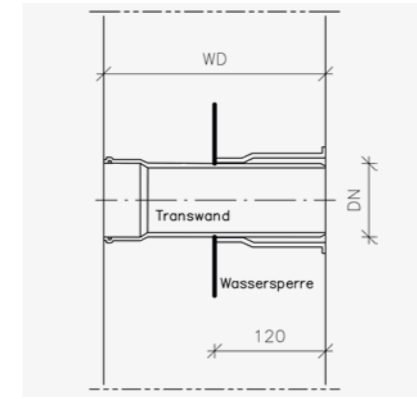
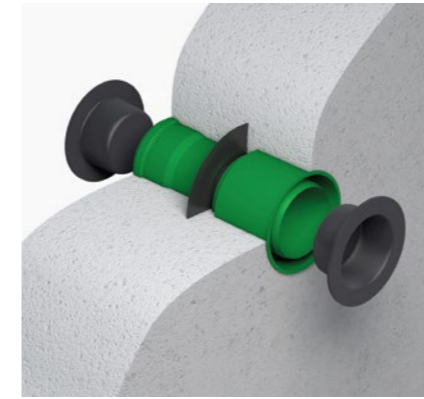

Transwand

For attaching pipe sleeves

- Material: PVC
- DN 110-160
- PENTAFLEX® waterstop
- Wall thickness
Standard: 240, 250, 300 mm

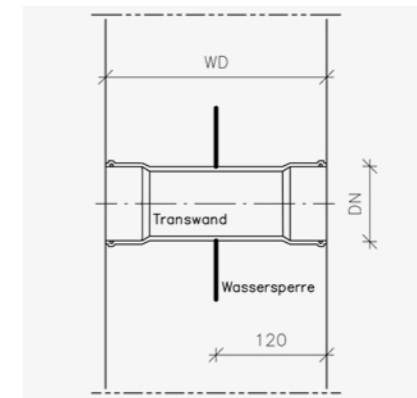
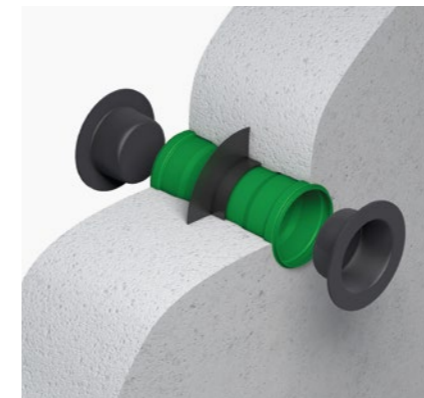

Transwand DM

Double sleeve

- Material: PVC/PP
- DN 110-160
- PENTAFLEX® waterstop
- Wall thickness
Standard: 240, 250, 300 mm
Warning: DN 160 minimum wall thickness 300 mm

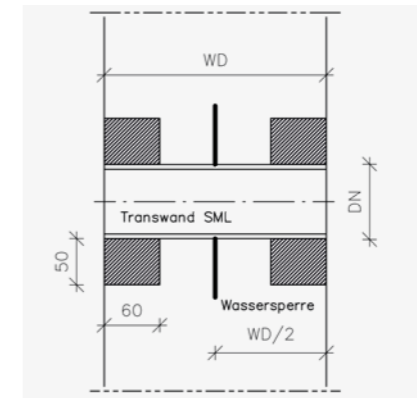

Transwand SML

For connecting SML pipes

- Material: Cast steel
- Polystyrene sleeves
- DN 100-200
- PENTAFLEX® waterstop
- Wall thickness
Standard: 240, 250, 300 mm

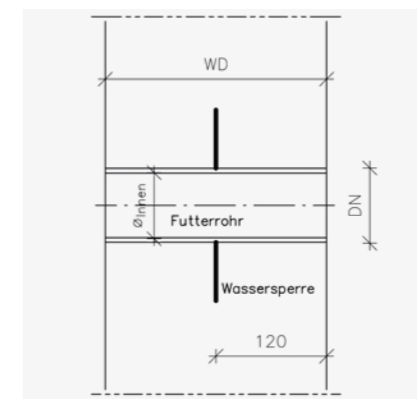
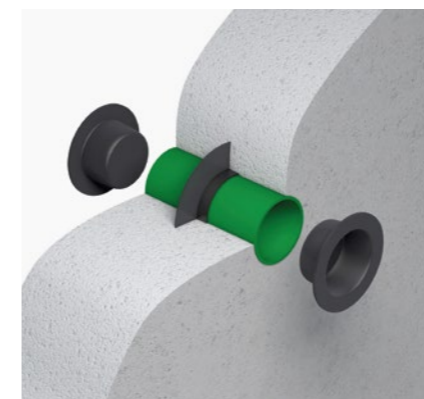

Protective tube

For routing supply pipes through structural components

- Material: PVC/PP
- DN 110-160
- PENTAFLEX® waterstop
- Wall thickness
Standard: 240, 250, 300 mm

Transwand/protective tube

Technical information

Used in walls with interior insulation

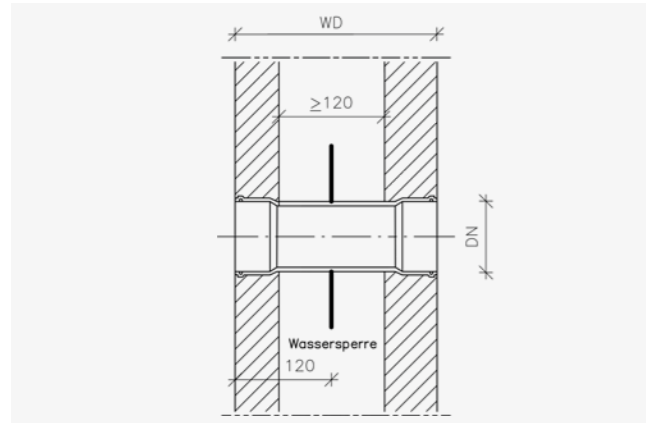

Transwand DM in element wall

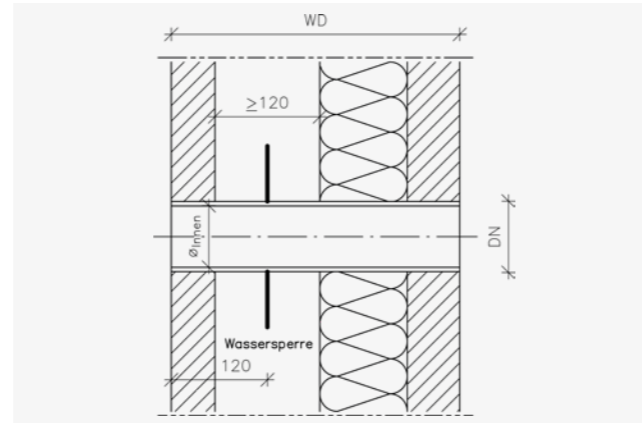

Protective tube in an element wall with interior insulation

Pipe dimensions

DN mm	100		110		125		150		160		200	
∅	Inside	Outside	Inside	Outside	Inside	Outside	Inside	Outside	Inside	Outside	Inside	Outside
Material PP	-	-	103.2	110.0	117.2	125.0	-	-	150.2	160.0	187.6	200.0
Material PVC	-	-	103.6	110.0	118.6	125.0	-	-	152.0	160.0	190.2	200.0
Material SML	103	110	-	-	127	135	152	160	-	-	200	210

Installation instructions

- Remove the marked cover.
- Attach the marked cover (usually to the exterior formwork) with great precision, paying attention to the planned connection direction of the on-site pipelines
- Attach the pipe lead-through to the secured cover
- If necessary, also fix the pipe in place using binding wire
- Remove the protective film from the waterstop
- When closing, press the interior formwork against the second cover of the lead-through
- To connect on-site pipelines, remove the cover on both sides and use the supplied sealing rings



Other materials and dimensions available on request

PENTAFLEX® Floor drain

Technical information



Basic information

For connecting to pipes

- Material: PP
- DN 110
- PENTAFLEX® waterstop
- Attachment piece 150×150 mm, adjustable by 50 mm
- Odour trap (removable)
- Attachment
- Slotted grate 138×138 mm ABS, stainless steel or can be tiled
- Load capacity of 0.3 t depending on design
- Walkable

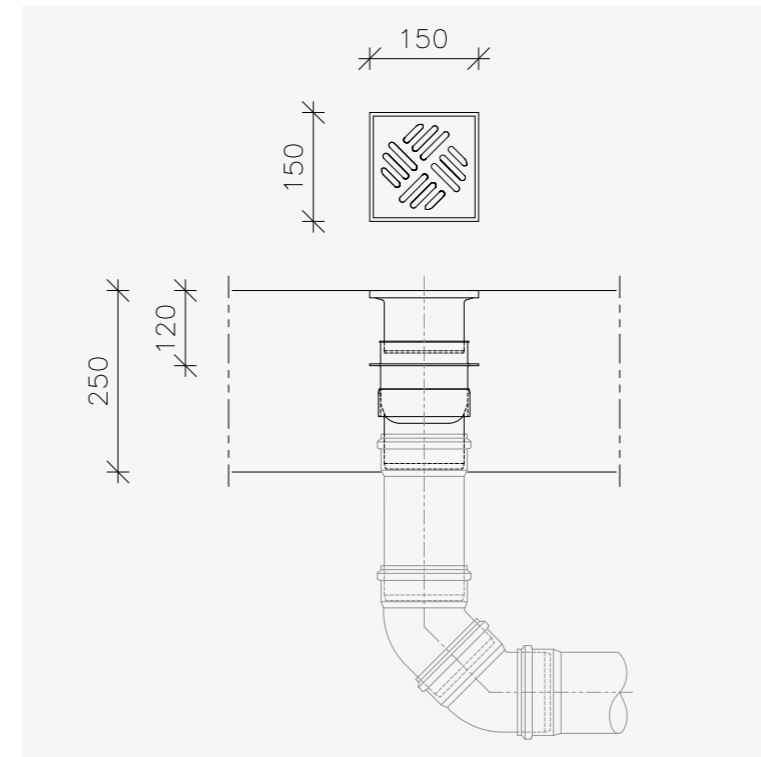

Installation instructions

1. Measure out the position of the floor drain
2. Install the ground pipe ensuring that the outflow is correctly positioned pointing upwards
3. Raise the ground pipe to the required height
4. Insert the floor drain into the ground pipe and fix it in place (using the sealing ring)
5. Remove the protective film from the waterstop
6. Cast the floor slab, check everything is in position
7. Depending on structure of the flooring, the attachment piece can later be pulled out to up to 50 mm further

PENTAFLEX® Floor lead-through

Technical information

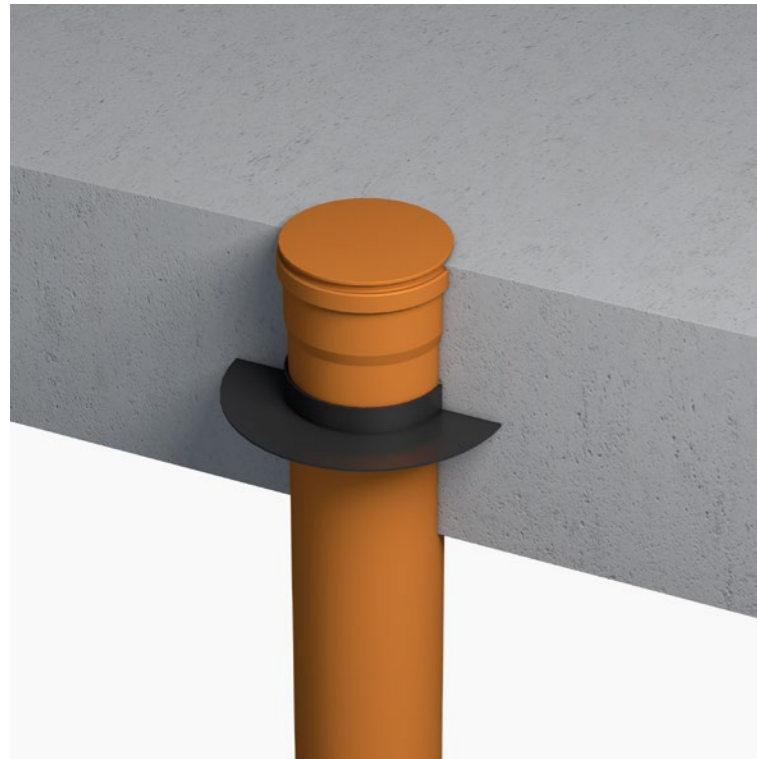

Basic information

For attaching pipe sleeves

- Material: PVC, PP
- DN 110-160
- PENTAFLEX® waterstop
- Pipe length: 500 mm

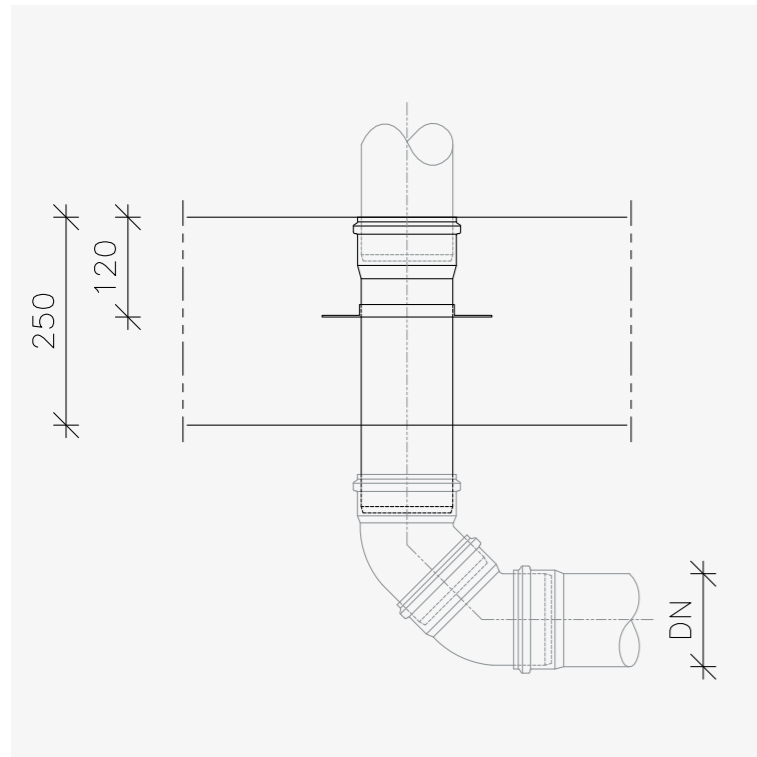

Installation instructions

1. Measure out the position for the floor lead-through
2. Install the ground pipe ensuring that the outflow is correctly positioned pointing upwards
3. Determine the required length of the floor lead-through
4. Trim the floor lead-through, insert it into the ground pipe and fix it in place (using the sealing ring)
5. Insert the cover into the sleeve. Be aware of the risk of contamination.

PENTAFLEX® Roof drain

Technical information



Basic information

For connecting to pipes

- Material: PVC
- DN 110
- PENTAFLEX® waterstop
- Metal mesh basket

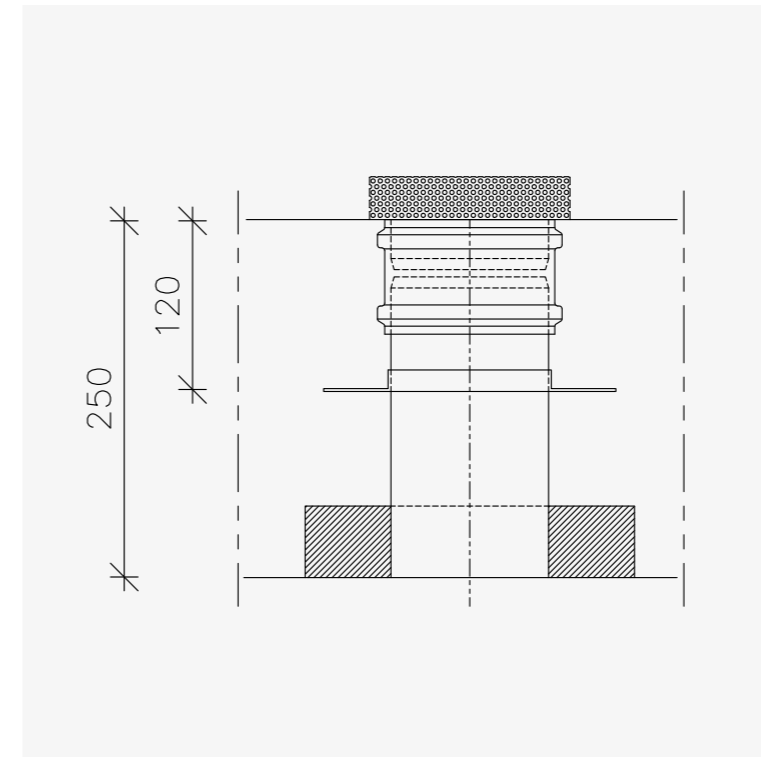

Installation instructions

1. Remove the polystyrene cover.
2. Attach the cover to the formwork precisely
3. Attach the roof drain to the secured cover
4. If necessary, fix the roof drain in place with binding wire
5. Remove the protective film from the waterstop
6. Cast the ceiling, check everything is in position
7. To connect on-site pipelines, remove the cover and use the supplied sealing rings



Technical information

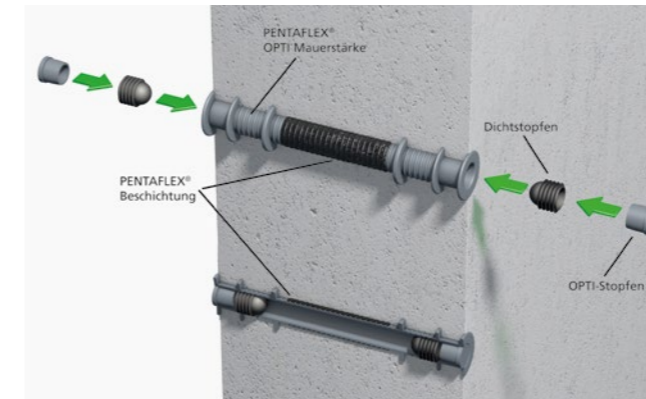

Basic information

- Plastic tie points with integrated waterstops
- Available as standard in lengths of 240 mm, 250 mm, 300 mm, 350 mm, 365 mm and 400 mm
- Inside diameter 22 mm
- Sealing stopper strips included
- Other dimensions available on request

PENTAFLEX® OPTI wall strengthener

Waterproof tie point

The product

PENTAFLEX® OPTI wall strengtheners consist of a plastic tube with an interior diameter of 22 mm and integrated waterstops.

In addition, the wall strengthener is provided with a tried-and-tested PENTAFLEX® coating to ensure a watertight bond between the tie point and the concrete. Sealing stopper strips and OPTI stoppers turn the PENTAFLEX® OPTI wall strengthener into an easily manageable tie point that is resistant to water under pressure.

Area of application

PENTAFLEX® OPTI wall strengtheners are specially designed for use as watertight formwork tie points for watertight concrete structural elements. They are available for all wall thicknesses used in the watertight concrete construction sector.



Benefits

- Tested for watertightness: Up to 5 bar in the direction of stopper insertion
- Tried-and-tested PENTAFLEX® coating for additional reliability
- Can be closed immediately after stripping the formwork
- Install and seal in any weather

Installation instructions

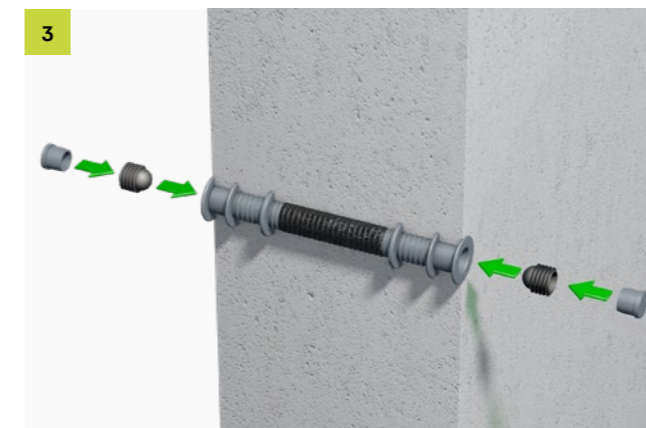
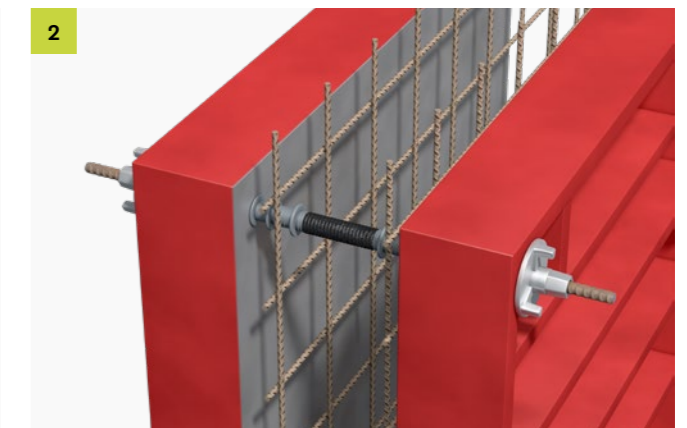
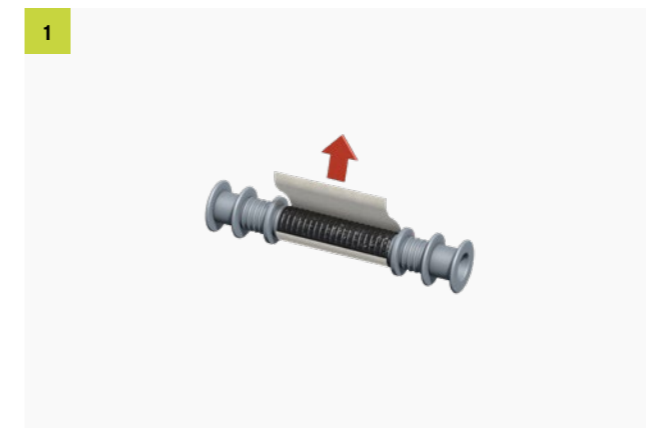

Design and construction

of watertight concrete structures*

Basic principles

Watertight reinforced concrete structures known as "white tanks" have been built for over 30 years to prevent the ingress of water into buildings. Thanks to many years of practice and experience, this method of construction is an economical way of providing protection against water under pressure. The German watertight concrete guideline sets out the generally accepted technical rules and standards for this type of structure.

The watertightness of a structure is defined by its ability to prevent or limit water seepage through concrete, construction joints, crack control joints, expansion joints, assembly elements and cracks.

This means that

- All joints must be sealed
- The concrete must satisfy stringent requirements
- Minimum component thicknesses must be observed
- Separating cracks must be avoided
- Crack widths in structural components must be limited
- The pressure-resistant zones must be of a certain height
- Construction joints, crack control joints and expansion joints must be arranged and formed as planned

Area of application

- The German watertight concrete guideline applies to floor slabs, walls, ceilings (not intermediate ceilings) and roofs
- The German watertight concrete guideline likewise applies to tanks, retaining walls and underground civil engineering structures
- The German watertight concrete guideline does not apply to structures governed by the German additional technical terms of contract and guidelines for civil engineering structures (ZTV-ING), the German additional technical contract conditions for hydraulic (reinforced) concrete structures (ZTV-W), concrete prefabricated garages and containers

Planning tasks

The usage requirements and necessary arrangements for the structure's fitness for purpose and stability are defined and implemented during planning. The project planner is responsible for this.

The following parties are involved

- Designer/architect (coordinator)
- Geotechnical engineer
- Structural engineer
- Contractor (work scheduling)
- Client
- Building physicist
- Work coordinator
- Planning expert (specialist)

The following tasks and measures must be taken into consideration

- Requirements planning
- Type of stress (soil survey)
- Type of usage and start of use
- Component-related design principles
- Structural, concrete-related and construction measures in accordance with the design principle
- Component dimensions
- Planning the joint sealing system
- Planning assembly components and penetrations
- Watertight concrete design
- Documentation of all specifications

Specifications

The German watertight concrete guideline stipulates that water seepage through concrete, joints, assembly components and cracks must be limited.

Stress classes

There are two stress classes. The difference between them lies in whether there is water against the structure or whether there is merely moisture in the soil and/or water flowing down the walls.

Stress class 1	Stress class 2
<ul style="list-style-type: none"> • Constant or occasional water under pressure 	<ul style="list-style-type: none"> • Soil moisture and free-flowing water by the wall

Usage classes

The German watertight concrete guideline distinguishes between two usage classes. These are defined by the intended use, the required indoor climate and the moisture level of the component's surface.

Usage class A	Usage class B
<ul style="list-style-type: none"> • No damp spots caused by water seepage on the side of the component's surface exposed to air • No cracks or joints channelling water 	<ul style="list-style-type: none"> • Damp spots are permitted on the side of the component's surface exposed to air • Temporary and self-healing water-channelling cracks • No accumulation of water on the component's surface
<p>Application examples:</p> <ul style="list-style-type: none"> • Standard for residential buildings and offices • Storage rooms for high-value goods 	<p>Application examples:</p> <ul style="list-style-type: none"> • Single garages, underground car parks • Installation and supply shafts • Building services rooms • Storage rooms with simple requirements

*) Source: German Committee for Structural Concrete (DAFStb) guideline "Watertight structures made of concrete" and DAFStb data sheet 555 Notes on the DAFStb guidelines "Watertight structures made of concrete".

Design principles

Separating cracks must be avoided

Force stresses in concrete that can result in the formation of water-channelling separating cracks can be avoided using suitable structural, concrete-related and construction measures.

Specifying the width of separating cracks

This principle controls and/or predefines the crack width by providing extra reinforcement for the concrete structure. Water seepage is limited by the use of self-healing concrete.

Specifying the width of separating cracks in combination with sealing measures

The third design principle draws on the minimum requirements for the theoretical widths of separating cracks set out in DIN EN 1992-1-1. Water-channelling cracks are subsequently sealed using the planned sealing measures.

Concrete-related and design requirements

When selecting a suitable concrete, the requirements for the exposure class that applies to the structural component (specified in DIN EN 1992-1-1/NA) must be observed. Furthermore, the requirements for concrete with a high resistance to water penetration (specified in DIN EN 206-1 and DIN 104-2) must be taken into account.

Sufficient workability can be guaranteed by using consistency class F3 or softer. When designing watertight components with minimum component thicknesses, an equivalent water/cement ratio of ≤ 0.55 must be used for stress class 1. For walls, the maximum particle size that may be used is ≤ 16 mm. If the drop height is more than 1 m, or if using element walls with a minimum wall thickness, a joint mixture (maximum grain ≤ 8 mm) must be used in the footing area at heights ≥ 300 mm to ensure that the concrete is installed without any voids.

Component thickness

The following minimum thicknesses of structural components are specified in the German watertight concrete guideline as a table, based on many years of experience with in-situ concrete and prefabricated components.

The minimum thickness and construction of the structural components must therefore be selected so that the concrete structural components can be properly cast, taking the concrete covering, the required reinforcement layers, the joint seals and the assembly elements into account. All the other required properties must be fulfilled besides being load-bearing and having a sealing function. In addition to the recommended minimum dimensions, there are special requirements for the clear inside dimension b_{wji} . This is to ensure that casting is possible and to allow professional installation of the inner joint seal. This requirement applies to in-situ concrete walls between the layers of reinforcement and to element walls without reinforcement in the in-situ concrete topping added between the inside surfaces of the prefabricated slabs.

Minimum inside dimension:

- For a maximum particle size of 8 mm $b_{wji} \geq 120$ mm
- For a maximum particle size of 16 mm $b_{wji} \geq 140$ mm
- For a maximum particle size of 32 mm $b_{wji} \geq 180$ mm

If the resulting component thicknesses are larger than the minimum dimensions given in the table below, the resulting component thicknesses take precedence.

Type	Stress class	Minimum thickness in mm		
		In-situ concrete	Element walls	Prefabricated components
Walls	1	240	240 (120 ^b)	200
	2	200	240 ^a (120 ^b)	100
Floor slab	1	250	-	200
	2	150	-	100
Roofs without thermal insulation	1	200	240 (180 ^b)	180
Roofs with thermal insulation	1	180	220 (160 ^b)	160

^a This can be reduced to 200 mm if particular concrete-related and construction measures are taken.

^b Minimum values for the in-situ concrete topping. Section 7.1 (2) of the German watertight concrete guideline applies to watertight concrete. Additional requirements for the clear inside dimensions set out in Section 7.2 (3) of the guideline may need to be met if additional reinforcements and inside joint seals are used.

Calculations and dimensions

Effects

- Direct effects (loads)
- Indirect effects (temperature, shrinkage, settling)
- Chemical and physical effects (classification into exposure classes)

Bedding conditions

- Subsoil, insulation, subbase, sliding layers

Force

- From fully or partially impeded deformation
- From atmospheric factors

Certification

- Proof of watertightness is an additional proof of fitness for purpose as defined by DIN 1045-1, section 5.4.1, paragraph 2.

Basics

Verification depending on the design principle. For bending cracks resulting from loads and forces, it is necessary to prove for usage class A, stress class 1, that the pressure zone height (x) fulfils the condition $x \geq 30$ mm and $\geq 1.5 D_{max}$, where D_{max} is the maximum aggregate particle diameter.

Alternative: limit the width of bending cracks (w_k in line with table 2)

Proof of design principle A

The characteristic tensile strength of the concrete must not exceed the central tensile stress at any time.

Proof of design principle B

See the table of theoretical separating crack widths for usage class B and the design principle B if water seepage is to be limited by self-healing cracks.

Pressure gradient h_w/h_b^a	Maximum head of water h_w^a	Permissible crack width w_k^b
10	3.0 m	0.20 mm
> 10 to ≤ 15	6.0 m	0.15 mm
> 15 to ≤ 25	10.0 m	0.10 mm

^a h_w = head of water in m; h_b = component thickness in m

^b Crack self-healing must not be factored in to the calculation in regions with aggressive waters with > 40 mg/l CO₂ (lime-dissolving carbonic acid) or with pH < 5.5

Proof of design principle C

Theoretical crack width $w_k = 0.30$ mm with XC2/XC3

Reinforcement and design rules

The layout of the reinforcement in the structural components must be designed to allow the fresh concrete to be cast and compacted correctly. Watertight components of stress class 1 must be manufactured with two layers of rebar mesh composed of criss-crossing reinforcing elements. This is not required for prefabricated components of stress class 2. The construction joints must be defined by the planner and presented as a draft design. In accordance with the defined stress and usage class, all joints in watertight components must be permanently protected by a continuous and consistent joint sealing system that is impermeable to water.

Crack control joints are caused by sufficiently weakening the concrete cross-section (at least 1/3 of the structural component's thickness) and must be sealed accordingly.

Special crack control elements guarantee that both requirements are met, making them suitable for structures of usage class A. Element wall joints should generally be designed as crack control joints.

Joint seals

Only products whose intended purpose is verified by a proof of usability certificate may be used for joint seals in watertight components. All of the joint seals that engage with the concrete must be precisely placed according to the design, connected to the joints and forcefully and permanently secured in position prior to casting the concrete.

Sealing system	Regulations in line with German watertight concrete guideline
Joint tapes in line with DIN 7865 and DIN 18541	Usage in line with DIN 18197
Uncoated seam sheets in line with DIN EN 10051	Usage in line with German watertight concrete guideline, section 10.2
Unregulated construction products: <ul style="list-style-type: none"> • Joint tapes in line with factory standard • Combination construction joint tapes • Exterior strip-shaped joint seals • Coated seam sheets • Leaktight pipes • Pressure-injected injection hoses • Swellable joint inserts 	Proof of usability is required ETA - European Technical Assessment abP - German building code test certificate (Allgemeines bauaufsichtliches Prüfzeugnis)

Construction

General information

Reinforcement work, concrete casting, curing and construction supervision must be carried out in accordance with DIN EN 13670 in conjunction with DIN 1014-3.

Spacers and formwork anchors

The spacers and formwork anchors used must not affect the watertightness of the structure locally (see DBV fact sheets on spacers and supports in line with EC 2).

Manufacture, delivery and assembly of prefabricated components and semi-prefabricated components and casting in-site concrete

- Surfaces against which concrete is cast in-situ must be of a quality that guarantees a void-free bond
- This means that the entire bonding surface must have a rough grain
- The average surface roughness depth must be at least 1.5 mm
- Proper assembly must be ensured
- Construction joints must be cleaned of contamination before assembly
- Element wall panels must be elevated by at least 30 mm
- The inside surfaces must be sufficiently pre-wetted before casting the concrete core
- The surface temperature of the element wall must be above 0°C
- The core concrete is laid in layers, generally 500 mm high
- Observe the concreting speed specified by the manufacturer
- Ensure that the concrete is carefully compacted
- All measures must be suitably documented

Sealing cracks and repairing defects

Cracks, leaking joints and permeability in the concrete structure must be sealed as described in the DAfStb guidelines on protecting and repairing concrete components.

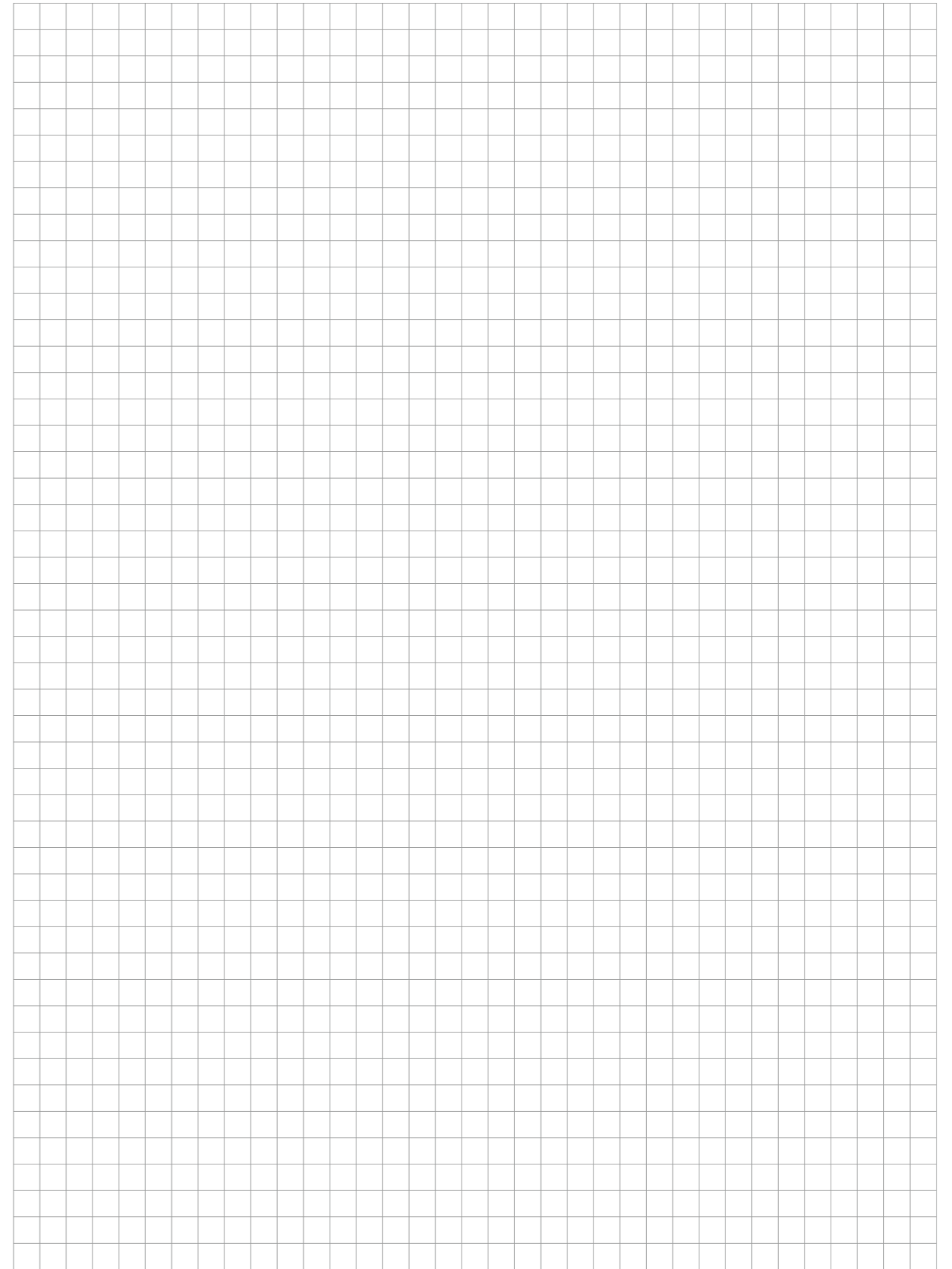
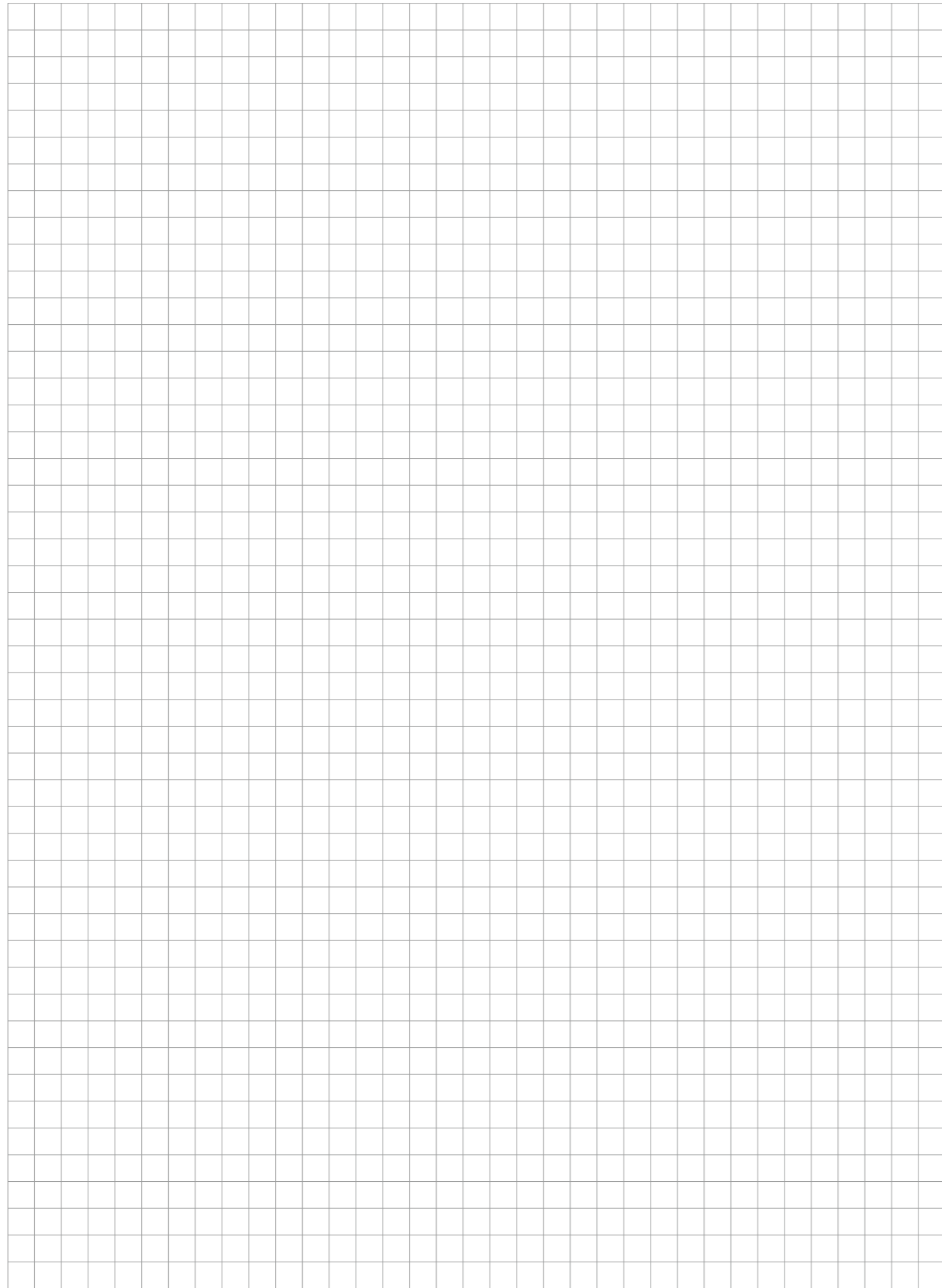

Our synergy concept for your benefit

With us, you benefit from the collective experience of three established manufacturers, who combine products and expertise in a comprehensive range. That is the PohlCon synergy concept.



Full-service consulting

Our extensive network of consultants is available to answer all your questions about our products on site. From planning to use, you can enjoy personal support from our qualified employees.



Digital solutions

Our digital solutions provide targeted support in planning with our products. From tender texts to CAD details and BIM data, right through to modern software solutions, we offer customized support for your planning process.



7 fields of application

We think in terms of holistic solutions. This is why we have combined our products into seven fields of application, where you can benefit from their synergy and the overall PohlCon product portfolio.

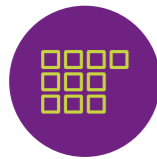

10 product categories

In order to find the right product in our extensive range even faster, we have divided our products into ten product categories. This way you can navigate unerringly between our products.



Individual solutions

No series product on the market is suitable for your project? We realize unique construction projects and exceptional challenges with the many years of expertise of the three manufacturing brands.



Errors and technical changes reserved. Reprinting and any electronic reproduction only authorised with our written permission. All previous documents lose their validity with the publication of this printed matter.

PohlCon GmbH

Nobelstr. 51
12057 Berlin
Germany

T +49 30 68283-04
F +49 30 68283-383

www.pohlcon.com