

# JORDAHL<sup>®</sup> JDA punching shear reinforcement

Technical information



# Table of contents

<b>JORDAHL® Punching shear reinforcement</b>		<b>Installation</b>	<b>20</b>
European Technical Assessment (ETA)	4	<b>Service</b>	<b>24</b>
National technical approval (abZ)	4		
Introduction to punching shear reinforcements	5		
Benefits of JORDAHL® JDA punching shear reinforcements	6		
Standard element product range	8		
Design in line with ETA-13/0136	10		
Schematic diagram	14		
Sample calculation	171		
JORDAHL® EXPERT JDA punching shear reinforcement	18		

# JORDAHL® Punching shear reinforcement

Approvals and certificates

## European technical assessment (ETA)

The JORDAHL® double-headed anchor is a punching shear reinforcement element. The Deutsche Institut für Bautechnik (DIBt) (German institute for structural engineering) awarded JORDAHL the European Technical Assessment (ETA-13/0136) thanks to the continuous improvements made to the product. The ETA evaluates the technical and qualitative properties of products. It is based on a Europe-wide procedure for assessment that is fully valid in more than 30 countries and allows you to also plan your international projects with maximum reliability.

## National technical approval (abZ)

Currently, not all construction products have a harmonised technical specification (EAD). This is required in order to obtain a European Technical Assessment (ETA). However, we still want to guarantee our customers the assurance of the well-known JORDAHL® quality to give them a verified basis on which to plan their projects. To this end, the corresponding abZ confirms that JORDAHL® products, such as JORDAHL® JDA-S shear reinforcement (Z-15.1-268), can be safely installed and applied.



### Downloads

Are you interested in our certificates and approvals? You can download them from [www.pohlcon.com/downloads](http://www.pohlcon.com/downloads) > Proofs of application

## Introduction to punching shear reinforcements

Point-supported flat slabs are the ideal solution for making optimum use of large halls or warehouse buildings.

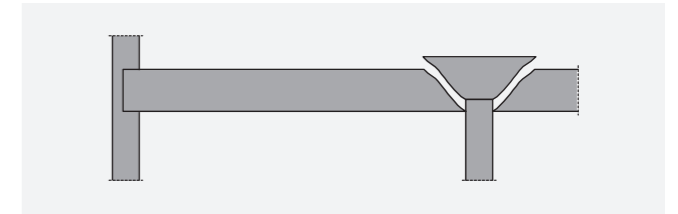

Figure 1: Punching shear situation

The problem of punching shear in areas around column heads (Fig. 1) was recognised even in the early days of concrete construction. Ceilings held up by large, mushroom-shaped capitals (Fig. 2) were introduced in around 1900 to eliminate the need for main and secondary beams obstructing the space.

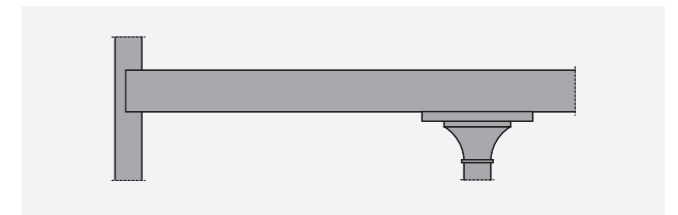

Figure 2: Ceilings held up by large, mushroom-shaped capitals

Only a short time later, the Kahn steel reinforcement system (Fig. 3) came into use for tensile reinforcement. It had upturned wings that resisted transverse forces in the ceiling support area. The inventor of the Kahn steel reinforcement system, Julius Kahn, and his brother, the famous architect Albert Kahn, enjoyed great success with this product in the reinforced steel concrete.

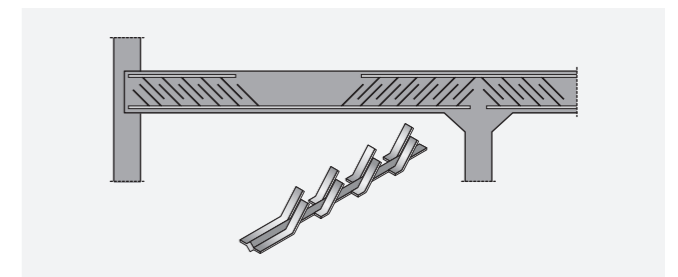

Figure 3: Kahn steel reinforcement system

Using conventional methods it is often not possible to achieve thin slabs and wide spans between supporting columns or large slab breakthroughs close to the supporting column heads (Fig. 4). As an alternative, Andrä et al. have developed a solution in which the area at risk of punching shear is dowelled using dowel strips.

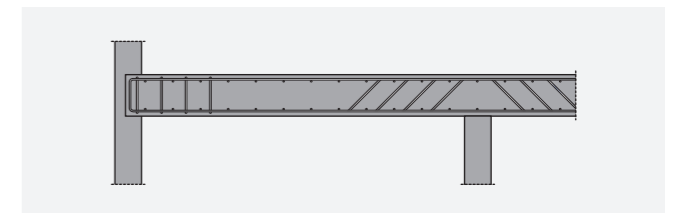

Figure 4: Flat ceiling with stirrups and rebar bent diagonally upwards

This solution was further developed into punching shear anchoring made of reinforcing steel, each with two swaged heads (Fig. 5). Following the introduction of the Eurocode, the assessment process had to be fundamentally revised. The current European Technical Assessment ETA-13/0136 corresponds to the latest state of knowledge and is successfully applied in multiple sectors.

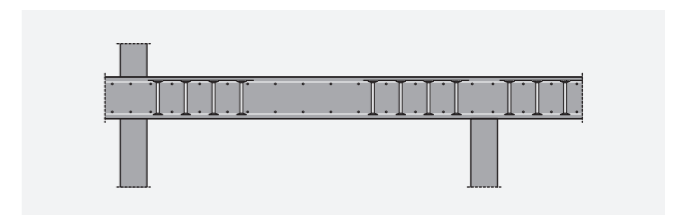

Figure 5: JORDAHL® JDA punching shear reinforcement with double-headed anchors

## Benefits of JDA punching shear reinforcements

JORDAHL® JDA punching shear reinforcement is used to transfer high shear forces and to ensure optimum usage of space. It is ideal for use in flat slabs and foundations and minimises formwork and rebar work. It can increase resistance to punching shear by 50% compared to foundations without punching shear reinforcement and by as much as 96% compared to ceiling slabs without punching shear reinforcement.

- European Technical Assessment for static and dynamic loads (ETA-13/0136)
  - Concrete strength range C20/25 to C50/60
  - Calculation according to the Eurocode safety concept
  - Precise calculation of asymmetrical load transfers for all column positions
  - Defined transition between punching shear and transverse force resistance
  - Higher load-bearing capacity than slabs and foundations without punching shear reinforcement
  - Suitable for slabs 18 cm thick and greater
- Flat lower ceiling surface
  - Unobstructed area below the ceiling for installing fittings
  - Optimum use of space
  - Higher load-bearing capacity than conventional reinforcement techniques
  - Low concrete slab depths
- Standard elements simply lined up for easier anchor strip installation
  - Minimal formwork required
  - Quick and easy installation from above or below
  - Flexible production to suit specific static requirements

The JORDAHL® JDA punching shear reinforcement consists of double-headed anchors connected by a flat strip. Double-headed anchors secure the transition between punching shear and transverse force resistance.

### Material

The double-headed anchors are made of B500B round reinforcing steel, the flat strip is made of construction steel. Delivery subject to confirmation.

### Technical information

The JORDAHL® JDA punching shear reinforcement can be flexibly produced to suit the specific static requirements. The double-headed anchors are available in diameters  $d_A = 10, 12, 14, 16, 20$  and  $25$  mm (for product range, see Seite 8). The diameter of the head  $d_k$  is always triple the diameter of the shaft  $d_A$ . This ensures near slip-free anchoring of the compression area and tension area.

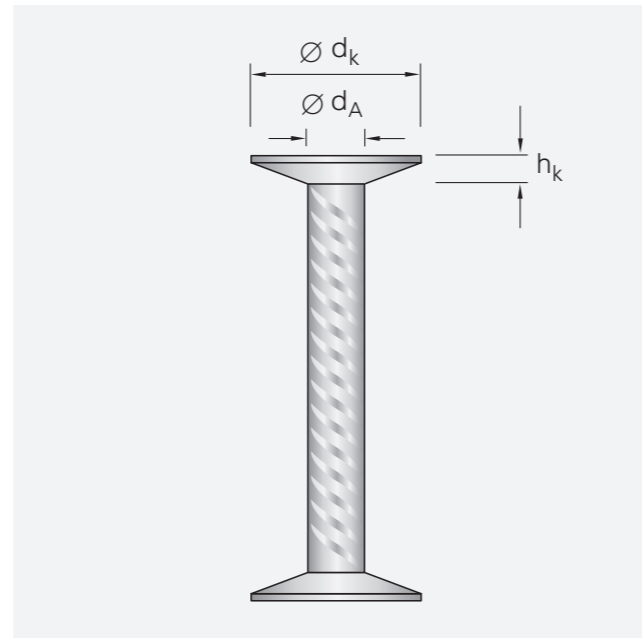

Ribbed, double-headed anchor

$d_A$ mm	$d_k$ mm	$h_k$ mm	$A$ mm <sup>2</sup>	$F_{RD}$ kN
10	30	5	79	34.1
12	36	6	113	49.2
14	42	7	154	66.9
16	48	7	201	87.4
20	60	9	314	136.6
25	75	12	491	213.4

$d_A$  Anchor diameter  
 $d_k$  Head diameter  
 $h_k$  Min. head thickness  
 $A$  Anchor cross section  
 $F_{RD}$  Load-bearing capacity

### Elements

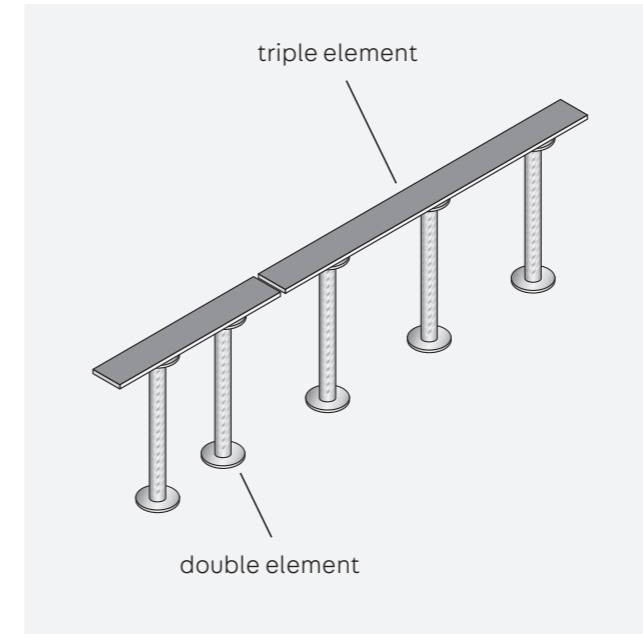

Optimised elements (separate elements)

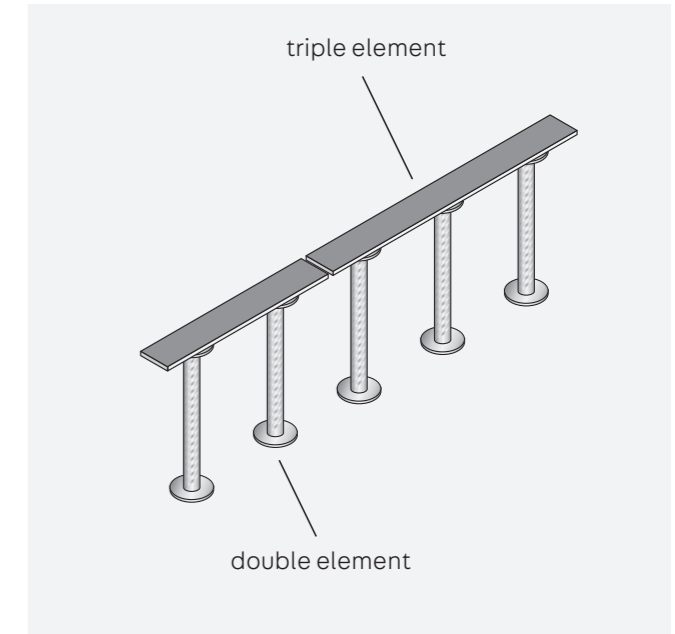

JDA standard elements (separate elements)

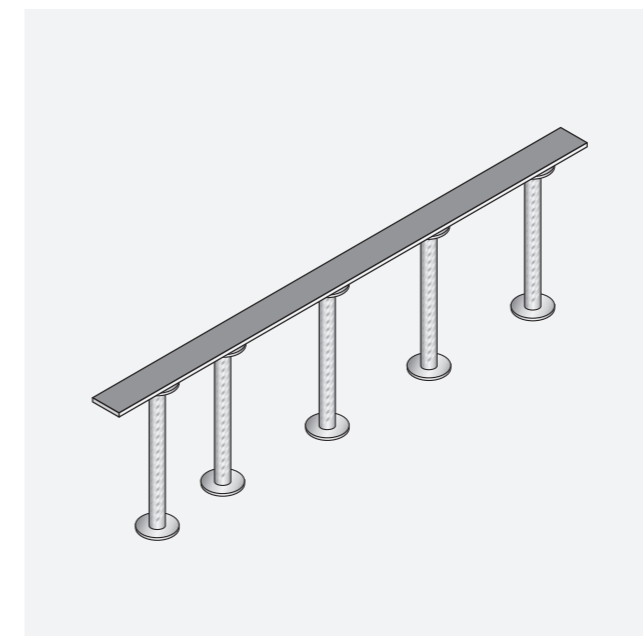

Optimised elements (continuous)



JDA standard elements (continuous)

## Standard element product range

### Welded JDA element – product range<sup>1)</sup>

Anchor length $h_A$ in mm	For anchor diameter $d_A$ in mm											
	10		12		14		16		20		25	
	2 anchors	3 anchors	2 anchors	3 anchors	2 anchors	3 anchors	2 anchors	3 anchors	2 anchors	3 anchors	2 anchors	3 anchors
125												
135	200											
145	200	300										
155	220	330	220	330								
165	240	360	240	360		360						
175	240	360	240	360	240	360						
185	260	390	260									
195	280	420	280	420	280	420	280	420				
205	300	450	300	450	300	450	300	450				
215	300		320	450	320	450	320	450				
225			340	480	340	480						
235			340	510	340	510	340	510	340			
245			360	540	360	540	360	540	360	540		
255			360		360	540	360	540	360	540		
265					380	570	380	570				
275					400	600	400	600	400	600		
285					400	600	400	600	400	600		
295					380		420		420	630		
305					420		420		420	630		
315							440	660	440	660	440	660
325							440		440			
335							480		480		480	720
345							480		480		480	
385							500	750	500		500	
435							520		520		520	
585											560	840
											640	960
											860	

Standard range On request 200  $l_L$  = strip length

JDA, double element, 2 anchors

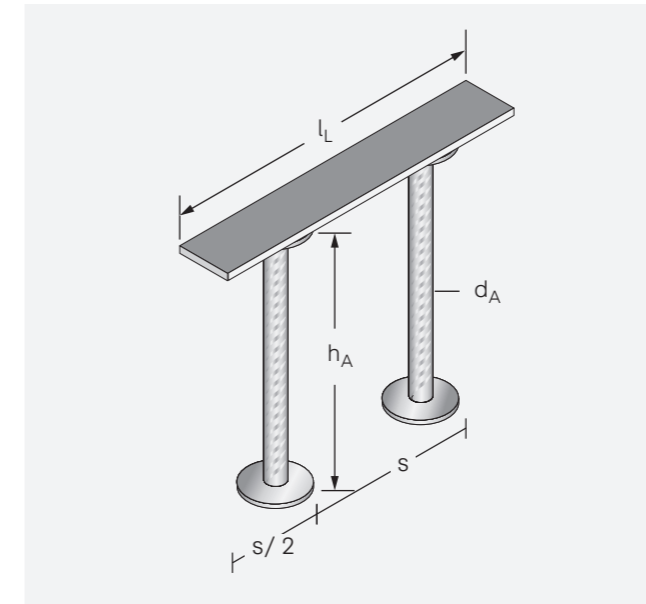

JDA, triple element, 3 anchors

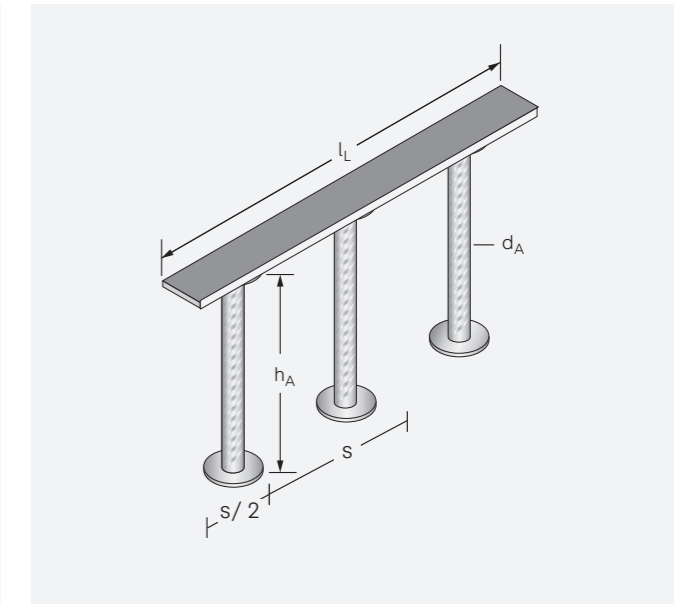

### JDA-FT-KL for precast slabs – product range<sup>1)</sup>

	For anchor diameter $d_A$ mm			
	10	12	14	16
Anchor length $h_A$ mm minimum	125	125	135	155
	↓	↓	↓	↓
	In 10-mm steps			
Anchor length $h_A$ mm maximum	315	335	365	405

### Single elements for JDA – product range<sup>1)</sup>

	For anchor diameter $d_A$ mm					
	10	12	14	16	20	25
Anchor length $h_A$ mm minimum	125	125	135	155	185	215
	↓	↓	↓	↓	↓	↓
	In 10-mm steps					
Anchor length $h_A$ mm maximum	5505	5505	5505	5505	5505	5505

<sup>1)</sup> Additional anchor lengths available on request.

## Design in line with ETA-13/0136

The basic principle when designing elements to resist punching shear is the clear separation of flat slabs and

foundations. Design is regulated by European Technical Assessment ETA-13/0136.

### Summary of verifications

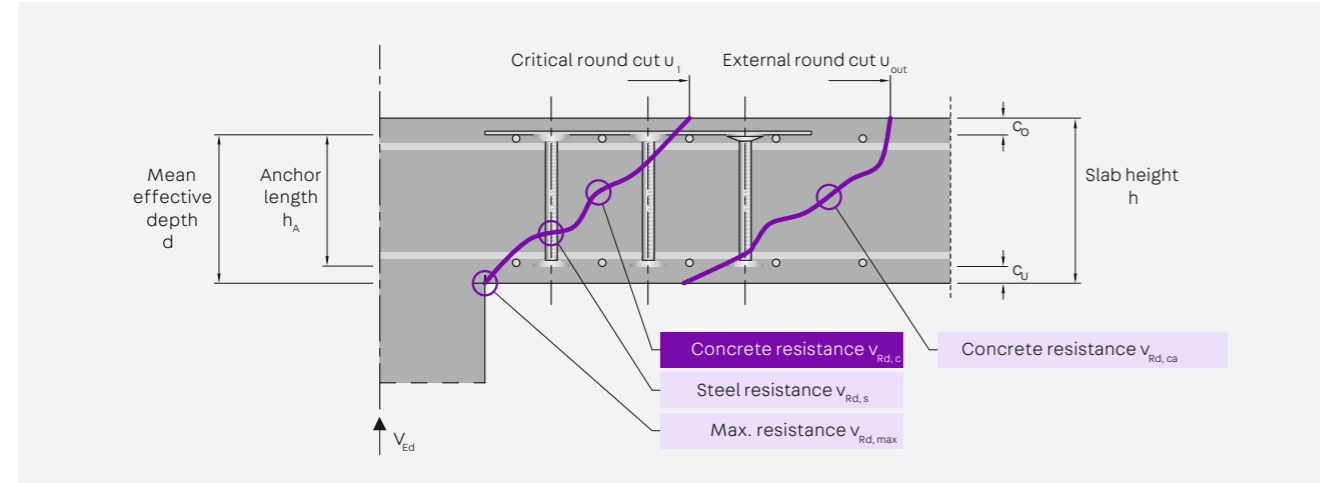

### Round cut-outs

#### For flat slabs

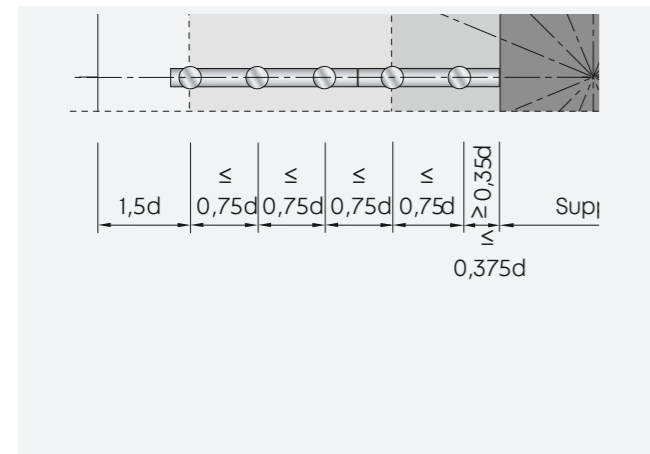

#### For foundations

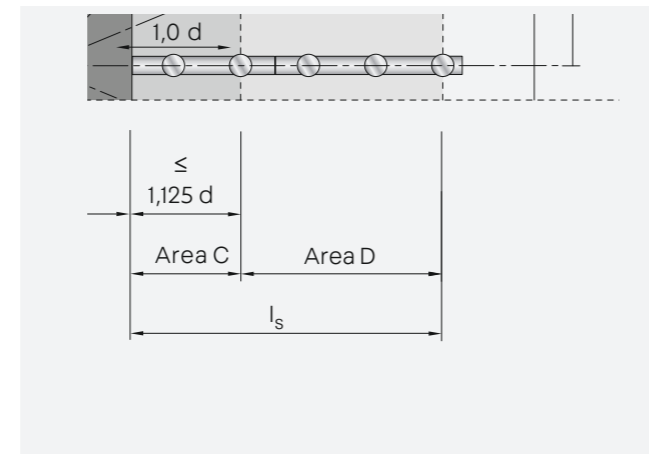

**Conditions:**  $u_0 \leq 12d$  |  $h \geq 180 \text{ mm}$  |  $0.5 \leq a/b \leq 2.0$  for rectangular columns

For columns at the edge and in corners, round cut-outs must be made perpendicular to the free edge (see example on Seite 15). However, the smallest critical round cut-out is the definitive measurement.

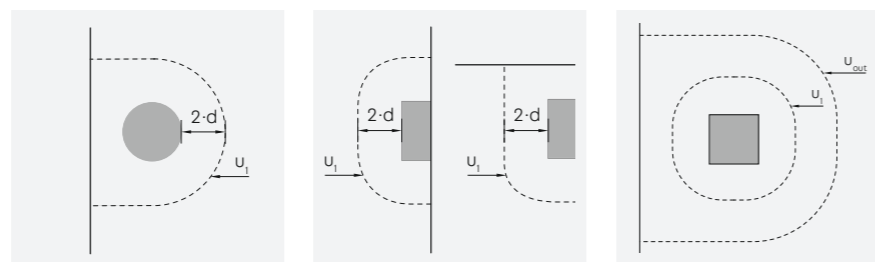

## Design load

### For flat slabs

$$v_{Ed} = \frac{\beta \times V_{Ed}}{u_i \times d} \text{ [N/mm}^2\text{]}$$

### For foundations

$$v_{Ed} = \frac{\beta \times V_{Ed,red}}{u_i \times d} \text{ [N/mm}^2\text{]}$$

$$V_{Ed,red} = V_{Ed} - \sigma_{0d} \times A_f = V_{Ed} \left( 1 - \frac{A_f}{A_c} \right) \text{ [kN]}$$

$\sigma_{0d}$ : ground pressure  
 $A_f$ : foundation contact area; for foundation slabs, the area delimited by the zero moment points running in the radial direction

### Load increase factor

Simplified values can be used for  $\beta$  column span ratios in adjacent fields in the range of 0.8,  $l_1/l_2$ , 1.25.

Alternatively, or if the column span ratio is higher than 25%, the more accurate method based on a fully plastic shear stress distribution specified in EN 1992-1-1 can be used. Procedures using a reduced critical round cut-out must not be used.

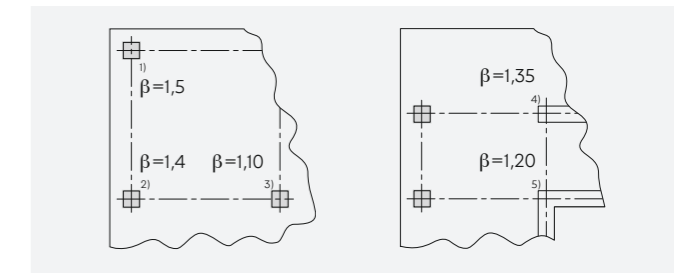

<sup>1)</sup> Corner column, <sup>2)</sup> Edge column, <sup>3)</sup> Interior column, <sup>4)</sup> Wall end, <sup>5)</sup> Wall corner

## Punching shear resistance without punching shear reinforcement

### For flat slabs

$$v_{Rd,c} = C_{Rd,c} \times \kappa \times (100 \times \rho_l \times f_{ck})^{1/3} \geq v_{min} \text{ [N/mm}^2\text{]}$$

### For foundations

$$v_{Rd,c} = C_{Rd,c} \times \kappa \times (100 \times \rho_l \times f_{ck})^{1/3} \times \frac{2d}{a_1} \geq v_{min} \times \frac{2d}{a_1} \text{ [N/mm}^2\text{]}$$

Scale factor  $\kappa = 1 + \sqrt{\frac{200 \text{ mm}}{d}} \leq 2,0$

Longitudinal reinforcement ratio  $\rho_l = \sqrt{\rho_{lx} \times \rho_{ly}} \leq \begin{cases} 0,5 \times f_{cd} / f_{yd} \\ 0,02 \end{cases}$

Minimum resistance  $v_{min} = \frac{0,0525}{\gamma_c} \times \sqrt{\kappa^3 \times f_{ck}}$  für  $d \leq 600 \text{ mm}$   
 $= \frac{0,0375}{\gamma_c} \times \sqrt{\kappa^3 \times f_{ck}}$  für  $d > 800 \text{ mm}$

### Empirical factor – flat slabs

$$C_{Rd,c} = \frac{0,18}{\gamma_c} \text{ für } u_0 \geq 4d$$

$$C_{Rd,c} = \frac{0,18}{\gamma_c} (0,1 \times \frac{u_0}{d} + 0,6) \geq \frac{0,15}{\gamma_c} \text{ für } u_0 < 4d$$

### Empirical factor – foundations

$$C_{Rd,c} = \frac{0,15}{\gamma_c} \text{ für gedrungene Fundamente mit } a_x \leq 2,0 d$$

$$C_{Rd,c} = \frac{0,18}{\gamma_c} \text{ für schlanke Fundamente mit } a_x > 2,0 d$$

## Punching shear resistance with double-headed anchors

### For flat slabs

$$V_{Rd,max} = 1.96 v_{Rd,c} N/mm^2$$

### For foundations

$$V_{Rd,max} = 1.50 v_{Rd,c} N/mm^2$$

## Design in area C or 0.8d

### For flat slabs

$$V_{Rd,sy} = m_c \times n_c \times \frac{d^2 \times \pi \times f_{yd}}{4 \times \eta} \quad [kN]$$

### For foundations

$$V_{Rd,sy} = f_{yd} \times A_{s,0.8d} \quad kN$$

**Slab thickness factor:**  $\eta = 1.0$  for  $d \leq 200mm$   
 $\eta = 1.6$  for  $d \geq 800mm$

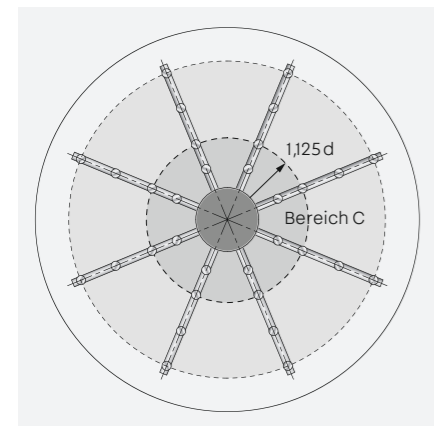

$A_{s,0.8d}$ : Steel cross-sectional area of double-headed anchor in area 0.8d

$f_{yd}$ : Design yield strength of double-headed anchor

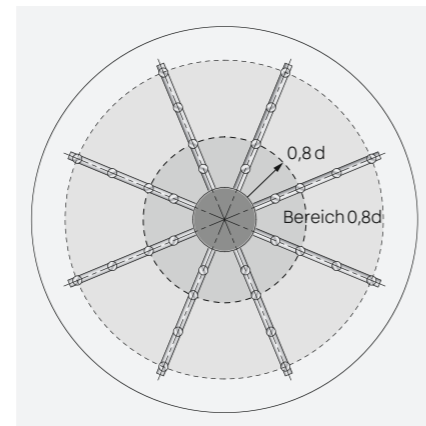

## External round cut-out

$$v_{Rd,ca} = \frac{0,15}{\gamma_c} \times \kappa \times (100 \times \rho_l \times f_{ck})^{1/3} \geq v_{min} \quad [N/mm^2]$$

### Reduced load increase factor:

Interior columns, wall ends, wall corners	Edge columns	Corner columns
$\beta_{red} = \beta \geq 1,10$	$\beta_{red} = \frac{\beta}{1,2 + \beta/20 \times l_s/d} \geq 1,10$	$\beta_{red} = \frac{\beta}{1,2 + \beta/15 \times l_s/d} \geq 1,10$

### For flat slabs

$$u_{out} = \frac{\beta_{red} \times V_{Ed}}{v_{Rd,ca} \times d}$$

### For foundations

$$u_{out} = \frac{\beta_{red} \times V_{Ed,red}}{v_{Rd,ca} \times d}$$

$$V_{Ed,red} = V_{Ed} - \sigma_{od} \times A_{out} = V_{Ed} \left( 1 - \frac{A_{out}}{A_F} \right) \quad [kN]$$

## Permissible anchor spacings

### For flat slabs

- The first anchor is between 0.35 d and 0.5 d from the column
- The radial anchor spacing must not exceed 0.75 d
- The maximum spacing of the anchors in a tangential direction at a distance of 1.0 d from the column must be  $\leq 1.7$
- The tangential anchor spacing in area D must not exceed 3.5 d

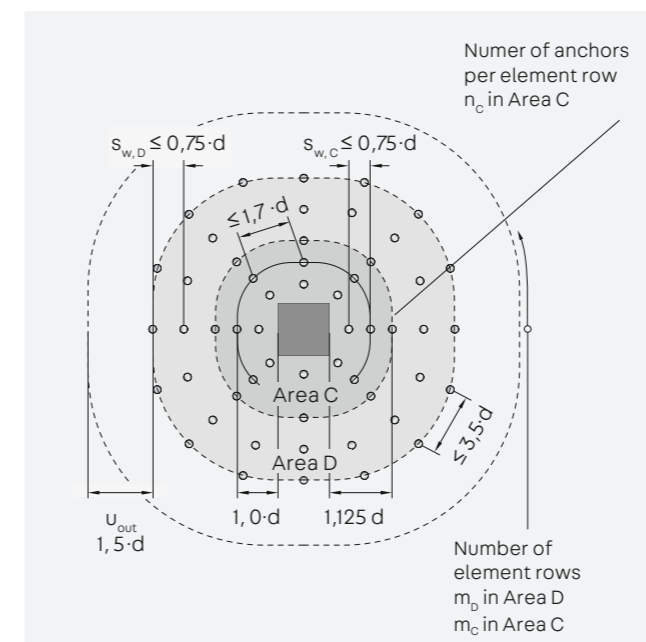

### For foundations

- The first anchor is 0.3 d and the second anchor 0.8 d from the column
- Radial anchor spacing must not exceed 0.75 d for slim and 0.5 d for compact foundations
- Tangential anchor spacing must not exceed 2.0 d

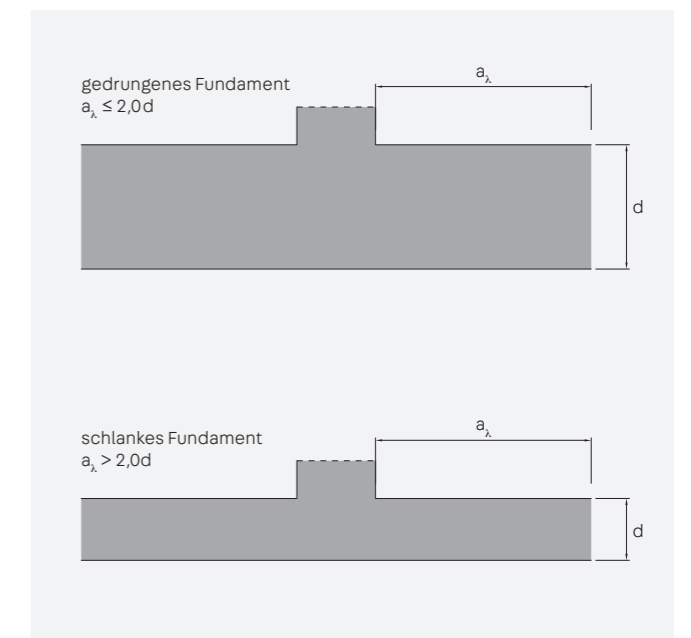
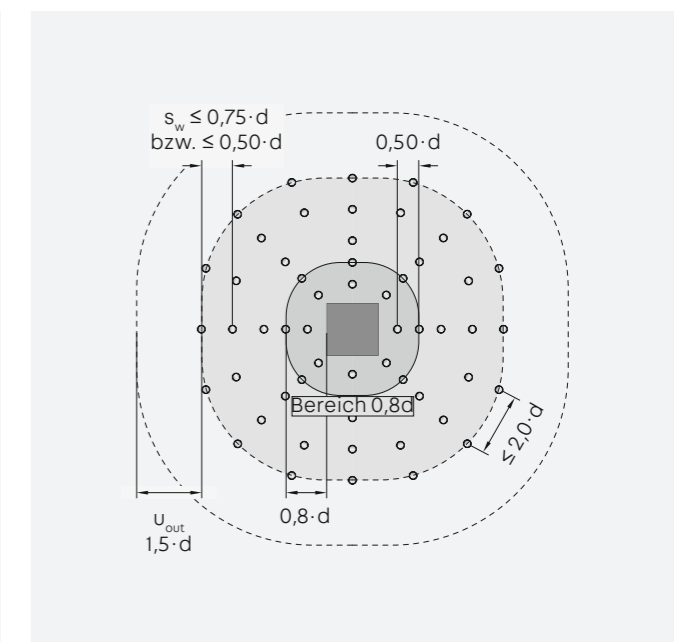

## Schematic diagram

### Separate standard elements in ceiling slabs

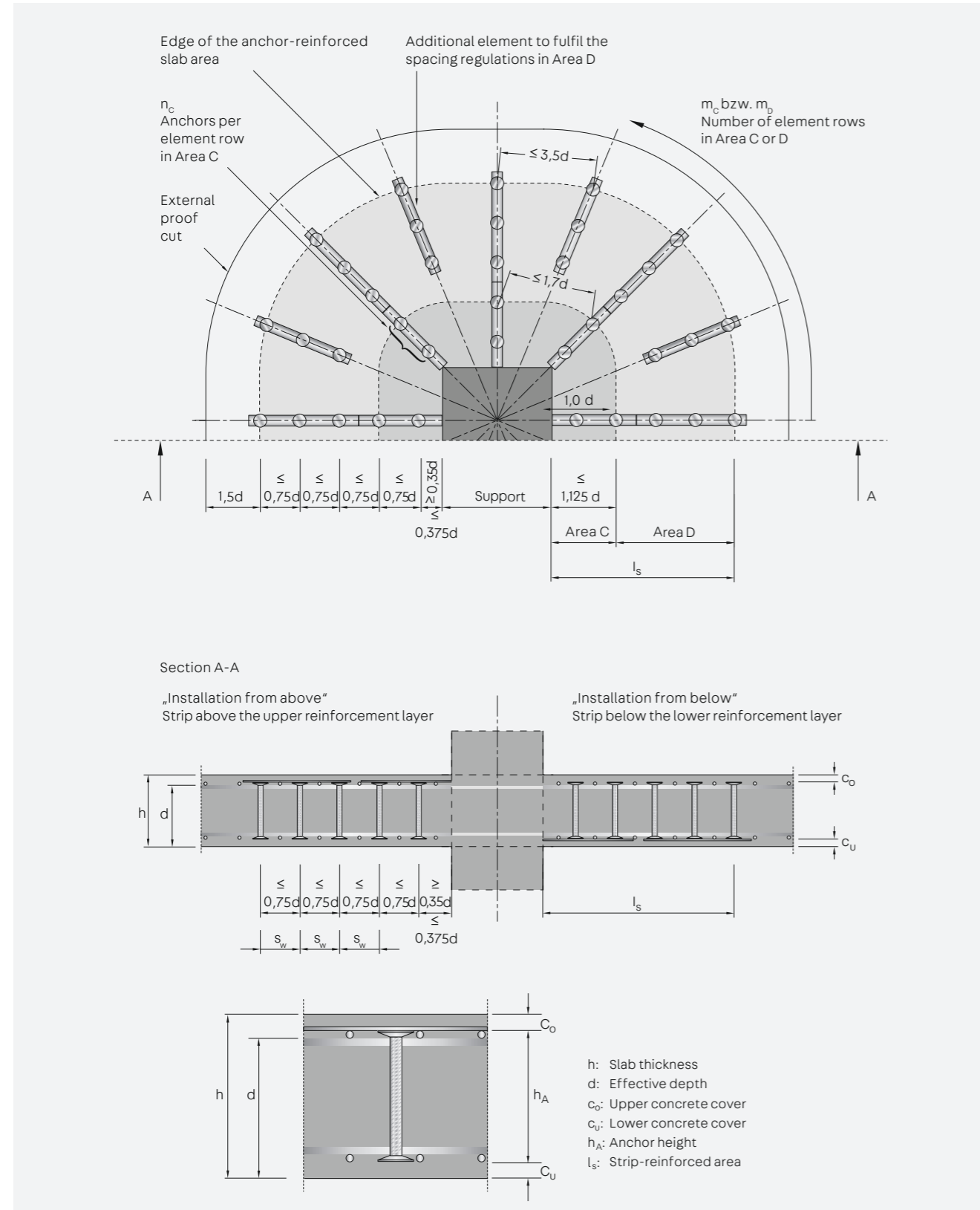

### Continuous elements in ceiling slabs

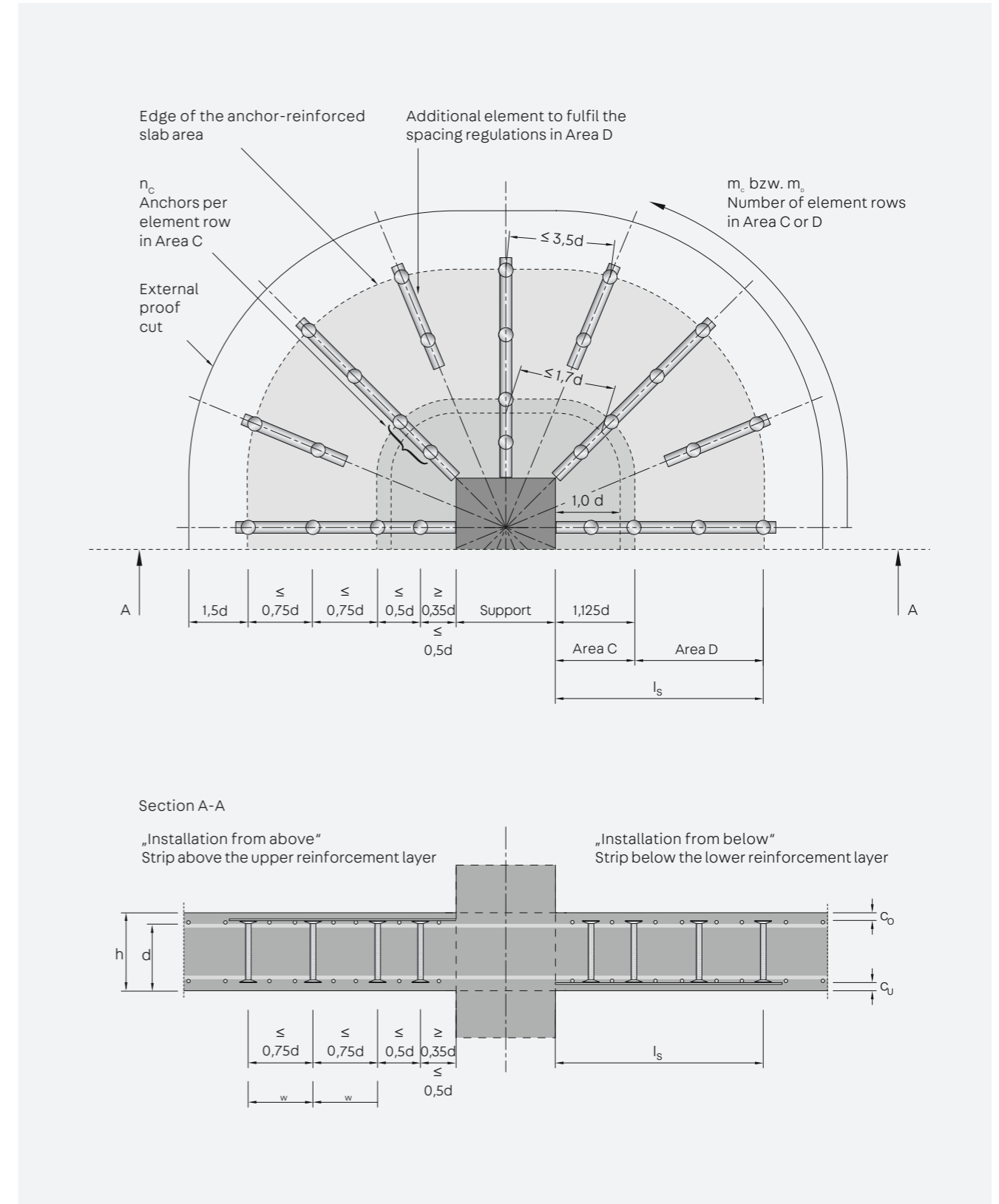



## Continuous elements in footings and floor slabs

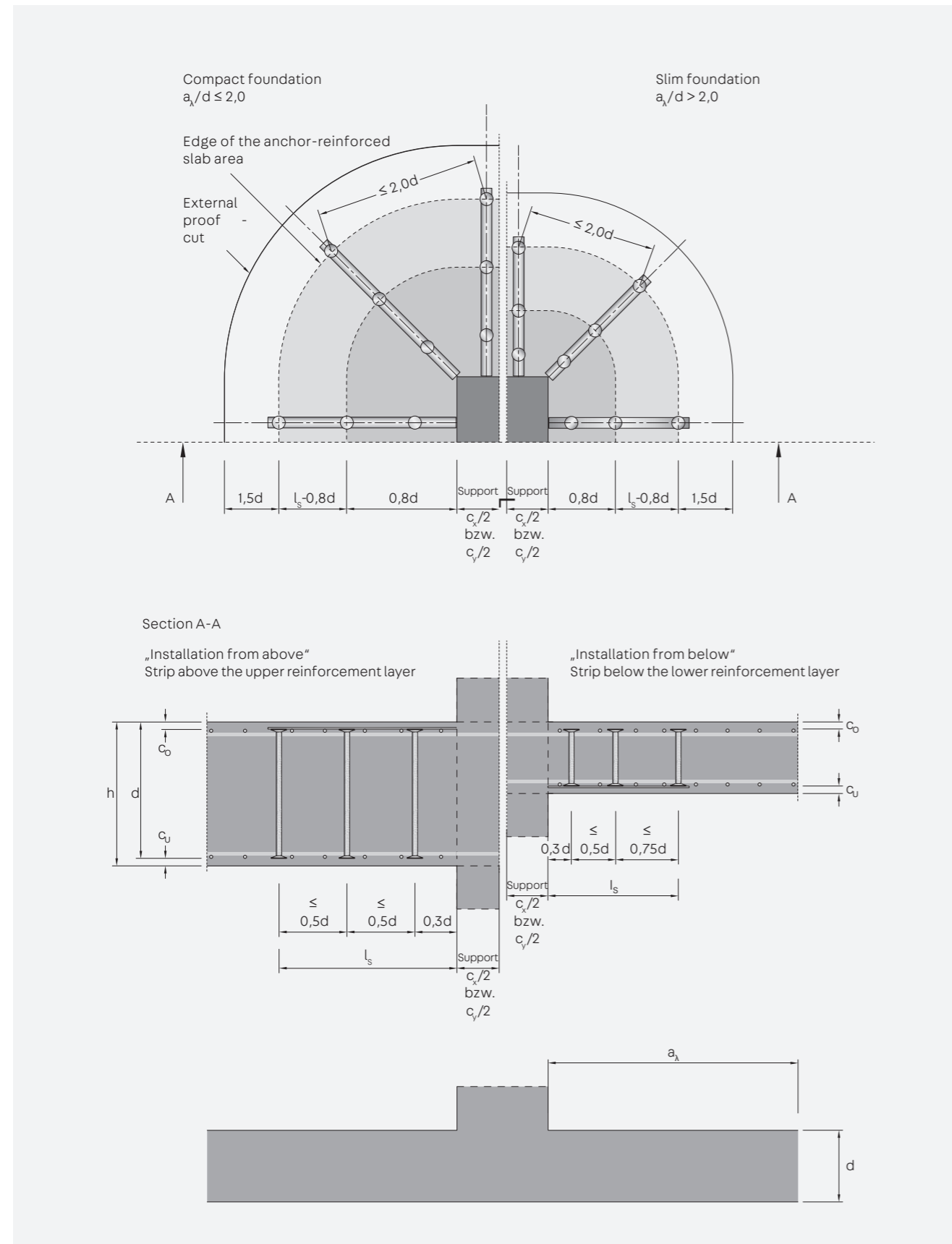

## Sample calculation

### 1. Given values:

Slab depth  $h = 350$  mm  
Effective static depth  $d = 305$  mm  
Concrete C35/45  
Reinforcement ratio  $\rho = 1.0\%$   
Punching shear load  $V_{Ed} = 800$  kN

### Round cut-out perpendicular to the edge:

$$u_1 = 2 \cdot 300 + 400 + 2 \cdot 200 + 2.0 \cdot \pi \cdot 305 = 3316 \text{ mm} < 5233 \text{ mm}$$

### Full round cut-out:

$$u_1 = 2 \cdot 300 + 2 \cdot 400 + 2 \cdot 2.0 \cdot \pi \cdot 305 = 5233 \text{ mm}$$

### 2. Punching shear verifications

#### 2.1 Minimum resistance

$$V_{min} = 1/1.50 \cdot \sqrt{(1.81^3 \cdot 35.00 \text{ N/mm}^2)} \cdot 0.0525 = 0.50 \text{ N/mm}^2$$

#### 2.2 Critical round cut-out

$$V_{Ed} = 1.40 \cdot 800.00 \text{ kN} / (3316 \text{ mm} \cdot 305 \text{ mm}) = 1.11 \text{ N/mm}^2$$

$$V_{Rd,c} = \max [0.12 \cdot 1.81 \cdot (100 \cdot 0.0100 \cdot 35.00 \text{ N/mm}^2)^{1/4}; 0.50 \text{ N/mm}^2] = 0.71 \text{ N/mm}^2$$

$$V_{Rd,max} = 1.96 \cdot 0.71 \text{ N/mm}^2 = 1.39 \text{ N/mm}^2$$

$$V_{Ed}/V_{Rd,c} = 1.56 > 1 \quad \rightarrow \text{JDA required}$$

$$V_{Ed}/V_{Rd,max} = 0.80 \leq 1 \quad \rightarrow \text{OK}$$

#### 2.3 Area C

$$\beta \cdot V_{Ed} = 1120.00 \text{ kN}$$

$$V_{Rd,sy} = 4 \cdot 2 \cdot 490.87 \text{ mm}^2 \cdot 434.78 \text{ N/mm}^2 / 1.11 = 1545.15 \text{ kN}$$

$$\beta \cdot V_{Ed} / V_{Rd,sy} = 0.72 \leq 1 \quad \rightarrow \text{OK}$$

#### 2.4 External round cut-out

$$l_s = 770 \text{ mm}$$

$$V_{Ed} = 1.10 \cdot 800.00 \text{ kN} / (5256 \text{ mm} \cdot 305 \text{ mm}) = 0.55 \text{ N/mm}^2$$

$$V_{Rd,ca} = \max [0.10 \cdot 1.81 \cdot (100 \cdot 0.0100 \cdot 35.00 \text{ N/mm}^2)^{1/4}; 0.50 \text{ N/mm}^2] = 0.59 \text{ N/mm}^2$$

$$V_{Ed}/V_{Rd,ca} = 0.93 \leq 1 \quad \rightarrow \text{OK}$$

### 3. Selected strip elements

8 x JDA-2/25/295-440 (110/220/110)



#### Note:

Structural designs can be generated using the software JORDAHL® EXPERT JDA punching shear reinforcement.

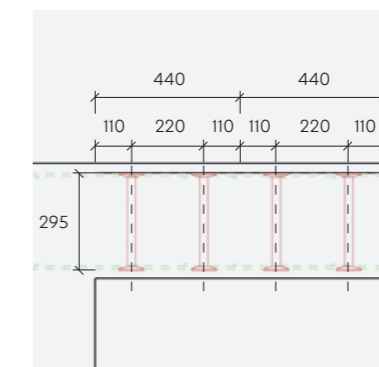
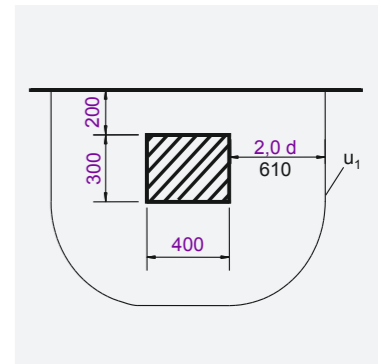

Cross section (from JORDAHL® EXPERT software)

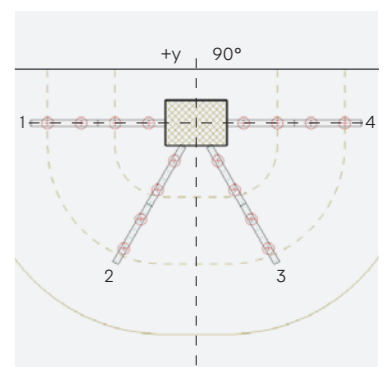

Top view (from JORDAHL® EXPERT software)

# JORDAHL® EXPERT JDA punching shear reinforcement

The program is based on the European Technical Assessment ETA-13/0136, which is regulated by Eurocode 2 (EN 1992-1-1).



## Benefits

- Most cost-effective solution is displayed first
- Quick and clear input of load specifications
- Easy project input and configuration
- Print out verifiable structural calculations
- Design earthquake load and fatigue load cases
- 3D view of columns
- Interactive edge insertion
- Effect of entered data is immediately shown and understandable
- For static calculation of cast-in-place concrete slabs, foundation slabs, precast slabs and footings

## Settings

Options/Settings can be used to define how the design result is determined:

- Separate standard elements
- Optimised continuous elements
- Optimised separate elements
- Continuous standard elements

## Column type

- Interior, edge and corner columns
- Wall ends and inner corners

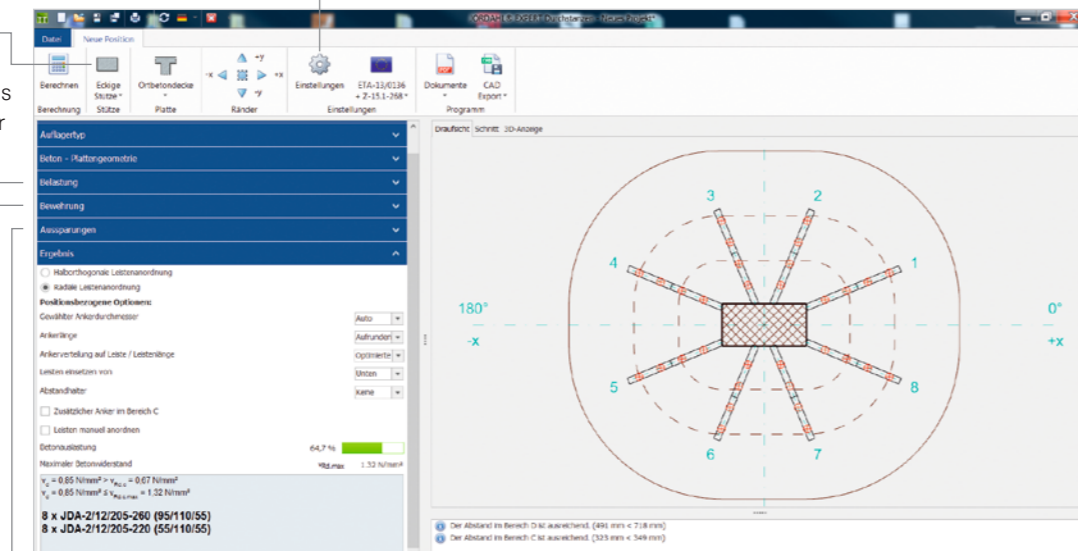

## Load → Load increase

There are three selection options for the load increase factor  $\beta$ :

- Constant factor in line with ETA-13/0136
- Fully plastic shear stress distribution
- User-defined input



## Load → Earthquake

Calculates the minimum shear force reinforcement level according to DIN 4149 and provides detailed and comprehensible verification.

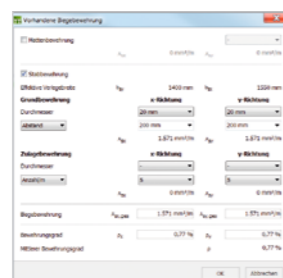

## Reinforcement ratio

Reinforcement ratios in x and y directions are entered separately to determine the average reinforcement ratio  $\rho$

- Reinforcement bars
- Mesh reinforcement with database of the most common mesh types

## Cut-outs

- Automatic inspection of the effects of cut-outs
- Cut-outs can be inserted and moved with a click of the mouse
- The program automatically recognises overlapping cut-outs
- Manual input of round cut-out deduction lengths
- Correct dimensions directly in the drawing
- Cut-out positions are listed in the final printout

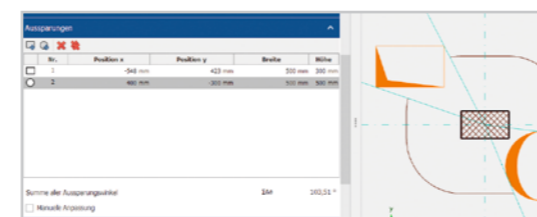

## Results

The punching shear area is displayed in plan and section views and immediately gives you an overview of how the JDA elements are arranged.



## Benefits:

- Verifiable printout of results
- Easily understandable intermediate results, final results and verifications (punching shear, earthquake load and composite material verification)
- Resulting graphics can be transferred as \*.DXF or \*.DWG files.

## Print results

Comprehensive and clear printout containing all test-relevant information.

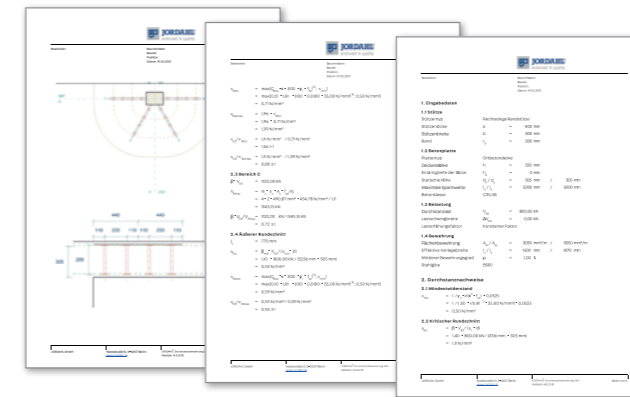

## Arrange manually

JDA elements can be moved manually with the click of a mouse.

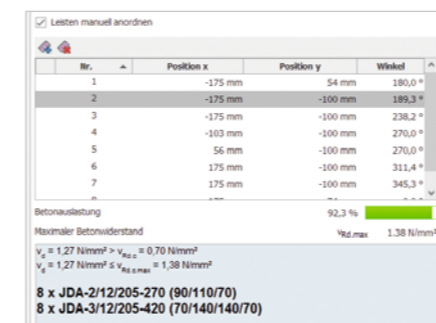

## Views

Cross section

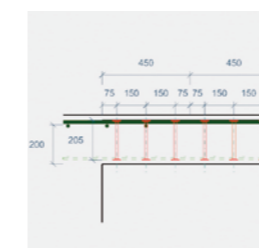

3D



## Parts list / tender text

All calculated items can be added to the parts list, which can also be called up as an order list. Tender texts are also generated automatically.

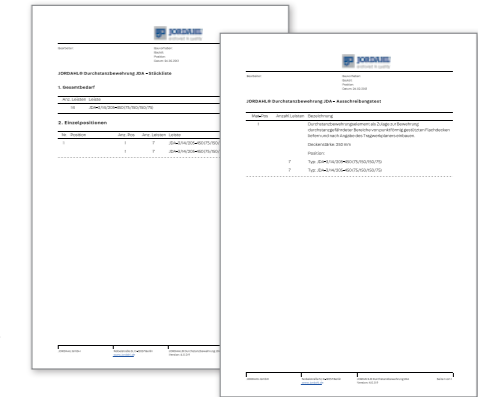

## Composite material verification

This function is used to calculate the load capacity of lattice girders and shear lattice girders. Composite material verifications are performed economically and factor in the double-headed anchors and lattice girders (in line with Eurocode 2). The results are then printed in a clear and comprehensible manner.

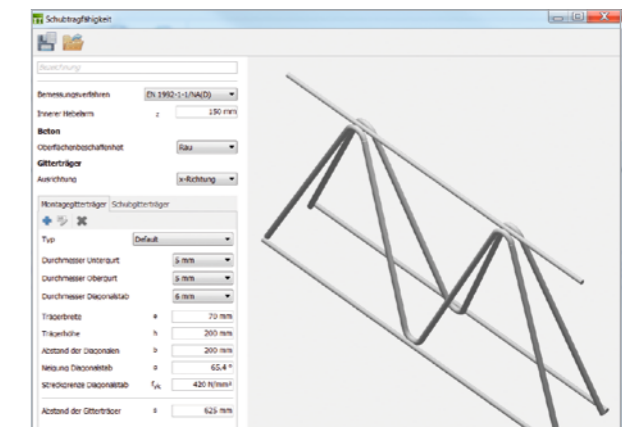

## Determine punching shear loads

The punching shear load can be estimated using the load application areas.

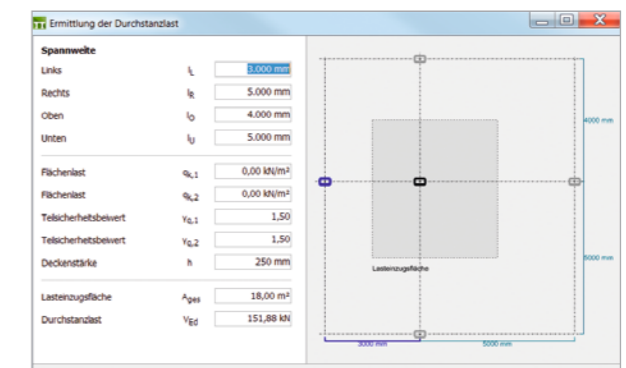

# Installation

## Arrangement on site

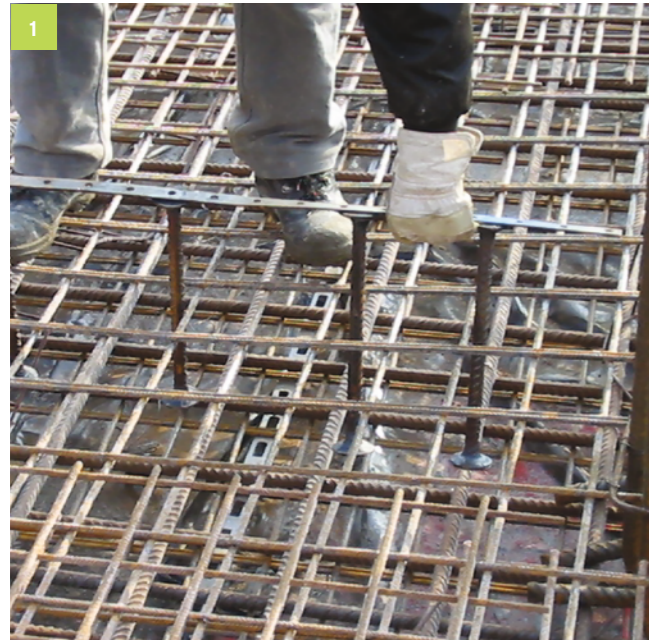

### Positioning the JDA reinforcement elements

For cast-in-place concrete slabs, it is advisable to install the JDA elements from above. They can be positioned after laying all the flexural reinforcement.

### Aligning the projecting ends of the strips with the edge of the column

This enables the position of the JDA elements to be checked and any necessary corrections made.



### Reliable height positioning

Double-headed anchors extend between the reinforcement layers.

### Pouring the slab

The slab can be poured after aligning the JDA elements.

# Installation in cast-in-place concrete

JDA elements can be used in cast-in-place concrete with the strips facing up or down. In either case, the heads of the

JDA anchors must extend between both layers of flexural reinforcement.

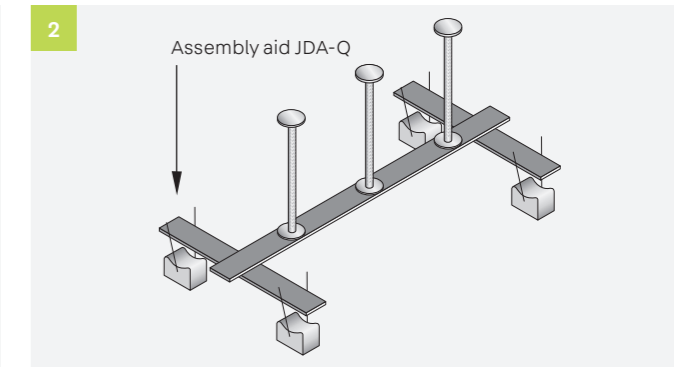
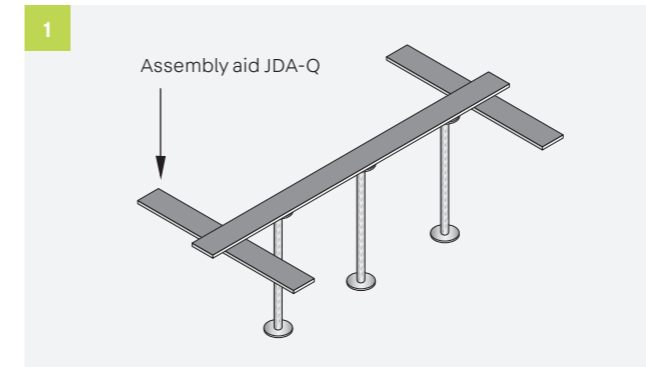

### Pre-assembly with JDA-Q assembly aids

**1) Installation from above:** If the JDA reinforcement elements are arranged parallel to the upper reinforcement layer, use JDA-Q assembly aids and fastened them e.g. with tie wire.

**2) Installation from below:** JDA-Q assembly aids can also be

used in this case to improve the stability of the elements. AH-DA spacers must be used to ensure that the required concrete cover thickness is maintained.

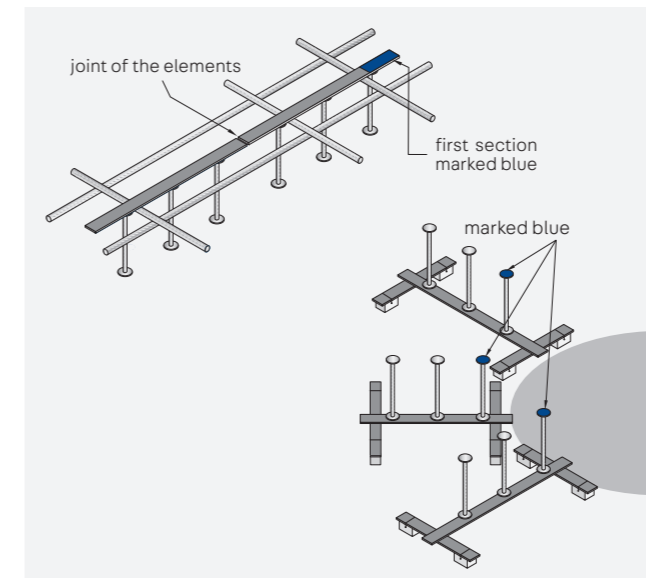

Anchors arranged in the punching shear area of a column must all have the same diameter.

**AH-DA spacers**  
Suitable AH-DA spacers must be used to mount JDA elements on the formwork. JORDAHL carries spacers for concrete coverings 20, 25, 30 and 35 mm thick.

### Arrangement

Position the reinforcement elements according to the plan. If asymmetrical elements are used, the section marked in blue must face towards the column.



### Note:

Before installation, compare the anchor diameters, anchor spacing and anchor height with the information in the formwork and reinforcement plans. The lower anchor heads must reach at least to the lower edge of the lowest reinforcement layer and the upper anchor heads at least to the upper reinforcement layer.

## Installation in precast slabs

The JDA-FT Klick system was developed specifically for precast slabs. The JDA elements are delivered unassembled, i.e. as a kit consisting of anchors + mounting strips + spacers. This prevents any obstruction of the automatic production

process and avoids collisions between the flexural reinforcement, lattice girders and JDA elements. On the construction site, the upper reinforcement layer can simply be laid without any additional effort and without being impeded by mounting strips.

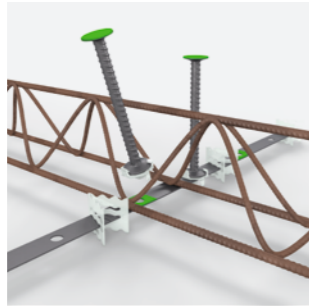

Strip

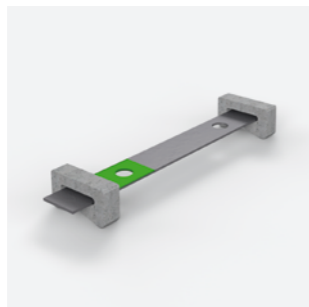

Fastening the strips to the formwork using spacers



Double anchors are clicked into place



### FBA spacers

Suitable spacers must be used to install JDA elements in precast structures. JORDAHL carries fibre reinforced concrete spacers for concrete coverings 15, 20, 25 and 30 mm thick.

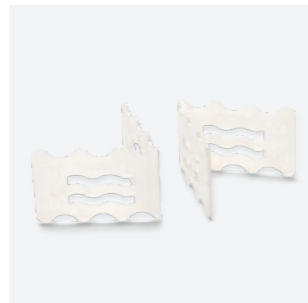

### AH-FT spacers

Alternatively, AH-FT plastic spacers are available for installing JDA elements in precast structures. These spacers can be used variably for concrete coverings of four different thicknesses (c = 15, 20, 25 and 30 mm). They offer optimum flexibility and take up minimal storage space.

## Installation



Mounting strips are positioned and fixed according to the planning specifications. These accommodate the double-headed anchors later on.

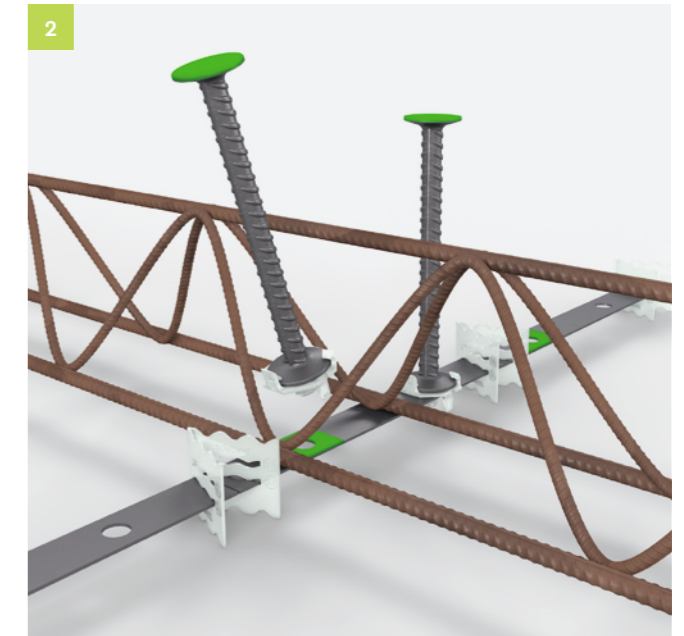

Lattice girders and lower flexural reinforcement are automatically positioned.



JDA double-headed anchors are clicked into pre-punched holes in the mounting strips using patented plastic connectors.



### Installation benefits

- All element components provided as a kit
- Parts clearly colour-coded
- Easy click-in assembly even for greater distances
- Anchor spacing always corresponds exactly to the quality specifications
- No impermissible deviations in anchor spacing
- Universal spacers
- After pouring the concrete, the slab element is ready for transport without needing any further finishing work
- Perfect for storage
- Technical training provided by JORDAHL® employees and quality agreement

# Our synergy concept for you

With us, you benefit from the collective experience of three established manufacturers who combine their products and expertise to form a truly comprehensive range. This is the PohlCon synergy concept.



#### Full-service consulting

Our extensive network of advisors is available to answer all your questions about our products on site. You will enjoy personal support from our qualified staff right from the planning stage through to construction.



#### Digital solutions

Our digital services give you targeted planning assistance when using our products. We provide tailor-made planning support from tender specifications to CAD details, BIM data and modern software solutions.



#### Seven fields of application

We think in terms of holistic solutions. That is why we have grouped our products into seven fields of application in which you can benefit from the synergy of the PohlCon product range.

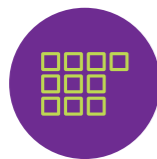

#### Ten product categories

The products are divided into ten product categories to help you find the right product from our extensive range even faster. This allows you to navigate unerringly through our products.



#### Custom solutions

Can't find a series product on the market that is suitable for your project? We master extraordinary challenges by harnessing the many years of expertise in the field of custom solutions of our three manufacturer brands. In this way, we can build unique construction projects together.



Errors and technical changes reserved. Reprinting and any electronic reproduction only authorised with our written permission. All previous documents lose their validity with the publication of this printed matter.

**PohlCon Vertriebs GmbH**

Nobelstrasse 51  
12057 Berlin, Germany

T +49 30 68 283 - 04  
F +49 30 68 283 - 383

[www.pohlcon.com](http://www.pohlcon.com)