



**Technický a zkušební ústav
stavební Praha, s.p.**
Prosecká 811/76a
190 00 Prague
Czech Republic
T: +420 286 019 400
W: www.tzus.cz



European Technical Assessment

ETA 21/1071
of 02/12/2023

General Part

Technical Assessment Body issuing the European Technical Assessment
Technický a zkušební ústav stavební Praha, s.p.

Trade name of the construction product	Liftschachtanker JLF	
Product family to which the construction product belongs	Product area code: 33 Fixings	
Manufacturer	PohlCon GmbH Nobelstraße 51 12057 Berlin Germany	
Manufacturing plants	PohlCon GmbH Nobelstraße 51 12057 Berlin Germany PohlCon GmbH Industriestraße 5 14959 Trebbin Germany PohlCon GmbH Am Güterbahnhof 20 79771 Klettgau Germany PohlCon GmbH Industriestraße 1 54614 Schönecken Germany PohlCon AG Wasterkingergeweg 2 8193 Eglisau Switzerland	
This European Technical Assessment contains	13 pages including 6 Annexes, which form an integral part of this European Technical Assessment	
This European Technical Assessment is issued in accordance with Regulation (EU) No 305/2011, on the basis of	EAD 330075-01-0601 Elevator Lifting Device	
This version replaces	ETA 21/1071, version 01 issued on 14/05/2023	

Translations of this European Technical Assessment in other languages shall fully correspond to the original issued document and should be identified as such.

Communication of this European Technical Assessment, including transmission by electronic means, shall be in full (excepted the confidential Annex(es) referred to above). However, partial reproduction may be made, with the written consent of the issuing Technical Assessment Body. Any partial reproduction has to be identified as such.

1 Technical description of the product

The Lift Shaft Anchor (Liftschachtanker JLF from JORDAHL) is a pre-installed lifting device for the attachment of loads during installation and maintenance work. It consists of a steel loop, steel bolt, plastic cover and a shackle (anchor) located in plastic housing. The shackle is released out of housing by small tension or loading the anchor. The Liftschachtanker JLF is fully embedded in concrete and anchored by bonding and mechanical interlock. It can be used for precast and cast-in-situ slabs.

The product description is given in Annex A.

2 Specification of the intended use(s) in accordance with the applicable European Assessment Document (hereinafter EAD)

The product is intended to be cast into the ceiling of an elevator shaft, to transfer the load from the elevator car to the concrete slab during the elevator installation. It can be used for precast and cast-in-situ slabs. Typically, three elevator lifting devices are embedded in each slab. The elevator lifting device is placed into a slab made of compacted reinforced normal weight concrete, strength classes in the range C25/30 to C50/60 all in accordance with EN 206. After setting of the concrete and removing of the plastic cover, a steel rope or similar can be attached. The unfolding the shackle can be done automatically by pushing onto the opening mechanism, so that the working condition is established and the shackle is unfolded vertical to the ceiling. The lifting device is designed to carry static or quasi-static tensile loads only.

The provisions made in this European Technical Assessment are based on an assumed working life of 50 years. The real working life may be considerably longer without major degradation affecting the basic requirements, provided that the Liftschachtanker JLF are subject to appropriate use and maintenance.

The indications given as to the working life cannot be interpreted as a guarantee given by the producer or Technical Assessment Body but are regarded only as a mean for choosing the right products in relation to the expected economically reasonable working life of the works.

3 Performance of the product and references to the methods used for its assessment

The assessment of the fitness for use of the Liftschachtanker JLF according to the basic work requirements (BWR) were carried out in compliance with EAD 330075-01-0601.

The European Technical Assessment is issued for the Liftschachtanker JLF on the basis of agreed data and information, deposited at Technický a zkušební ústav stavební Praha, s.p., which identifies the Liftschachtanker JLF that has been assessed and judged. Changes to the Liftschachtanker JLF or production process which could result in this deposited data and information being incorrect should be notified to Technický a zkušební ústav stavební Praha, s.p. before the changes are introduced. Technický a zkušební ústav stavební Praha, s.p. will decide whether or not such changes affect the ETA and consequently the validity of the CE marking on the basis of the ETA and if so whether further assessment or alternations to the ETA shall be necessary.

Table 1 Essential characteristics of the product

Essential characteristic	Performance
BWR 2: Safety in case of fire	
Reaction to fire	Cl. 3.1
BWR 4: Safety and accessibility in use	
Load bearing capacity	Cl. 3.2
Minimum edge distances and spacing	Cl. 3.2

3.1 Safety in case of fire

3.2.1 Reaction to fire

Reaction to fire classification is A1.

3.2 Safety and accessibility in use

3.2.1 Load bearing capacity

See Annex B.

3.2.2 Minimum edge distances and spacing

See Annex B.

4 Assessment and verification of constancy of performance (hereinafter AVCP) system applied, with reference to its legal base

According to the decision 97/161/EC¹, of the European Commission the system(s) of assessment and verification of constancy of performance (see Annex V to Regulation (EU) No 305/2011) given in the following table applies:

Product(s)	Intended use(s)	Level(s) or class(es)	Attestation of conformity system(s)
Metal anchors for use in concrete (light-duty type)	For use in redundant systems for fixing and/or supporting to concrete elements such as lightweight suspended ceilings, as well as installation		2+

¹ 97/161/EC – Commission Decision of 17 February 1997, published in the Official Journal of the European Communities, L 62/41 of 04/03/1997
ETA 21/1071 - version 02 - of 02/12/2023
070-063788

5 Technical details necessary for the implementation of the AVCP system, as provided for in the applicable EAD

Technical details necessary for the implementation of the AVCP system are laid down in the control plan deposited at the Technický a zkušební ústav stavební Praha, s.p.

Issued in Prague on 02/12/2023

By

Ing. Jiří Studnička, Ph.D.
Head of the TAB

Annexes:

Annex A Product description	2 pages
Annex B Installation parameters	1 page
Annex C Specification of the intended use	1 page
Annex D Assembly instructions of the product	1 page
Annex E Performance and tolerance	1 page
Annex F Reference documents	1 page

The geometries and materials of the elevator lifting device are specified by the drawings provided separately. The elevator lifting device is placed into a concrete slab made of normal weight concrete with a minimum strength class C25/30 in accordance with EN 206. The steel bolts M12 and M16 are made of galvanized grade respectively 8.8 and 10.9 carbon steel in accordance with EN ISO 898-1. The steel loops are made of stainless steel $f_u = 850$ MPa, the shackle of galvanized carbon steel $f_u = 980$ MPa. The geometry is shown in Figure A.1.

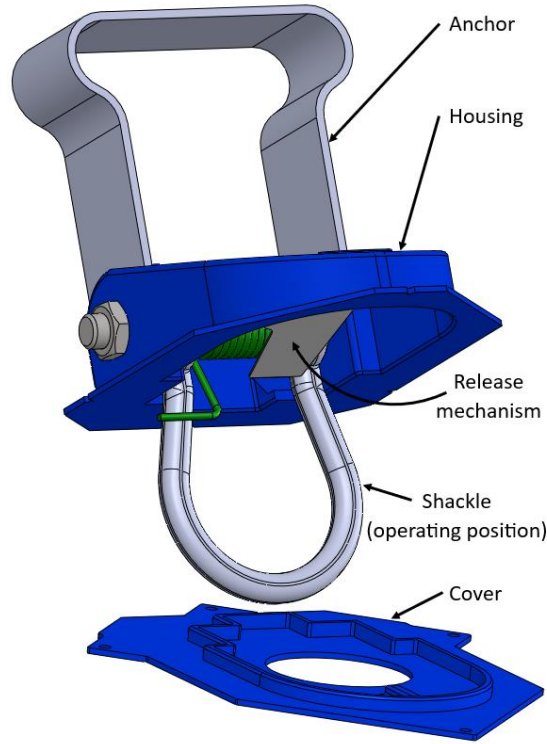

Figure A.1: Scope of delivery and part description

The dimensions of the elevator lifting device are given in Table A.2. The two types of elevator lifting devices are characterized by the nominal depth h_{nom} and thickness t of the steel loop (see Figure A.2). Housing and cover differs in colour for each type of the JLF (table A.1).

Table A.1: Product identification

	Type of Elevator lifting device	
	JLF 20	JLF 40
Colour of housing and cover	blue	red

Liftschachtanker JLF

Product description

Annex A

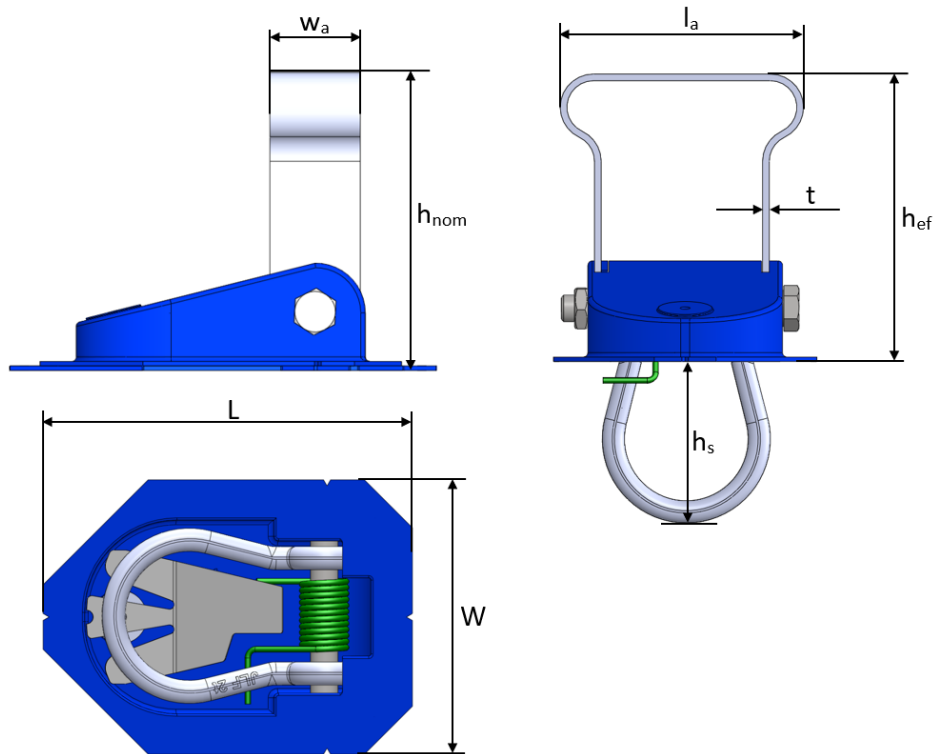

Figure A.2: Dimensions of elevator lifting device

Table A.2: Geometry of elevator lifting device

			Type of Elevator lifting device	
			JLF 20	JLF 40
Effective embedment depth	h_{ef}	[mm]	127	197
Nominal embedment depth	h_{nom}	[mm]	130	200
Length	L	[mm]	160	160
Width	W	[mm]	119	119
Thickness steel loop anchor	t	[mm]	3	5
Length steel loop anchor	l_a	[mm]	110	119
Width steel loop anchor	w_a	[mm]	40	40

Liftschachtanker JLF

Product description

Annex A

The embedment depth h_{ef} , concrete height h_{min} , edge distance c_{min} , and spacing s_{min} determine the capacity of the elevator lifting device (see Figure B.1).

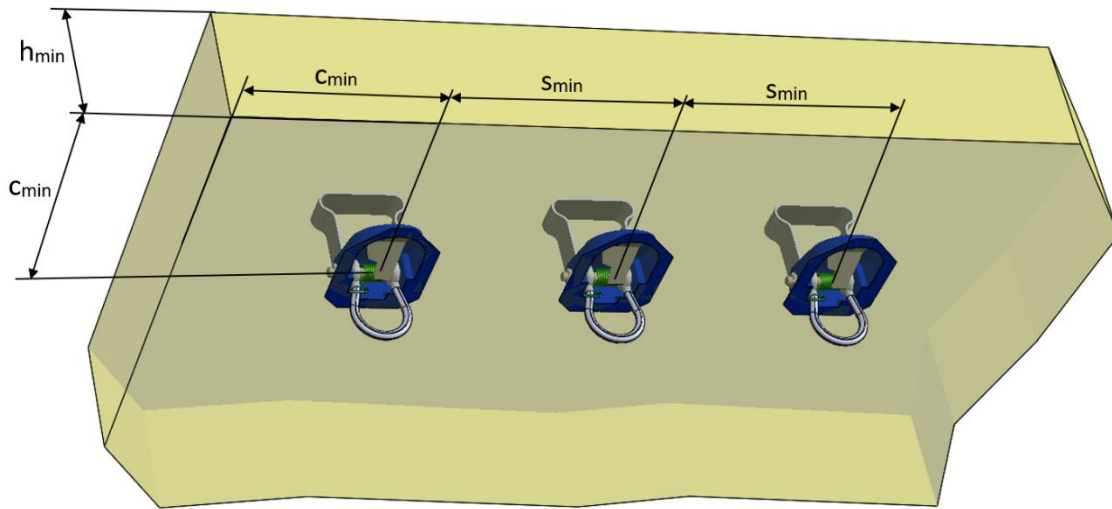

Figure B.1: Installation parameters

Table B.1: Minimum edge distances and spacing

			Type of Elevator lifting device	
			JLF 20	JLF 40
Minimum component height	h_{min}	[mm]	130 ¹	200 ¹
Minimum edge distance	c_{min}	[mm]	250	350
Minimum spacing	s_{min}	[mm]	500	700

¹ Sufficient corrosion protection to the anchor must be ensured by a corresponding concrete covering

The concrete slab is reinforced at the top and the bottom with B500A reinforcement bars, $\varnothing = 10$ mm every 150 mm, equivalent to a relative reinforcement area of 628.31 mm²/m and 942.48 mm²/m respectively for JLF 20 and JLF 40.

Liftschachtanker JLF	Annex B
Installation parameters	

Base materials

- Reinforced and unreinforced normal concrete without fibres according to EN 206
- Strength class C 25/30 to C 50/60 according to EN 206
- Cracked or uncracked concrete

Use conditions

- Anchorages subject to dry internal conditions
- Static and quasi-static loads
- Transverse and oblique tensile loading outside the tolerance (see Annex E) are not permissible

Design

- Anchorages are designed under the responsibility of an engineer experienced in the field of anchorages and concrete works
- Verifiable calculations and design drawings must be prepared taking into account the loads to be anchored

Installation

- Anchor installation carried out by appropriately qualified personnel and under the supervision of the technical site manager
- Use of the box only as supplied by the manufacturer, without alternations or replacement of components
- The box is fixed to the formwork in such a way that it cannot move when the reinforcement is laid or when the concrete is placed and compacted
- Adequate compaction of the concrete around the anchor and especially around the head of the anchor, e.g., without significant voids

Liftschachtanker JLF**Specification of the intended use****Annex C**

		<p style="text-align: center;">Scope of delivery</p> <p>Casing and cover made of plastic (20 kN load in blue and 40 kN load in red) Shackle (folded in and secured on delivery) and anchor made out of steel. Both are connected by a special screw. A spring inside the storage box fitted with loaded opening mechanism for establishing working condition. Label in and outside of the casing.</p>
<div style="display: flex; flex-direction: column; align-items: center;"> <div style="display: flex; justify-content: space-around; width: 100%;"> <div data-bbox="140 539 451 763"> </div> <div data-bbox="472 539 675 763"> </div> </div> <div data-bbox="156 779 435 1010"> </div> <div data-bbox="156 1025 427 1249"> </div> <div data-bbox="165 1265 368 1480"> </div> <div data-bbox="169 1496 368 1742"> </div> </div>		<p style="text-align: center;">Installation</p> <ol style="list-style-type: none"> 1.) Fasten the casing by using nails to the formwork at the previously marked position according to the formwork plan. Alternatively, the casing can be glued to the formwork. 2.) Pour in the concrete for the lift shaft ceiling and be aware that the vibrator will not have any contact with the Lift Shaft Anchor. 3.) After the concrete is hardened, remove the formwork. The cover and nails will be removed simultaneously in this process step. 4.) Unfold the shackle by pushing onto the opening mechanism, e.g. with a metal pole. 5.) The working condition is established. The shackle is unfolded vertical to the ceiling.
<p>Liftschachtanker JLF</p>		<p>Annex D</p>
<p>Assembly instructions of the product</p>		

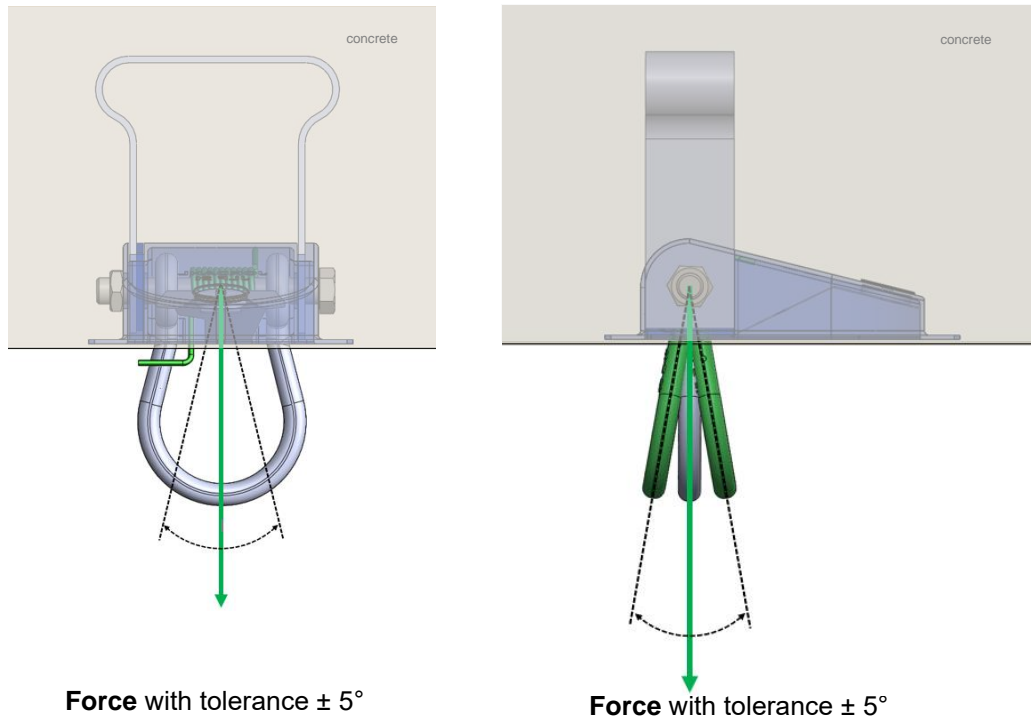

Figure E1: Planned load direction ¹

Table E1: Characteristic resistances under tension loading in concrete C25/30 to C50/60

	Type of Elevator lifting device			
	JLF 20-13	JLF 20-15	JLF 40-20	JLF 40-22
Steel and concrete failure				
Minimum component height h_{min} [mm]	130	150	200	220
Characteristic resistances in concrete C25/30 to C50/60 ¹ F_{Rk} [kN]	94.2	100.7	190.6	181.3
Splitting failure				
Reinforcement has to be present to resist the splitting forces and limit the crack width $w_k \leq 0.3$ mm.				
¹ The resistances apply taking into account a tolerance of the load direction angle of +5° in each direction with regard to the vertical.				
Liftschachtanker JLF	Annex E			
Performance and tolerance				

- [1] European Assessment Document EAD 330075-01-0601 Elevator Lifting Device (edition October 2018)
- [2] EN 206+A2 Concrete - Specification, performance, production and conformity
- [3] EN 1990 Eurocode: Basis of structural design

Liftschachtanker JLF

Reference documents

Annex F