

JORDAHL[®] channels and accessories

Technical information



Table of contents

JORDAHL® channels and bolts	4	Planning notes	24	Mounting channels JM, JXM and JZM	40
Applications and fields of use	4	Ranges JTA-CE, JXA and JZA	24	Profile overview: Hot-rolled mounting channels	42
Approvals and certificates	8	Fire load	25	Rated resistances for JM W and JXM W	43
Benefits and features	9	Dynamic loads	26	Profile overview: Cold-formed mounting channels	44
Materials and marking	10	Installation	28	Technical data	46
Corrosion protection in the atmosphere	11				
		Anchor channels – Custom solutions	30	Bolts	48
Anchor channels JTA	12	Anchor channel pairs	32	Determining the bolt length	49
Profile overview JTA W-CE	14	Curved anchor channels	32	Hook-head t-bolt range	50
Profile overview JTA K-CE	15	Railing fastening channels JGB	34	Tee-head bolt range	51
JORDAHL® EXPERT software	16	Facade fastening channels JTA-RF and JTA-RT	36	Rated values for steel bolts	52
		Anchor channel corner pieces	38	Rated values for stainless steel bolts	53
Toothed anchor channels JXA, JZA and JXA-PC	18	Anchor channels JSA	39	Toothed and double-notch toothed t-bolts range	54
Profile overview JXA W-CE and JZA K-CE	20			Pretensioned bolt connection	56
Profile overview JXA-PC W	21			Loads on bolts in longitudinal direction of channel	58
Technical data for JXA-PC W	22				

Accessories	59	Index and service	81
<hr/>		<hr/>	
Bolt accessories	60	Index	81
<hr/>		<hr/>	
JORDAHL® connection straps JVB	62	Service	82
<hr/>			
Other accessories	64		
JORDAHL® profiled metal sheet channels JTB	69		
<hr/>			
Applications and fields of use	70		
<hr/>			
Technical data	71		
<hr/>			
Installation and assembly	72		
JORDAHL® products for wall connection	74		
<hr/>			
Brick tie anchor JMA and nail anchor JNA	74		
<hr/>			
Brick tie channels	75		
JORDAHL® Scaffold shoes JG	76		
<hr/>			
JORDAHL® Edge protection angles JKW	77		
<hr/>			
JORDAHL® Profile brackets JKO	78		

JORDAHL® channels and bolts

Applications and fields of use

JORDAHL® anchor channels, together with the matching JORDAHL® bolts, offer an excellent fastening system. They are embedded in concrete and reliably transfer high loads into reinforced and unreinforced concrete components. Thanks to their flexibility, JORDAHL® anchor channels and bolts with European Technical Assessment (ETA) certification can be

used in a wide range of applications. With their numerous advantages for installation and assembly as well as their first-rate safety and quality, they are popular with planners and users all over the world. In countless projects, they have proven themselves internationally and set new standards in fastening technology.

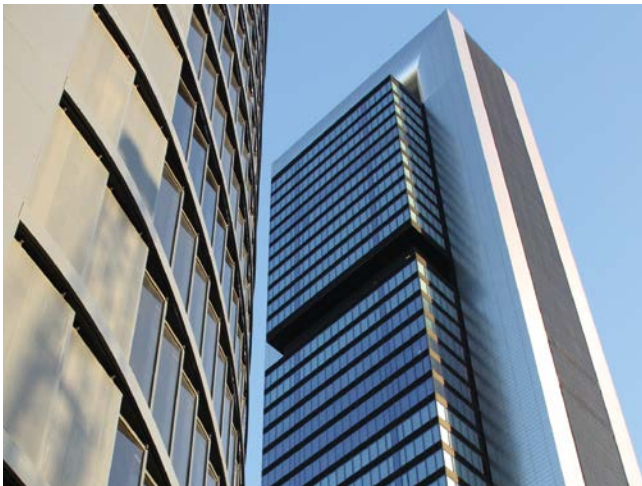

Torre PwC and Torre Cepsa, Madrid, Spain

Lift construction

JORDAHL® anchor channels and bolts are ideally suited for the safe and reliable fastening of elevator guide channels. This is the case in Torre PwC (formerly Torre Sacyr Vallehermoso), Spain's third tallest building at 236 m.



Canary Wharf, London, United Kingdom

Curtain-wall facing

JORDAHL® anchor channels and bolts satisfy the requirements for modern building technology. Numerous glass facades in London's new Canary Wharf business district were installed using reliable and flexible PohlCon products.



Tunnel construction

JORDAHL® anchor channels, manufactured as paired channels, are particularly advantageous for the long-term and secure fastening of contact wires or overhead lines, signal systems, lighting and ventilation systems in tunnels – such as here in the City Tunnel in Leipzig.



City Tunnel, Leipzig, Germany

Stadium construction

JORDAHL® anchor channels and bolts are used in stadium construction because they can be firmly anchored in concrete and offer a simple, flexible and secure fastening option for seats, for example – such as in the ETO Park Stadium in Győr, Hungary. A major advantage is the variable adjustability of the seat spacing.



ETO Park stadium, Győr, Hungary

Prefabricated components

Small edge clearances, corrosion-free and thus particularly durable material and ETA approval are just some of the reasons why JORDAHL® anchor channels are used at JadeWeserPort, Wilhelmshaven and worldwide for linking columns and walls.

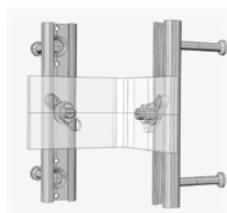

JadeWeserPort, Wilhelmshaven, Germany



Spandauer Damm Bridge in Berlin, Germany

Bridge construction

In bridge construction, the ETA-approved JORDAHL® anchor channels demonstrate their reliability, among other things, in the reliable fastening of utility lines and bracing of water pipes. This is the case with the Spandauer Damm Bridge in Berlin and numerous international projects.

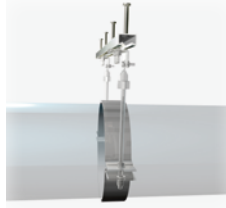

Spedition Fiege in Greven, Germany

Industrial construction

In industrial construction, JORDAHL® profiled metal sheet channels are the ideal solution for attaching trapezoidal sheet metal to reinforced concrete components without damaging the load-bearing components. In Greven, Spedition Fiege utilises these advantages.

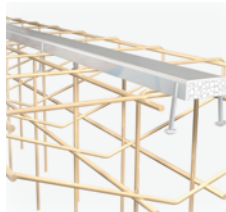

Neurath power plant in Grevenbroich, Germany

Power plant construction

The toothed JORDAHL® anchor channels JXA are approved for fatigue loads and are highly resistant to seismic loads and fire. Therefore, they are optimally suited for safety-relevant applications - such as at the Neurath power plant in Grevenbroich.



Crane rail

Hot-rolled JORDAHL® anchor channels are excellently suited for dynamic loads and resist fatigue over millions of cycles. They thus meet all requirements for the secure fastening of crane rails, such as those installed in our in-house production and storage facility in Trebbin.



PohlCon GmbH, Trebbin, located near Berlin, Germany

Civil engineering

JORDAHL® anchor channels JTA and toothed channels JXA allow for the easy compensation of construction tolerances and are highly resistant to fatigue and vibration. In the impressive Niederfinow Boat Lift, they guarantee that a wide range of machinery and equipment systems are securely anchored in concrete.



Niederfinow Boat Lift, Germany

Railing fastening

With their extra-long anchors, JORDAHL® railing fastening channels JGB offer flexible solutions for railing connections for concrete slabs with a thickness of 10 cm or more. This is the case in the MyZeil shopping centre. Featuring a curved and partly twisted glass construction, this building's architecture makes it one of the most modern-looking shopping centres in Europe.



MyZeil shopping centre, Frankfurt, Germany

Approvals and certificates

European Technical Assessment (ETA)

As a result of continuous product improvements, the German Institute for Building Technology (DIBt) has issued JORDAHL European Technical Assessment approval for the JORDAHL® anchor channels JTA-CE, JZK-CE and JXA-CE. For the ETA approval, these products undergo a technical and qualitative assessment that is based on an overarching European design concept which has unrestricted validity in over 30 countries and offers maximum planning security, even for international projects.

National technical approval (abZ)

Not all construction products currently have a basis (EAD) for obtaining a European Technical Assessment (ETA). Even so, we wish to offer our customers the assurance of JORDAHL® quality as well as a tried and tested basis for their planning: Therefore, the corresponding national technical approval confirms the safe use and applicability of PohlCon products such as the JORDAHL® profiled metal sheet channels JTB or the JORDAHL® double shear dowels JDSD. These products are labelled with a corresponding Ü mark.



TÜV Rheinland certified - ISO 9001 and ISO 50001

The TÜV seal of approval confirms that JORDAHL's production is carried out with strict quality controls in accordance with the requirements of German and European certification procedures (ISO 9001 and ISO 50001).



Approvals for North America and China

JORDAHL® anchor channels are approved by CABR for China as well as ICC for the North American market.



Environmental Product Declaration EPD

JORDAHL® anchor channels are certified by the Institut für Bauen und Umwelt e.V. (Institute for Construction and Environment) with the environmental product declaration according to ISO 14025 and EN 15804. This makes JORDAHL® channel-bolt systems suitable for building certification systems such as the DGNB certification system of the German Sustainable Building Council (Deutsche Gesellschaft für Nachhaltiges Bauen) or the Sustainable Building Assessment System for Federal Buildings (BNB) of the Federal Ministry of Transport, Building and Urban Affairs (BMVBS).



Information

Are you interested in learning more about our approvals? They are available for download at www.pohlcon.com → Downloads → Proofs of application.

Benefits and features



Planning

- Cost-effective fastening system thanks to optimised range of anchor channels categorised into load classes
- Maximum safety thanks to flexible design concept based on Eurocode (EC2)
- Optimum corrosion protection in every corrosivity category through the use of hot-dip galvanised steel or stainless steel
- Fast creation of verifiable structural analyses using the transparent, user-friendly and powerful JORDAHL® EXPERT design software
- Planned reinforcement can be included in the design
- Maximum flexibility with individual bolt spacing and positions
- Secure anchoring in concrete even with small edge clearances and delicate concrete components
- Suitable for pretensioned components
- Use in cracked zones, independent of existing reinforcement



Safety

- Suitable for cracked and non-cracked concrete, without restrictions
- No damage to concrete or reinforcement
- Resistant to fatigue and to loads due to seismic vibrations and explosions
- Optimal mechanical undercut
- Transparent safety concept (γ method)
- Approved for installation in components with fire protection requirements
- Maintenance-free for years thanks to corrosion-resistant stainless steel grades



Installation

- Construction time-reducing fastening on site
- Quick and easy installation of attachment parts
- Easy compensation of construction tolerances



Information

Do you require PohlCon assembly instructions? They are available for download at www.pohlcon.com → Downloads → Assembly instructions.

Materials and marking

The quality of the raw material is of vital importance to PohlCon so as to ensure the maximum reliability and safety of your products. To guarantee this, PohlCon only sources

material from first-rate suppliers. Quality is PohlCon's number one priority.

		Steel		Stainless steel
Profiles	S235JR = 1.0038 S275JR = 1.0044	DIN EN 10025	1.4301/1.4541-A2 ¹⁾ 1.4401/1.4404/ 1.4571-A4 ²⁾ 1.4529/1.4547 ³⁾	DIN EN 10088
Anchors	S235JR = 1.0038	DIN EN 10025 DIN EN 10263	1.4401/1.4404/1.4571- A4 ²⁾ 1.4529/1.4547 ³⁾	DIN EN 10088
Bolts	Strength class 4.6/8.8	DIN EN ISO 898-1	A4-50; A4-70 ²⁾ FA-70 ³⁾	DIN EN ISO 3506-1
Hex nuts ISO4032	Strength class 8	DIN EN 20898-2	A4-50; A4-70 ²⁾ 1.4529 ³⁾	DIN EN ISO 3506-2
Washers	Steel	DIN EN ISO 7089 (DIN 125) DIN EN ISO 7093-1 (DIN 9021)	1.4401/1.4404/ 1.4571-A4 ²⁾	DIN EN 10088

¹⁾ Corrosion resistance class II in acc.w/ Z-30.3-6 (not included in ETA).

²⁾ Corrosivity category C4 (ISO 12944-2).

³⁾ Corrosivity category C5 (ISO 12944-2).

Marking of JORDAHL® anchor channels

JORDAHL® anchor channels are permanently marked on the profile with profile type and material specifications.

JORDAHL® anchor channels JTA-CE, JZA-CE, JXA-CE, which are designed according to the European Technical Assessment (ETA), have the marking "-CE".

JORDAHL® anchor channels with round anchors are additionally stamped with the profile designation on the rivet head in the inner channel chamber.

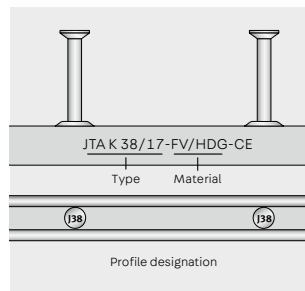

Marking of JORDAHL® bolts

JORDAHL® bolts are stamped with the type and strength class on the bolt head.

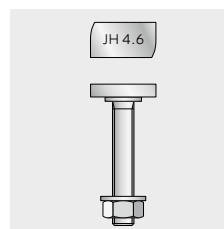

Information

Would you like to know more? The declarations of performance (DOP) and the certificates of conformity are available for download at www.pohlcon.com/downloads → Proofs of application.

Corrosion protection in the atmosphere

Corrosivity categories: ISO 12944-2	Profile	Anchors	Bolt, nut, washer	Usage
C1 Low	Rolled, plain	Rolled, plain	Rolled, plain, without corrosion protection	Only possible if all fastening elements are protected by a minimum concrete layer according to Eurocode EC2, depending on the environmental conditions.
C2 Moderate	Hot-dip galvanised (fv), coating ≥ 50 µm	Hot-dip galvanised (fv), coating ≥ 50 µm	Electrogalvanised (gv), coating ≥ 5 µm	Concrete structural elements in interior rooms, e.g. residential apartments, offices, schools, hospitals, sales rooms with the exception of damp rooms.
C3 Medium	Hot-dip galvanised (fv), coating ≥ 50 µm	Hot-dip galvanised (fv), coating ≥ 50 µm	Hot-dip galvanised (fv), coating ≥ 40 µm	Concrete structural elements in interior spaces with normal humidity (including kitchens, bathrooms and laundry rooms in flats) with the exception of the permanent presence of moisture.
C4 High	Stainless steel 1.4401 } A4 1.4404 } 1.4571 } 1.4362 L4	Round anchors: Stainless steel 1.4401 } A4 ¹⁾ 1.4404 } 1.4571 } 1.4362 L4 ¹⁾	Stainless steel 1.4401 } A4-50, 1.4404 } A4-70 1.4571 } 1.4362 L4-70	Applications with medium corrosion resistance, e.g. damp rooms, areas susceptible to weathering, industrial environments, areas near the sea and inaccessible areas.
C5 Very high	Stainless steel 1.4462 FA ²⁾ 1.4529 } HC 1.4547 }	Round anchors: Stainless steel 1.4462 FA ²⁾ 1.4529 HC Weld-on anchor: Rolled, plain ³⁾	Stainless steel 1.4462 FA-70 1.4529 HC-50 1.4547 HC-70	Applications with high corrosion resistance and high corrosion exposure to chlorides and sulphur dioxide (including concentrations of pollutants, e.g. for components in salt water and in road tunnels).

¹⁾ JORDAHL® stainless steel anchor channels with round anchors:

The anchor channel types JTA K 28/15 to JTA W 53/34, JXA W 29/20 to JXA W 53/34 are made with stainless steel round anchors. These anchor channels are not subject to any restrictions in terms of concrete cover.

The anchor channel types JTA W 72/48, JTA K 72/48, JTA W 53/34, JTA K 53/34, JXA W 64/44 and JXA W 53/34 can be produced with round stainless steel anchors or with I-weld-on anchors made of rolled plain steel. The static properties of these round anchors or I-weld-on anchors are equivalent.

²⁾ The designation FA also corresponds to F4.

³⁾ JORDAHL® stainless steel anchor channels with rolled plain round anchors: As corrosion protection for welded anchors, the following concrete cover c must be observed:

Necessary concrete cover c for weld-on anchors

	JTA W 40+	JTA W 50/30 JTA K 50/30	JTA W 53/34 JTA K 53/34 JXA W 53/34 JTA W 50+	JXA W 64/44	JTA W 72/48 JTA K 72/48
Concrete cover c mm	30	45	40	45	60

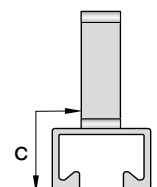

Anchor channels JTA



JORDAHL® anchor channels, together with the matching bolts, offer an excellent fastening system for bearing loads on reinforced concrete components which can be adapted to new fastening requirements at any time. They are an essential part of PohlCon's versatile portfolio and can be used for a wide range of applications.

Maximum planning security

- Safe and reliable fastening thanks to the Eurocode-compatible design concept
- JORDAHL® EXPERT software based on this for the safe and efficient dimensioning of JORDAHL® anchor channels
- Download for free at www.pohlcon.com



Benefits

- Approved throughout Europe **ETA-09/0338**
- Certified with Environmental Product Declaration EPD-JDL-20200260-IBB1-EN
- Fast, efficient and flexible fastening of large loads
- Maintenance-free for decades, as they are made of stainless steel or galvanised steel
- Can be installed without damaging the concrete or reinforcement
- Suitable without restrictions for cracked and non-cracked concrete as well as pretensioned components
- Secure fastening in structural elements with fire protection requirements up to R120
- Increased load-bearing capacity around reinforcement, even in delicate components
- Reduces construction time
- Easy assembly



Overhead lines in tunnels

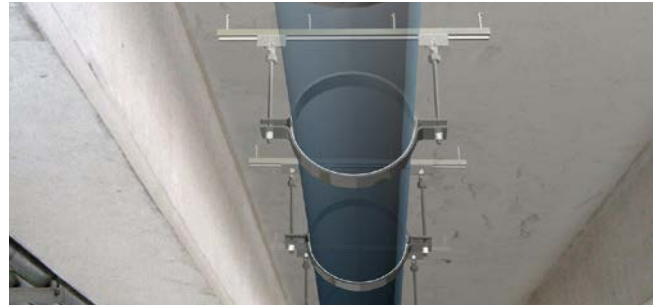

Pipe suspension under bridges



Crane rails/prefabricated supports

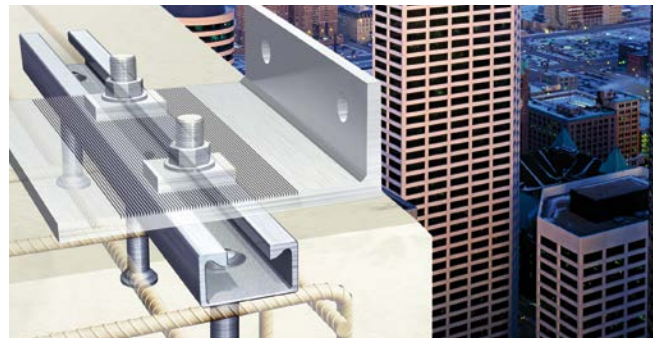

Curtain-wall facades

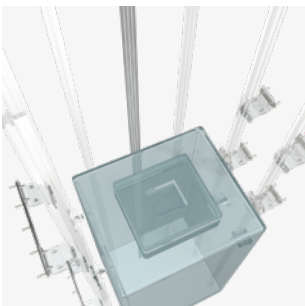

Lift construction



Fastening of stadium seats

Fastening solutions

- Overhead lines in tunnels and along railway lines
- Prefabricated concrete components
- Stadium seats
- Crane rails
- Cable management systems
- Lift guide channels and lift doors
- Industrial machinery
- Curtain-wall facades
- Pipelines

Anchor channels JTA W – for dynamic loads

- Fast, efficient and reliable fastening of heavy loads
- High fatigue strength under dynamic load
- Time- and cost-saving assembly by means of screws without drilling
- Also available in stainless steel for corrosive environments
- Small edge distances possible
- Reusability of the fastening
- Easy compensation of construction tolerances
- Approved almost worldwide
- Suitable for DGNB and LEED certified projects
- Approved for installation in building components with fire protection requirements
- Special lengths on request

Anchor channels JTA K – for static loads

- Fast, efficient and reliable fastening of static loads
- Time- and cost-saving assembly by means of screws without drilling
- Also available in stainless steel for corrosive environments
- Small edge distances possible
- Reusability of the fastening
- Easy compensation of construction tolerances
- Approved almost worldwide
- Suitable for DGNB and LEED certified projects
- Approved for installation in building components with fire protection requirements
- Special lengths on request



Anchor channel JTA W 53/34 with JORDAHL® bolt JB



Anchor channel JTA K 38/17 with JORDAHL® bolt JH

JTA W-CE profile overview¹⁾

Hot-rolled 

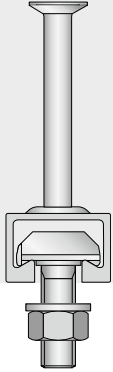
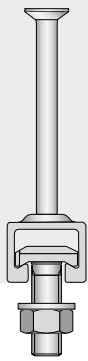
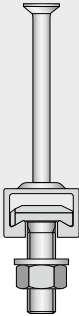
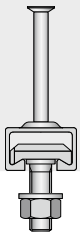
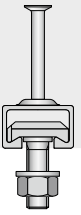
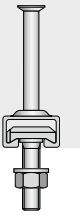
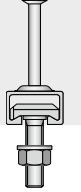



Type	JTA W 72/48-CE	JTA W 55/42-CE	JTA W 53/34-CE	JTA W 50+CE	JTA W 50/30-CE	JTA W 40+CE	JTA W 40/22-CE
Profile drawing							
Profile width mm	72	55	53	50	50	40	40
Profile height mm	48	42	34	30	30	22	22
Installation height: H mm	195	190	170	115	100	100	90
Edge clearance c_{min} ²⁾ mm	150	100	100	75	75	50	50
Matching bolt type	JA	JB	JB	JB	JB	JC	JC
	M20	M16	M10	M10	M10	M10	M10
	M24	M20	M12	M12	M12	M12	M12
	M27	M24	M16	M16	M16	M16	M16
	M30		M20	M20	M20		

¹⁾ Profile dimensions subject to tolerances.

²⁾ When using minimum edge clearances, the load capacities may be reduced, as the load capacity of the concrete becomes decisive.

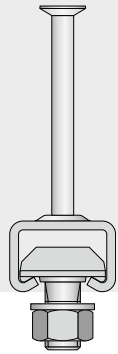
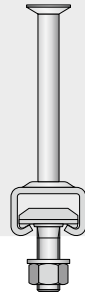
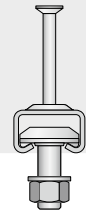
JTA K-CE profile overview¹⁾

Cold-formed 

Type	JTA K 72/48-CE	JTA K 53/34-CE	JTA K 50/30-CE	JTA K 40/25-CE	JTA K 38/17-CE	JTA K 28/15-CE
Profile drawing						
Profile width mm	72	53	50	40	38	28
Profile height mm	48	34	30	25	17	15
Installation height: H mm	195	170	100	90	80	50
Edge clearance c_{min} ²⁾ mm	150	100	75	50	50	40
Matching bolt type	JA	JB	JB	JC	JH	JD
	M20	M10	M10	M10	M10	M6
	M24	M12	M12	M12	M12	M8
	M27	M16	M16	M16	M16	M10
	M30	M20	M20			M12

Version and material of profiles

- Hot-dip galvanised steel (fv)
- Stainless steel (A4)
- Standard filling polyethylene (PE)

Bolt material

- Electrogalvanised (gv) or hot-dip galvanised steel (fv)
- Stainless steel (A4, FA)



Downloads

Did you know that you can easily determine which JORDAHL® anchor channels JTA-CE you need for your specific application using the JORDAHL® EXPERT software? You can download it for free at www.pohlcon.com → Downloads → Digital.

JORDAHL® EXPERT software

Anchor channels



The software enables the user-friendly and safe verification of anchoring loads for anchor channels JTA-CE, JZA-CE and JXA-CE in concrete. The calculations are tailored to your individual design situation, thus enabling you to optimise the products used both from a technical and economic standpoint.

The program is based on European Technical Approval ETA-09/0338. The design software for JORDAHL® anchor channels is compatible with Eurocode 2 (EC2).



Benefits

Intuitive operation

- Simple and straightforward input
- Work directly with the diagram
- No hidden functions
- Clear workflow
- Automatic determination of bolt loads
- Input can be checked directly thanks to real-time updating of results
- Explains what needs to be input via fly-in instructional images

Cost efficiency calculations

- Custom load input
- Automatic edge clearance optimization
- Results overview with component utilization values
- Indication of the relevant proof
- Easy optimisation of the attachment part

Straightforward results

- Easy verification of results
- Output as graphic and text
- Indication of the formulas and parameters used



Downloads

Download the JORDAHL® EXPERT software now for free at www.pohlcon.com → Downloads → Digital!

User-friendly interface

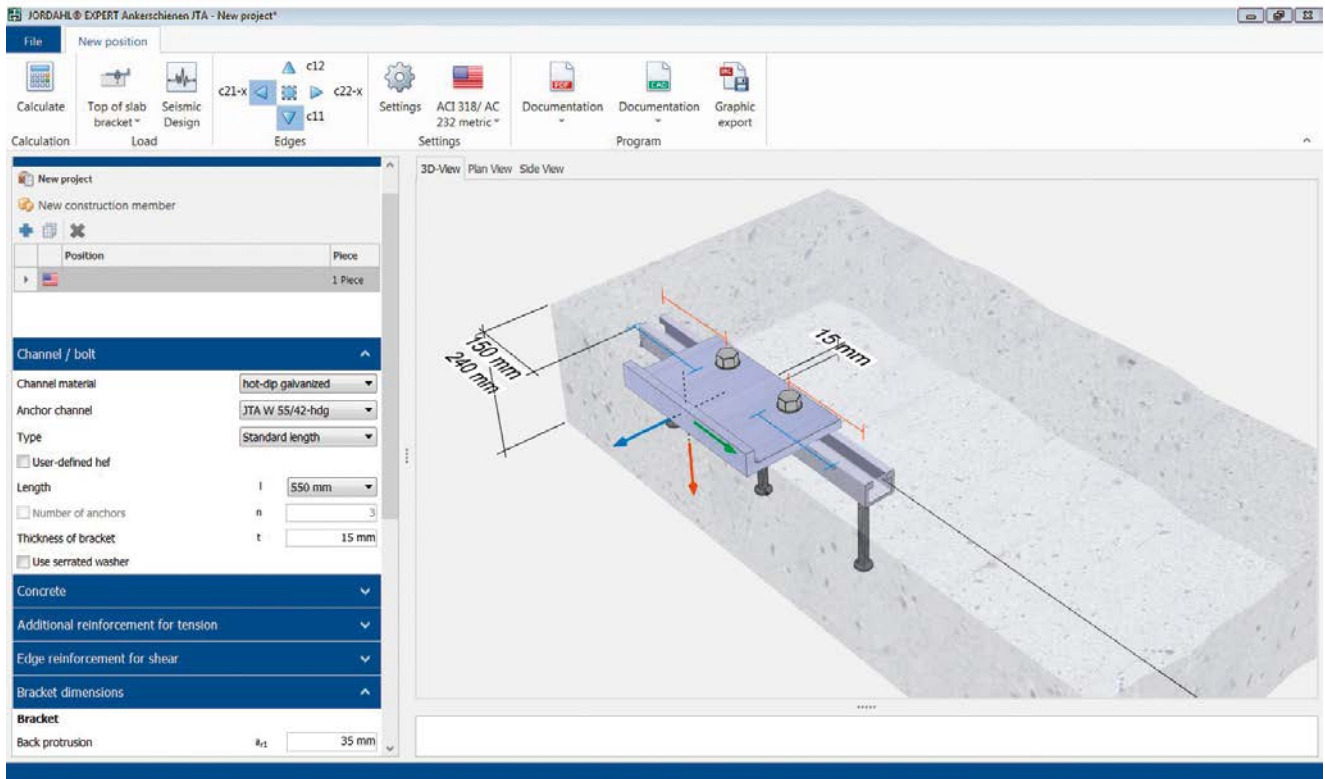

Extra features

Edge reinforcement

With JORDAHL® EXPERT, it is possible to take into account the existing edge reinforcement or selectively added reinforcement in the design of the anchorage and thus increase the load-bearing capacity of the concrete by up to 40%.



Dynamic loads

In addition to static loads, the structural durability can be verified taking into account the amplitude of oscillation.

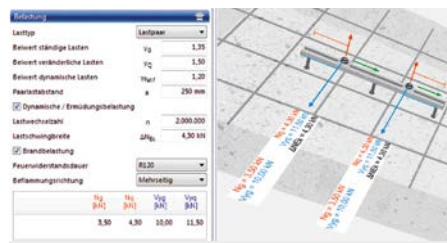

Fire load

For a fire resistance duration of 30 to 120 minutes, the load-bearing capacities under fire load are determined for both single-sided and multi-sided fire loads.



Consultation

Would you like to receive training on the use of JORDAHL® EXPERT software? Feel free to contact our experts by phone on +49 30 68283-802 or by sending an email to tb.jta@pohlcon.com.



Service videos

Learn about the advantages and design possibilities of JORDAHL® EXPERT software from our free software tutorials at www.pohlcon.com → Downloads → Digital → Software

Toothed anchor channels JXA, JZA and JXA-PC



Toothed JORDAHL® anchor channels – in combination with the matching JORDAHL® toothed t-bolts – provide a secure, positive connection without slippage. They are suitable for bearing loads in all directions and offer maximum dynamic load-bearing capacity for non-static loads. A comprehensive standard delivery program ensures that toothed JORDAHL® anchor channels are available for an extremely wide range of fastening requirements.

Maximum planning security

- Safe fastening due to Eurocode compatible design concept
- Planning freedom due to universal load capacity in all directions
- JORDAHL® EXPERT software for safe and efficient design of JORDAHL® anchor channels
- Free download at www.pohlcon.com



Benefits

- Approved throughout Europe **ETA-09/0338**
- Certified with Environmental Product Declaration EPD-JDL-20200260-IBB1-DE
- Fast, efficient and flexible fastening of large loads
- Maintenance-free for decades, as made of stainless steel or galvanized steel
- Installation without damaging the concrete or reinforcement
- Suitable without restrictions for cracked and non-cracked concrete
- Secure fastening in building components with fire protection requirements up to R90
- Increased load-bearing capacity in the vicinity of reinforcement, also in filigree components
- Reduces construction time
- Simple assembly



Curtain-wall facade on Metropolitan building in Poland



Lighting and signalling systems

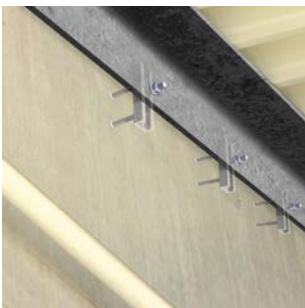

Fastening solutions

- Curtain-wall facades
- Overhead lines in tunnel
- Power plants
- Lift construction
- Lighting and signalling systems
- Cable management systems
- Pipelines
- Prefabricated concrete components



Anchor channels JXA W – for dynamic loads in all directions

- Fast, efficient and reliable fastening of heavy loads in all directions
- High fatigue strength under dynamic load
- Time- and cost-saving installation by means of toothed screws without drilling
- Also available in stainless steel for corrosive environments
- Small edge distances possible
- Reusability of the fastening
- Easy compensation of construction tolerances
- Approved almost worldwide
- Suitable for DGNB and LEED certified projects
- Special lengths on request



Anchor channels JZA K – for static loads in all directions

- Fast, efficient and reliable fastening of static loads in all directions
- Time and cost-saving installation using toothed screws without drilling
- Also available in stainless steel for corrosive environments
- Small edge distances possible
- Reusability of the fastening
- Easy compensation of construction tolerances
- Approved almost worldwide
- Suitable for DGNB and LEED certified projects
- Special lengths on request



Anchor channels JXA-PC W – for seismic loads and safety-relevant applications

- Fast, efficient and reliable fastening of high loads in all directions
- Proven for seismic loads at crack widths up to approx. 1.5 mm
- Time- and cost-saving installation by means of toothed screws without drilling
- Small edge distances possible
- Fire protection up to 90 minutes
- Reusability of the fastening
- Simple compensation of construction tolerances
- Special lengths on request

Profile overview¹⁾ JXA W-CE and JZA K-CE

Hot-rolled



Cold-formed



Type	JXA W 64/44 ³⁾	JXA W 53/34-CE	JXA W 38/23-CE	JXA W 29/20-CE ²⁾	JZA K 41/22-CE
Profile drawing					
Profile width mm	64	53	38	29	41
Profile height mm	44	34	23	20	22
Installation height: H mm	190	170	100	85	90
Matching toothed t-bolt type	JXE	JXB	JXH	JXD	JZS
	M20	M16	M12	M10	M12
	M24	M20	M16	M12	M16

¹⁾ Profile dimensions subject to tolerances.

²⁾ ETA for fv with round anchor

³⁾ ETA (CE) for fv with I-anchor

Profile overview¹⁾ JXA-PC W

Hot-rolled 

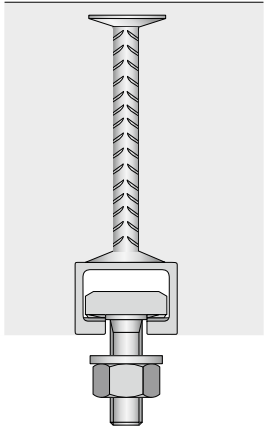
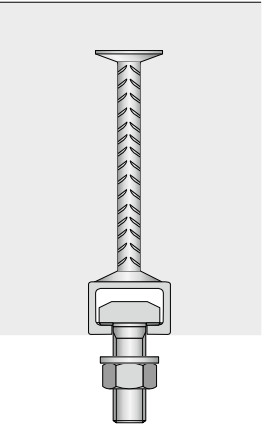
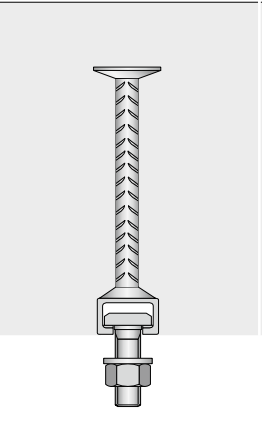
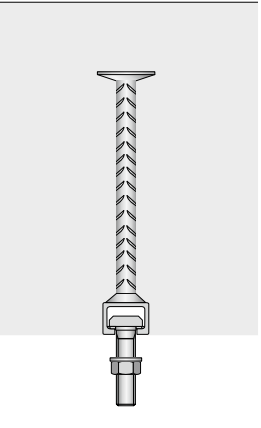
Type	JXA-PC W 64/44	JXA-PC W 53/34	JXA-PC W 38/23	JXA-PC W 29/20 ²⁾
Profile drawing				
Profile width mm	64	53	38	29
Profile height mm	44	34	23	20
Installation height: H mm	200	180	170	165
Matching toothed t-bolt type	JXE	JXB	JXH	JXD
	M20	M16	M12	M10
	M24	M20	M16	M12

¹⁾ Profile dimensions subject to tolerances.

²⁾ Only as hot-dip galvanised version (fv).

Version and material of profiles

- Hot-dip galvanised steel (fv)
- Stainless steel (A4)
- Standard filling polyethylene (PE)

Version and material of bolts

- Electro galvanised (gv) or hot-dip galvanised steel (fv)
- Stainless steel (A4, FA)

Technical data for JXA-PC W

Rated resistances for all concrete strength classes $\geq C30/37$ ¹⁾

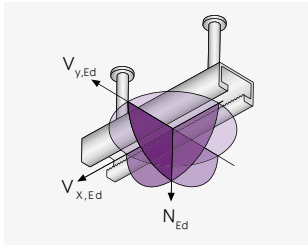

$$\sqrt{N_{Ed}^2 + V_{y,Ed}^2 + V_{x,Ed}^2} \leq F_{Rd} \quad 3)$$

	Matching bolts	Rated resistance F_{Rd} ^{2) 3)} in all load directions kN		
		Single load	Load pairs	
	Toothed t-bolts			
Profile length mm		≥ 100	≥ 200	
Load spacing mm		≥ 250	≥ 50	≥ 150
W 29/20	JXD M10	11.20	6.30 ⁴⁾	9.00 ⁴⁾
	JXD M12			
W 38/23	JXH M12	16.80	9.40 ⁴⁾	12.00 ⁴⁾
	JXH M16			
W 53/34	JXB M16	30.80	–	19.25 ⁶⁾
	JXB M20	26.60 ⁵⁾		
W 64/44	JXE M20	37.80	–	22.40 ⁶⁾
	JXE M24			

- ¹⁾ Applies to concrete with concrete strength class $\geq C30/37$. For concrete strength class C20/25 and C25/30, the minimum clearances must be increased by 1.25 and 1.15 respectively. Alternatively, the rated resistances can be reduced by the reciprocal value.
- ²⁾ If the minimum clearances are observed see table below.
- ³⁾ For simultaneous loads in multiple directions, the resultant load must not exceed the rated load.
- ⁴⁾ Intermediate values may be interpolated.
- ⁵⁾ The value in brackets applies to profiles made of A4.
- ⁶⁾ The minimum load clearance for profile W 53/34 and W 64/44 is 100 mm.

Minimum clearances and dimensions for all concrete strength classes $\geq C30/37$

Profile	Channels						Channel pairs ³⁾		
	a_r mm	a_a mm	a_e mm	a_f mm	b ¹⁾ mm	d_{min} mm	a_{r1} mm	a_{a1} mm	a_{e1} mm
JXA-PC W 29/20	110	220	90	220	220	185	55	110	150
JXA-PC W 38/23	150	300	130	250	300	190	90	180	170
JXA-PC W 53/34	200	400	165	350	400	200	–	–	–
JXA-PC W 64/44	250	500	215	450	500	225	–	–	–

- ¹⁾ Applies to arrangement of a channel.
- ²⁾ Results from the installation height of the anchor channel and the required concrete cover according to DIN EN 1992-1-1:2011-01 and DIN EN 1992-1-1/ NA-2013-04.
- ³⁾ Only permissible for centric tension. Applies to non-cracked concrete. To take the cracked condition into account, the distances a_{r1} and a_{a1} will need to be doubled. Alternatively, the rated resistances can be reduced by a factor of 1.4.

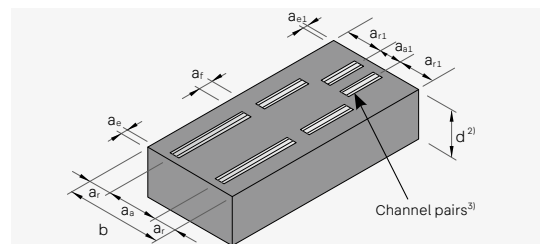

Special features of JXA-PC W

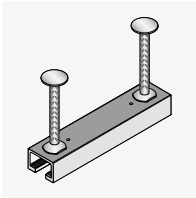

Channel characteristics

JORDAHL® anchor channels JXA-PC consist of a hot-rolled toothed profile and a ribbed anchor with a large undercut head.

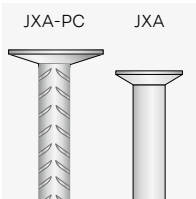

Anchor head and bolt shaft

- The large anchor head guarantees a reliable hold even in large cracks
- The additional anchor length and ribbed surface allow for optimal anchoring in concrete

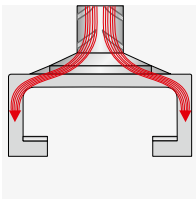

Anchor foot

- Circumferential weld allows for seamless load transfer between anchor and profile

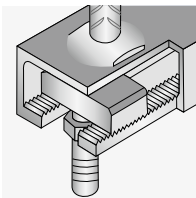

Toothed W-profile

- Hot-rolled profile for high tightening torques
- Toothed channel lips, together with the matching toothed t-bolts, enable a high load capacity in the longitudinal direction of the channel, even in the event of an earthquake

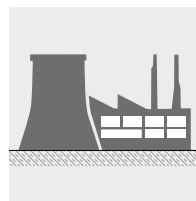
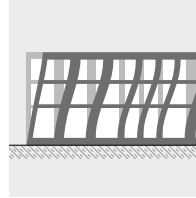

Requirements for safety-relevant applications

Under extreme stress situations such as earthquakes and explosions, it is essential to ensure the functionality of safety-relevant components. The effects of such events necessitate the use of special anchors. The suitability of the anchor channel JXA-PC was verified by simulated seismic tests in 1.5 mm wide concrete cracks. The large anchor head and toothed lips provide very secure and reliable anchorage even in extreme stress conditions.

Extreme stress situations include:

- Earthquake
- Flooding
- Explosions
- Fire
- Airplane crashes, etc.

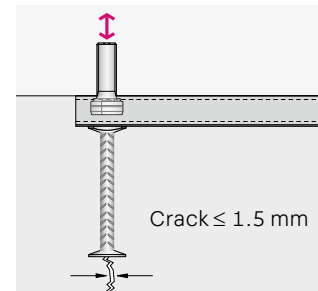

JXA-PC: Maximum safety for exceptional loads and large cracks.

Planning notes

JTA, JXA and JZA ranges

Channel length mm	No. of anchors					
	JTA W 72/48 JTA K 72/48 JTA W 55/42	JXA W 64/44 JXA W 53/34 JXA W 38/23	JTA W 53/34	JTA W 50+ JTA W 50/30 JTA W 40+ JTA W 40/22	JTA K 53/34 JTA K 50/30 JTA K 40/25 JZA K 41/22	JTA K 38/17 JTA K 28/15 JXA W 29/20
100	–	–	–	–	–	2
150	2	2	2	2	2	2
200	2	2	2	2	2	2
250	2	2	2	2	2	2
300	2	2	2	2	2	3
350	2	3	3	3	3	3
400	3	3	3	3	3	–
450	–	–	3	–	–	3
550	3	3	3	3	3	4
800	4	4	4	4	4	5
900	4	–	–	–	–	–
1050	5	5	5	5	5	6
1300	–	–	–	6	–	–
1550	–	–	–	7	–	–
1800	–	–	–	8	–	–
2050	–	–	–	9	–	–
2300	–	–	–	10	–	–
2550	–	–	–	11	–	–
3000	–	–	13	13	13	16
6000	21	25	25	25	25	31
Anchor spacing	≤ 300 mm	≤ 250 mm	≤ 250 mm	≤ 250 mm	≤ 250 mm	≤ 200 mm



JTA W 53/34 -550-3A-fv-CE

Version and material of profiles

- Hot-dip galvanised steel (fv)
- Stainless steel (A4)
- Standard filling polyethylene (PE)

Example order for JORDAHL® anchor channels JTA-CE

Type	Profile size	Channel length mm	Anchors	Version	ETA-compliant
JTA W	53/34	– 550	– 3A	– fv	– CE

Example order for JORDAHL® anchor channels JXA

Type	Profile size	Channel length mm	Version
JXA W	38/23	– 250	– fv

Fire load

JORDAHL® anchor channels JTA and JXA can also be used in structural elements made of normal concrete with fire protection requirements R30 to R120 according to EC2 (DIN EN 1992-1-2). Only static loads perpendicular to the

longitudinal axis of the channel, such as central tension/ oblique tension and transverse tension, are permissible (no longitudinal tension).

Required concrete cover and edge clearance for fire protection requirements R30 to R120 for JTA and JXA

Profile		Concrete cover a^1 mm				Edge clearance $c_{min,fi}^2$
JTA ¹⁾	JXA ¹⁾ /JXA-PC	R 30	R 60	R 90	R 120	
JTA K 28/15 JTA K 38/17	-	35	35	45	60	$\geq 2.0 h_{ef}$ $\geq 300 \text{ mm}^2$
JTA W 40+ JTA W 40/22 JTA K 40/25	-	35	35	45	60	$\geq 2.0 h_{ef}$ $\geq 300 \text{ mm}^2$
JTA W 50+ JTA W 50/30 JTA K 50/30	-	35	35	45	60	$\geq 2.0 h_{ef}$ $\geq 300 \text{ mm}^2$
JTA W 53/34 JTA K 53/34	-	50	50	50	65	$\geq 2.0 h_{ef}$ $\geq 300 \text{ mm}^2$
JTA W 55/42 JTA W 72/48 JTA K 72/48	-	50	50	50	70	$\geq 2.0 h_{ef}$ $\geq 300 \text{ mm}^2$
-	JXA W 29/20 JXA-PC W 53/34	-	35	45	-	$\geq 2.5 h_{ef}$ $\geq 300 \text{ mm}$
-	JXA W 38/23 JXA-PC W 53/34	-	35	45	-	$\geq 2.5 h_{ef}$ $\geq 300 \text{ mm}$
-	JXA W 53/34 JXA-PC W 53/34	-	50	50	-	$\geq 2.5 h_{ef}$ $\geq 300 \text{ mm}$
-	JXA W 64/44 JXA-PC W 64/44	-	50	50	-	$\geq 2.5 h_{ef}$ $\geq 300 \text{ mm}$

¹⁾ For more information, see ETA-09/0338.

²⁾ Only for multi-sided fire load.

Reinforced concrete slabs made of normal concrete with JORDAHL® anchor channels embedded in concrete.

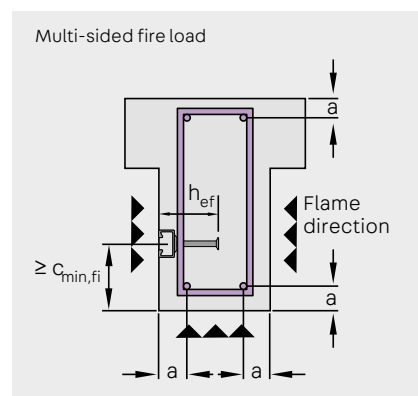
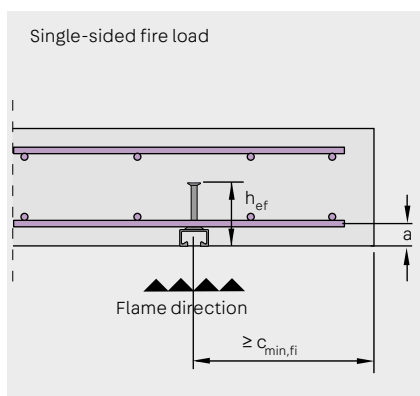

Downloads

For the dimensioning of JORDAHL® anchor channels JTA according to ETA-09/0338 and TR 020 taking into account steel and concrete failure modes, our easy-to-use software JORDAHL® EXPERT is available to download for free at www.pohlcon.com → Downloads → Digital.

Dynamic loads

Due to their specific manufacturing process, hot-rolled JORDAHL® anchor channels JTA W are particularly suitable for bearing dynamic loads and/or loads which are not predominantly static. A cost-effective design for any number of load cycles is possible with ETA-09/0338.

Verification for fatigue

- The verification is carried out according to EN 1992-1-1 (EC2), 6.8.3 in the fatigue limit state for fatigue-inducing stresses under working loads.
- To calculate the amplitude of oscillation, a subdivision must be made into non-cyclic and cyclic fatigue-inducing stresses, i.e. underload and overload.
- The basic combination of non-cyclic stresses corresponds to the frequent stress combination in the serviceability limit state.
- The cyclic stress is to be combined with the unfavourable basic combination.



Lift shaft

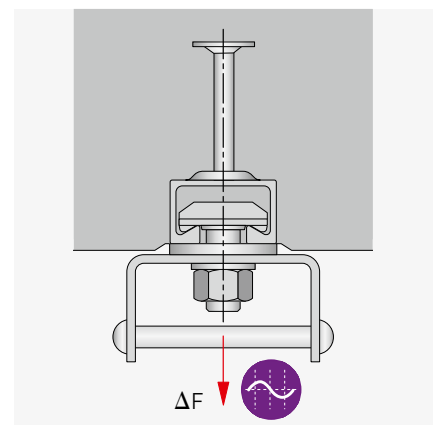
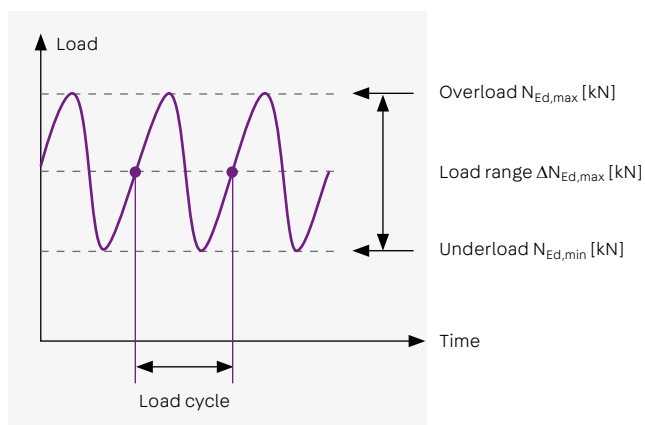

Verification format:

$$\frac{\Delta N_{Ed}}{\Delta N_{Rd}} \leq 1$$

Fatigue resistance for underload = 0

The fatigue resistance for loads with underloads equal to zero can be read off directly from the Wöhler line according to ETA-09/0338 for any number of load cycles.

Fatigue resistance $\Delta N_{Rd,0}$ kN

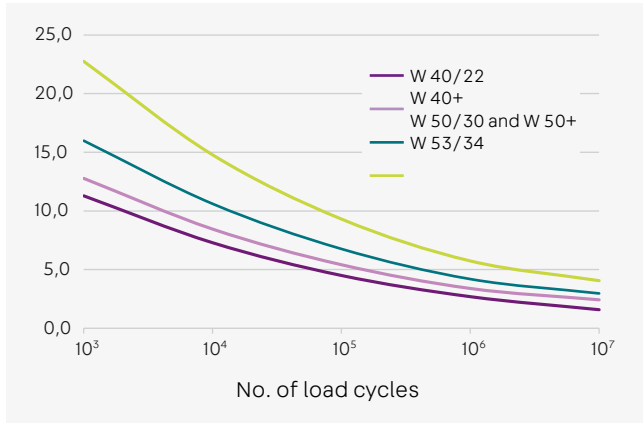

Profile	No. of load cycles		
	10 ⁶	2 · 10 ⁶	>10 ⁸
JTA W 40/22	2.7	2.3	–
JTA W 40+	3.4	2.9	2.4
JTA W 50/30	4.2	3.6	3.0
JTA W 50+	4.2	3.6	3.0
JTA W 53/34	5.7	4.9	4.1

Fatigue resistance for underload ≥ 0

The fatigue resistance for stresses with underloads greater than zero is derived from the Wöhler line for defined numbers of load cycles using the Goodman diagram.

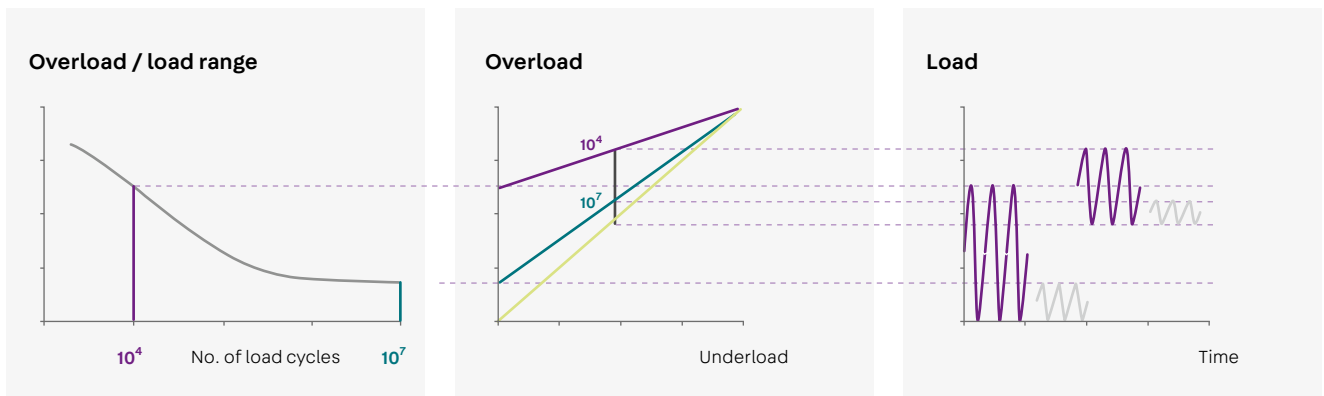

Fatigue resistance for underload = 0

Fatigue resistance for underload ≥ 0 (defined no. of load cycles)

$$\Delta N_{Rd} = \Delta N_{Rd,0} \cdot \left(1 - \frac{N_{Ed,min}}{N_{Rd}} \right)$$

Combination of anchor channels and bolts for fatigue-inducing fluctuating tensile stress

Profile	Hook-head t-bolt		
	Type	Strength	Surface
JTA W 40/22 JTA W 40+	JC M12	8.8	gv fv
	JC M16	4.6 8.8	
JTA W 50/30 JTA W 50+	JB M16	4.6	
	JB M20	8.8	
JTA W 53/34	JB M16	8.8	
	JB M20		



Notes

The verification for fatigue in JXA profiles is carried out according to the rules of ETA 09/0338. For further information, please contact the technical advisory service - by phone at +49 30 68283-802 or by e-mail to: tb.jta@pohlcon.com.

Installation

PohlCon supplies anchor channels from JORDAHL in all desired lengths. To prevent fresh concrete from entering the profile, JORDAHL® anchor channels are filled with

polyethylene foam (PE). PE foam can easily be removed after concreting.

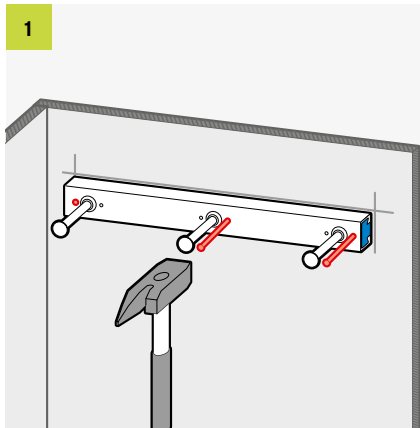

Making the connections

JORDAHL® anchor channels are installed based on the reinforcement and/or formwork plans. To prevent shifting during concreting, the channels are fixed in place:

- in the case of wooden formwork, by nailing through the nail holes on the rear of the profile (1)
- in the case of steel formwork, by gluing with hot-melt adhesive, by bolting with JORDAHL® bolts or with magnets (2)
- on the top of a concrete slab by tying the anchors to the reinforcement or, if necessary, by using special spacers that are attached to the anchors with spot welds.

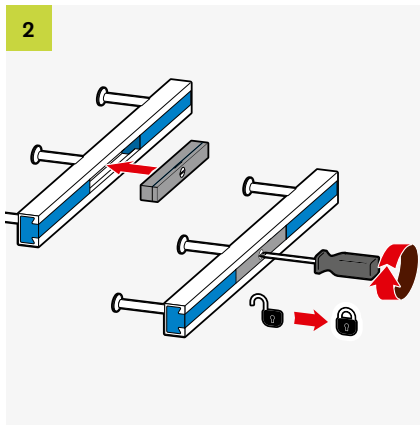

Before concreting

Once the anchor channels have been attached to the formwork, concrete can be poured. Care must be taken to ensure that the concrete is properly compacted around the channel and anchors.

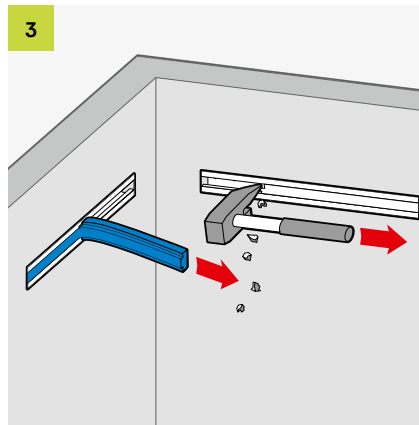

Removing the foam filling

Once the concrete has hardened, the formwork is removed. The anchor channel is flush with the concrete. The foam filling can easily be removed using a hammer or other tools.

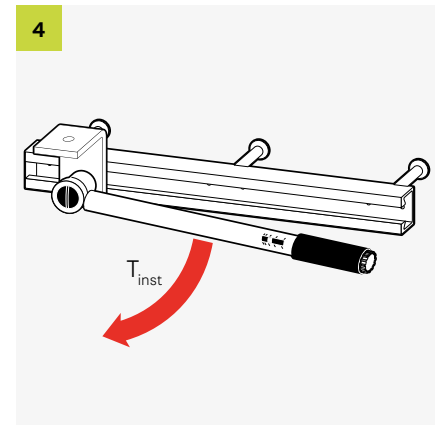

Bolt installation

JORDAHL® bolts can now be inserted at any point in the slot of the anchor channel and, after a 90° turn, tightened to the appropriate tightening torque (see table). The control slot on the shaft of the bolt must point transversely to the direction of the channel (see "Position marking" page 49).

Assembly

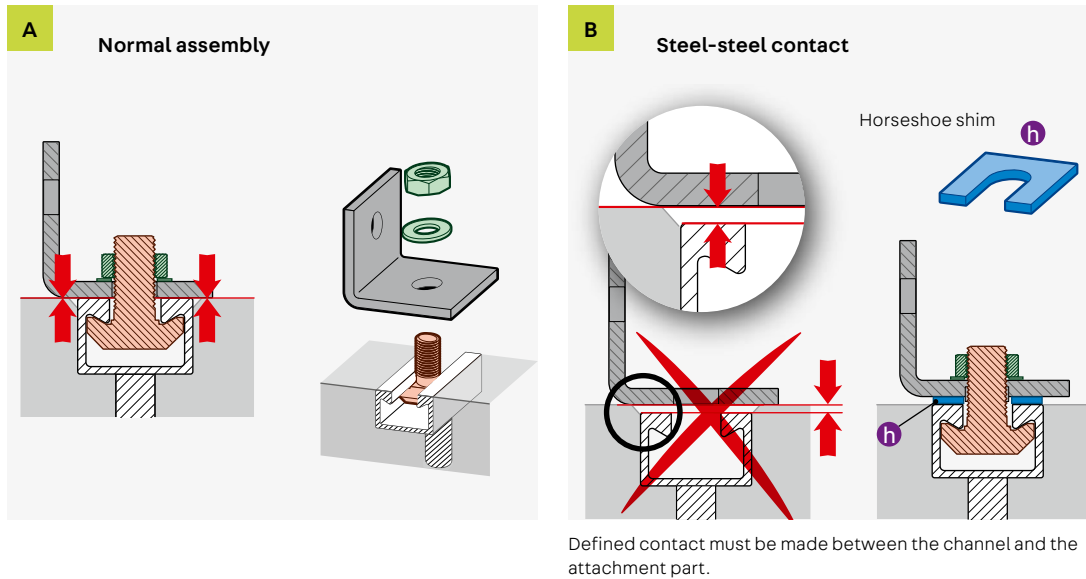

Tightening torque

Type	Bolt Ø	Tightening torque T_{inst} [Nm (lb-ft)]	
		Normal assembly A	Steel-steel contact B
		Material	Material
		4.6, 8.8, A4-50, HC-50, A4-70, HC-70, FA-70, L4-70	8.8, A4-70, HC-70, FA-70, L4-70
JD	M6	-	3 (2.5)
JD	M8	8 (6)	20 (15)
JB, JC, JH, JD	M10	13 ¹⁾ (10) ¹⁾ , 15 (11)	40 (30)
JXD, JXH		-	40 (30)
JB, JC, JH, JD	M12	15 ¹⁾ (11) ¹⁾ , 25 (19)	70 (52)
JXD, JXH		-	80 (59)
JZS		-	50 (37)
JB, JC, JH	M16	40 ²⁾ (30) ²⁾ , 45 ³⁾ (34) ³⁾ , 60 ⁴⁾ (45) ⁴⁾	180 (133)
JXH		-	120 (89)
JXB		-	200 (148)
JKB, JKC		-	180 (133)
JZS		-	90 (67)
JA, JB		75 ⁵⁾ (56) ⁵⁾ , 120 (89)	360 (266)
JXB, JXE	M20	-	350 (259)
JKB		-	360 (266)
JA, JB, JE	M24	200 (148)	620 (458)
JXE		-	450 (332)
JA	M27	300 (222)	900 (664)
JA	M30	380 (281)	1200 (885)

¹⁾ JD, ²⁾ JH, ³⁾ JC, ⁴⁾ JB, ⁵⁾ JB for K 50/30; W 50/30; W 50+

Anchor channels – Custom solutions

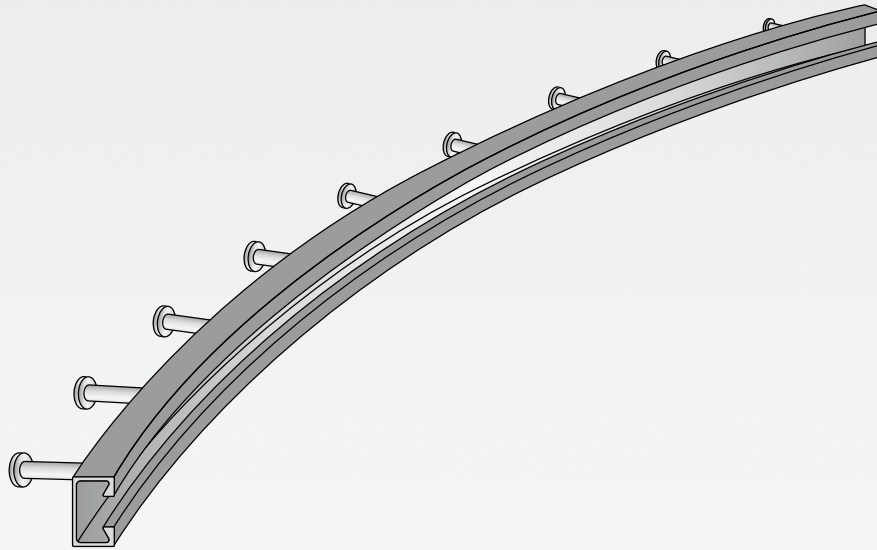

JORDAHL® channels are as versatile as their application possibilities. That is why we also offer numerous anchor channels for highly specialised fastening requirements. Anchor channels for extremely high static and dynamic loads are available, as well as anchor channel corner pieces, anchor channel pairs and curved anchor channels, which are suitable for applications in tunnel construction, among others.

For railing and facade fastening, hot-rolled and cold-formed channels are available. Channels with welded-on reinforcing bars are suitable for high transverse loads and reduced edge clearances, but also for shallow component depths. Together with the appropriate bolts, our custom solutions offer a fast and secure fastening solution - even for your highly specialised applications.

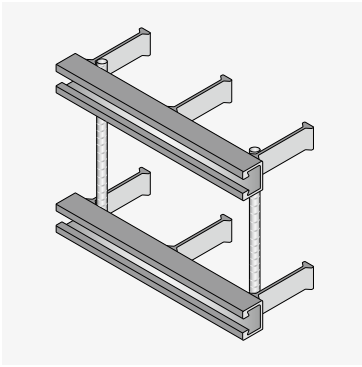

JORDAHL® anchor channel pairs

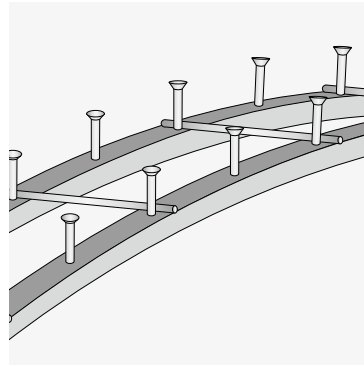

JORDAHL® curved anchor channels

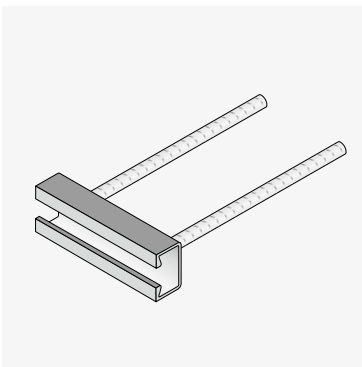

JORDAHL® railing fastening channels JGB

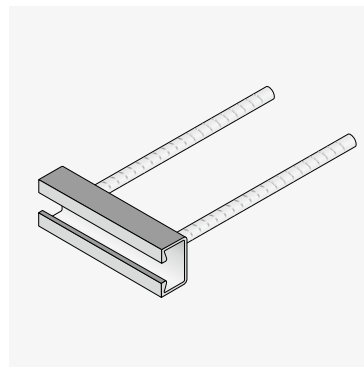

JORDAHL® facade fastening channels JTA-RF

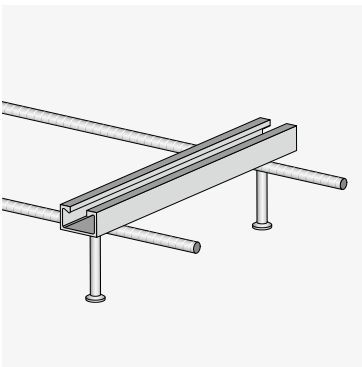

JORDAHL® facade fastening channels JTA-RT

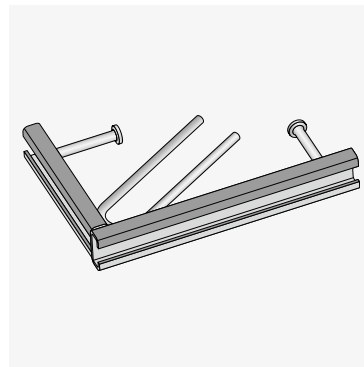

JORDAHL® anchor channel corner pieces

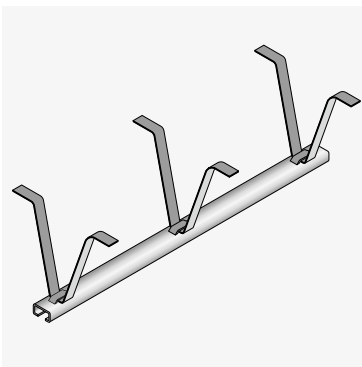

JORDAHL® anchor channels JSA

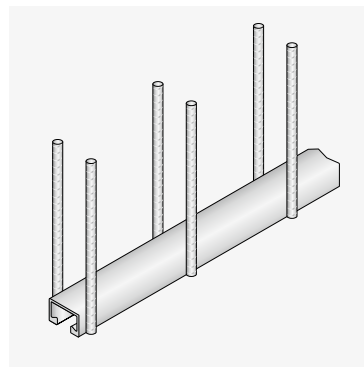

JORDAHL® anchor channels JRA

Anchor channel pairs

A typical application for anchor channel pairs is the fastening of glass or metal facades. JORDAHL® anchor channel pairs are tailor-made for each individual project. The reinforcement serves as a spacer.

Example order for anchor channel pairs

Type	Profile	Length mm	Anchors	Version	ETA- compliant	Channel centre spacing mm
JTA	W 53/34	400	3A	fv	CE	e = 250

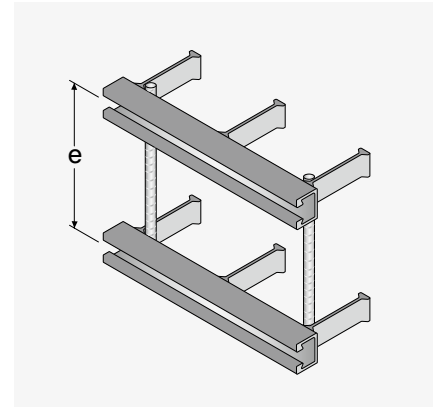

Curved anchor channels

For curved utility shafts, processing plants or in tunnel construction, JORDAHL offers pre-bent anchor channels. The anchor channels can have a concave (profile slot on the inside) or convex (profile slot on the outside) curve. This is done

with high precision, as is the case, for example, with anchor channels for segments in tunnel construction. They are tested with gauges provided by the customer.



Curved anchor channels are used all over the world for fastening overhead lines in railway tunnels.

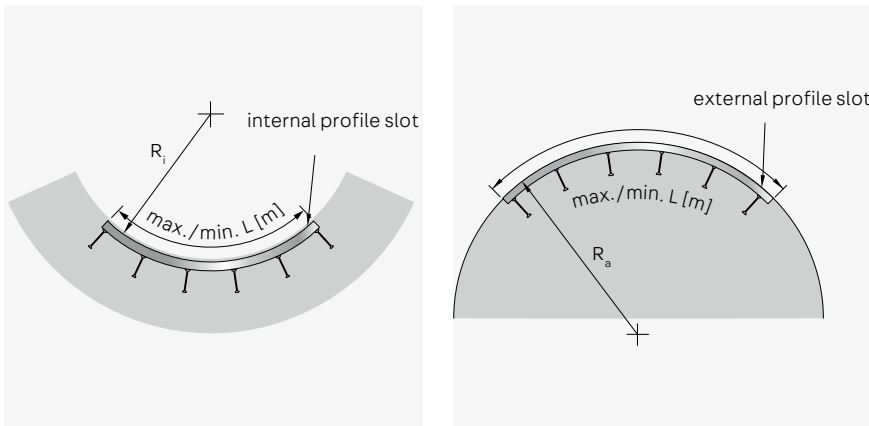

Minimum bending radii and channel lengths (all materials)

Profile	JTA/JM						JXA/JXM		
	K 72/48 W 72/48	W 55/42	K 53/34 W 53/34	K 50/30 W 50/30 W 50+	K 40/25 W 40/22 W 40+	K 38/17	K 28/15	W 38/23	W 29/20
min. R_i ¹⁾ m	1.0	0.5	0.5	0.5	0.5	0.5	0.5	0.5	0.5
min. R_a m	3.0	3.0	2.5	2.0	2.0	1.5	1.0	2.0	2.0
min. L m	1.5	1.5	1.5	1.5	1.0	0.5	0.5	0.5	0.5
max. L m	5.5	5.5	5.6	5.6	5.6	5.6	5.6	5.6	5.6

¹⁾ Maximum lengths are not possible with minimum radii. Contact for inquiries: Technical consultation on +49 30 68283-802 or send an e-mail to tb.jta@pohcon.com

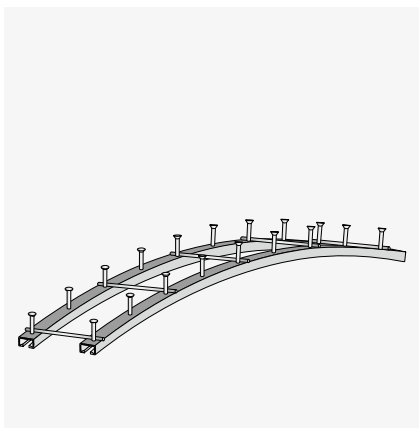

Curved anchor channel pair with welded spacers.

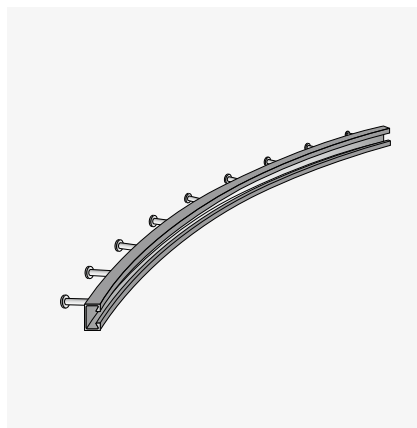

Curved anchor channel for tunnel construction

Example order for curved anchor channel for tunnel construction

Type	Profile	Covered length mm	Anchors	Version	ETA-compliant	Bending radius m
JTA	W 53/34	1050	5A	fv	CE	$R_i = 4.30$

Railing fastening channels JGB

JORDAHL® railing fastening channels ensure the safe and quick fastening of railing posts to the end faces of concrete slabs. The system consists of short anchor channel pieces, which are

embedded directly in the balcony slab, and the corresponding JORDAHL® bolts.



Benefits

- Extra long rebars for secure anchoring
- Easy assembly and adjustment of railing connections with one or two screw/s
- For concrete slabs from 100 mm thickness
- Flexible connections with one or two screws
- No damage to the components by drilling
- Reusability of the fastening
- Good integration in heavily reinforced structural elements
- Special lengths on request

Version and material

- Hot-dip galvanised steel (fv) for interior applications
- Stainless steel (A4) for outdoor applications with efficient corrosion protection
- Standard filling polyethylene (PE)

Type	JGB K 53/34	JGB K 50/30	JGB K 40/25	JGB K 38/17
Profile drawing				
Profile width mm	53	50	40	38
Profile height mm	34	30	25	17
Installation height: H mm	320	225	200	165
Matching bolt type	JB	JB	JC	JH
	M16	M12	M12	M12
	M20	M16	M16	M16
		M20		

Range JGB

Type	JGB G			JGB G – corners ³⁾			Matching bolts ⁴⁾
Anchor JGB G BSt made of straight rebar							
	Dimensions mm			Dimensions mm			
Profile	Profile length	Anchor Ø	Installation height H _{max}	Profile length	Anchor Ø	Installation height h _A	Type x Dimension Material
JGB K 38/17-G	100 ¹⁾ , 150, 200, 250	10	165	170/170	10	200	JH M12×40 – A4-50/4.6 GV JH M16×40 – A4-50/4.6 GV
JGB W 40/22-G JGB K 40/25-G	100 ¹⁾ , 150, 200, 250	12	200	170/170	12	240	JC M12×40 – FA-70/8.8 FV JC M16×40 – FA-70/8.8 FV
JGB W 50/30-G JGB K 50/30-G	100 ¹⁾ 150, 200, 250	12	225	170/170	12	240	JB M12×40 ²⁾ – FA-70/ 8.8 FV JB M16×50 – FA-70/8.8 FV JB M20×55 – FA-70/ 8.8 FV
JGB W 53/34-G JGB K 53/34-G	100 ¹⁾ 150, 200, 250	14	320	170/170	14	360	JB M16×50 – FA-70/8.8 FV JB M20×55 – FA-70/8.8 FV

¹⁾ Channel length only possible for fastening with one bolt.

²⁾ Profile W 50/30 only approved for fastening with two bolts.

³⁾ Not within scope of national technical approval.

⁴⁾ If smaller bolts are used, the rated resistance of the bolts in accordance with Z-21.4-1913, Annex 8 must not be exceeded.

Anchor shapes for small component depths

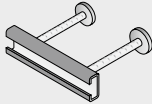
JGB DA Anchor BSt with one-sided head	Profile	Profile length mm	Anchors Ø	Installation height H mm
	JGB K 38/17-DA ⁶⁾	100 – 250	10	120
	JGB K 40/25-DA ⁵⁾	100 – 250	10	125
	JGB K 50/30-DA ⁵⁾	100 – 250	12	150
	JGB K 53/34-DA ⁵⁾	100 – 250	14	250

⁵⁾ Hot profile version also available. ⁶⁾ Only as hot-dip galvanised version (fv).

Example order for railing fastening channel

Type	Profile	Length mm	Version
JGB	K 38/17-G	200	A4

Facade fastening channels JTA-RF and JTA-RT

JORDAHL® facade fastening channels enable the fastening of heavy curtain wall elements to the ceiling slabs of skyscrapers. JTA-RT channels are installed in the top of the slab, JTA-RF channels in the face. For applications with high shear loads and reduced edge clearances, the JORDAHL® anchor

channels JTA-RT and JTA-RF with welded-on reinforcement bars provide optimum tie-back of shear loads into the concrete, for example for facade applications close to the edge. The length of the channels and the number of anchors can be individually adapted to the requirements of the project.



JTA-RT



Benefits

- Fastening of heavy curtain wall elements to the ceiling slabs of skyscrapers.
- Adjustability parallel to the edge of the ceiling slab for fast installation and compensation of design tolerances
- Short edge clearance to reduce the size of the attachment part
- Extremely high wind loads in compression and suction direction
- Suitable for delicate prestressed concrete ceiling slabs thanks to low installation height
- Attachment to the top of the ceiling slab
- Installation within a recess for level floor construction

Version and material

- Hot-dip galvanised steel (fv) for interior applications
- Stainless steel (A4) for outdoor applications with efficient corrosion protection
- Standard filling polyethylene (PE)

JTA-RF range

JTA-RF anchor BSt made of straight rebar

Profile

Profile length
mm

Anchors
Ø

Installation height: H
mm

	JTA-RF W 40/22	150, 300, 350	10	330
	JTA-RF W 50/30	150, 300, 350	12	340
	JTA-RF W 53/34	150, 300, 350	14	420

Example order for facade fastening channels

Type	Profile	Length mm	Version
JTA-RF	JW 50/30	300	A4

JTA-RT range

JTA-RT round anchors and BSt reinforcement

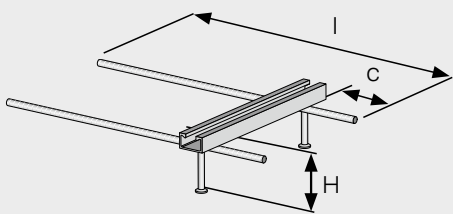
	Profile	Variant	Profile length mm	c mm	l mm
	JTA-RT W 40/22 Installation height H = 90 mm	1	150 - 550	50	340
		2	150 - 550	75	365
		3	150 - 550	100	390
		4	150 - 550	125	415
		5	150 - 550	150	440
		6	150 - 550	175	465
		7	150 - 550	200	490
	JTA-RT W 50/30 Installation height H = 100 mm	1	150 - 550	75	365
		2	150 - 550	100	390
		3	150 - 550	125	415
		4	150 - 550	150	440
		5	150 - 550	175	465
	JTA-RT W 53/34 Installation height H = 170 mm	1	150 - 550	100	400
		2	150 - 550	125	425
		3	150 - 550	150	450
4		150 - 550	175	475	
5		150 - 550	200	500	

Example order for JTA-RT

Type	Profile	Variant	Length mm	Version
JTA-RT	W 40/22	01	200	fv



Downloads

For planning JORDAHL® anchor channels JTA-RF and JTA-RT, we provide you with the convenient and intuitive JORDAHL® EXPERT design software. You can download it for free at www.pohlcon.com → Downloads → Digital.

Anchor channel corner pieces

Anchor channel corner pieces are used to attach brackets to curtain-wall facades. Special versions can also be supplied upon request.

Example order for anchor channel corner piece

Type	Profile	Length mm	Version
JTA	K 38/17	125 x 250	A4

Range

JTA profile	Leg length mm
K 38/17	125 x 250
	150 x 250
	200 x 200
K 50/30	250 x 250
	300 x 300
W 50/30	250 x 250
	300 x 300
K 53/34	250 x 250
	300 x 300
W 53/34	250 x 250
	300 x 300



Anchor channels JSA

JORDAHL® anchor channel JSA consist of profiles with loop openings and matching anchoring stirrups made of sheet metal strips, which can be installed on site and easily bent into shape by hand.

Areas of application

JORDAHL® anchor channels JSA are designed specifically for fastening non-load-bearing structures. Anchoring may only be carried out in reinforced normal concrete of strength class $\geq C12/15$.

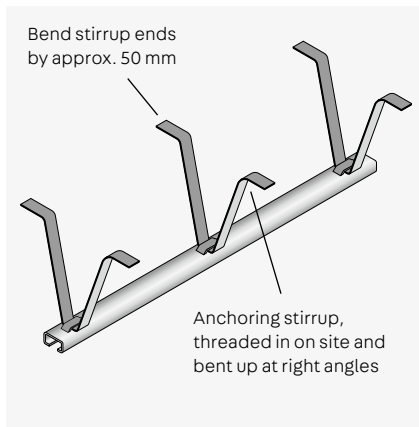

JSA anchor channel with mounted stirrups

Installation

The anchoring stirrups are inserted through the loop openings at intervals of 250 mm and bent into shape (see illustration). In case of holes at intervals of 125 mm, stirrups are mounted only in every second loop. In any case, one anchoring stirrup must be installed at the beginning and at the end of the channel.

Available lengths and anchor layouts

Available length 5960 ±60 mm

Anchor spacing

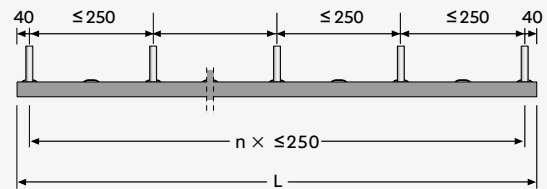

Profile types and technical data

JSA profile	Weight ¹⁾ of the channel with anchor kg/m	Fastening elements		Channel		Anchoring stirrup t × b × l mm
		Bolt	Locking plate	Material	Version	
<p>K 38/17</p>	2.3	JH M10-M16	JGM H M5-M12	Steel	Rolled, plain, hot-dip galvanised	2 × 20 × 400
<p>K 28/15</p>	1.34	JD M6-M12	JGM D M4-M10	Steel	Rolled, plain, hot-dip galvanised	1.5 × 15 × 320

¹⁾Weight per metre for rolled, plain version. For galvanised profiles, the following applies: Weight per meter × 1.10

Example order for JSA

Type	Profile	Channel length mm	Version
JSA	K 38/17	5,960	fv



Consultation

Do you have any questions about load-bearing capacities, installation spacing and areas of application of JORDAHL® anchor channels JSA? Our experts will be happy to help you – send an email to tb.jta@pohlcon.com or call us on +49 30 68283-802.

Mounting channels JM, JXM and JZM



JORDAHL® mounting channels offer you the greatest possible safety and flexibility: Together with the matching JORDAHL® bolts, they form a reliable channel-bolt connection that can be adapted to new load-bearing and fastening requirements at any time. They can be welded on directly or bolted to frame constructions.

Maximum planning security

- Suitable for medium to heavy-duty structures, e.g. supporting frames and bolted connections subjected to high loads
- For variable bolt spacing in longitudinal channel direction and for tolerance compensation for attachment parts
- Pre-bent mounting channels, double profiles, cold-formed mounting (hole) channels upon request.



Benefits

- Approved throughout Europe **ETA-15/0386**
- Certified with Environmental Product Declaration EPD-JDL-20200260-IBB1-EN
- Rapid replacement, retrofitting and relocation of components and structural elements
- Free positioning and stepless adjustment with simple assembly tool
- Compensation for construction tolerances and changing to a different standard grid possible
- Rapid disassembly of attachment parts
- Fire protection
- Shorter construction time



Vehicle construction



Shipbuilding



Fastening of lift doors in a lattice beam shaft

Fastening solutions

- Rail vehicle construction
- Shipbuilding
- Tunnel construction
- Power plant construction
- Lift construction
- Vehicle construction
- Machine and plant construction
- Steel and industrial construction
- Energy and building services engineering



JM W



JXM W



JM K, JZM K



JML K, JZML K

Hot-rolled mounting channels

JM W and JXM W

- Fast, efficient and reliable fastening of heavy loads (also in longitudinal channel direction with JXM W)
- Dynamic load capacity
- Economical series production due to shorter planning and installation times
- Available in stainless steel for corrosive environments
- JXM W: Directly weldable
- Variable screw spacing in longitudinal channel direction
- Free positioning and stepless adjustment
- Rapid replacement, retrofitting, relocation of components
- Approved almost worldwide
- Suitable for DGNB and LEED certified projects

Cold-formed mounting channels

JM K, JML K, JZM K and JZML K

- Fast, efficient and reliable fastening of high loads (in all directions with JZM K).
- Economical series production due to shorter planning and installation times
- Available in stainless steel for corrosive environments
- JML K: Can be screwed on directly
- Constant material thickness
- Variable screw spacing in longitudinal direction of channel
- Free positioning and stepless adjustment
- Rapid replacement, retrofitting, relocation of components
- Suitable for DGNB and LEED certified projects
- Used, among other things, for the trouble-free fastening of supply and disposal lines, electric cables, cable or air-conditioning ducts

Profile overview: Hot-rolled mounting channels

The mounting channels of the hot-rolled profile series JM W are characterised by:

- Solid channel lips, large contact surfaces and high tightening torques
- Right-angled profile edges and low residual stresses, for good weldability

Version and material

- **wb** = Rolled, plain
- **fv** = Hot-dip galvanised
- **A4** = Stainless steel 1.4401/1.4404/1.4571

Mounting channels JM W (ETA 15/0386)³⁾

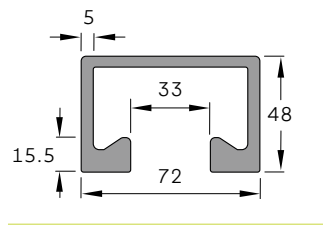
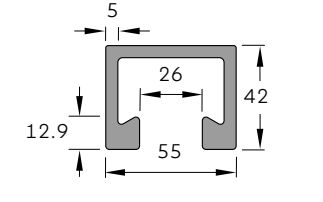
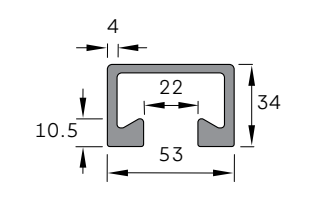
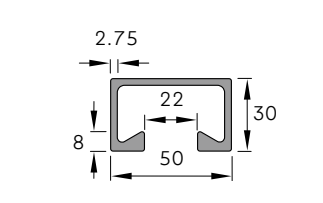
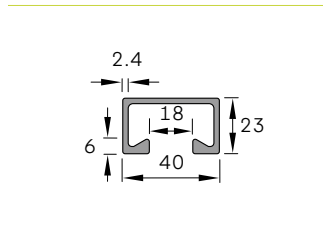
	<p>Profile JM W 72/48¹⁾</p> <p>wb, fv, A4 Bolt JA M20 - M30 Locking plate JGMA M20</p>
	<p>Profile JM W 55/42²⁾</p> <p>wb, fv Bolt JB M10 - M24 Locking plate JGMBM6 - M16</p>
	<p>Profile JM W 53/34</p> <p>wb, fv, A4 Bolt JBM10 - M20 Locking plate JGMBM6 - M16</p>
	<p>Profile JM W 50/30</p> <p>wb, fv, A4 Bolt JBM10 - M20 Locking plate JGMBM6 - M16</p>
	<p>Profile JM W 40/22</p> <p>wb, fv, A4 Bolt JC M10 - M16 Locking plate JGMBM6 - M16</p>

Mounting channels JXM W³⁾

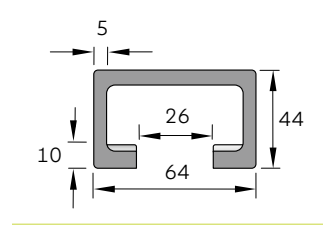
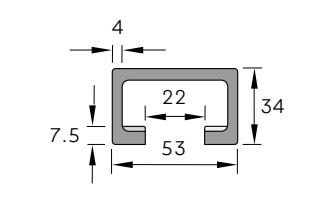
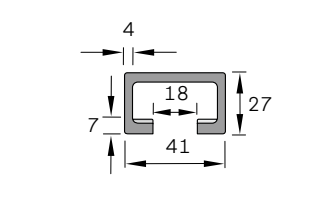
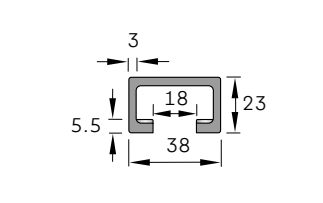
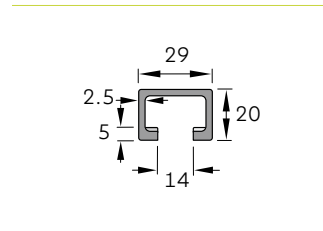
	<p>Profile JXM W 64/44</p> <p>wb, fv Toothed t-bolt JXE M20 - M24</p>
	<p>Profile JXM W 53/34</p> <p>wb, fv, A4 Toothed t-bolt JXB M16 - M20</p>
	<p>Profile JXM W 41/27</p> <p>wb, fv Toothed t-bolt JXH M12 - M16</p>
	<p>Profile JXM W 38/23</p> <p>wb, fv, A4 Toothed t-bolt JXH M12 - M16 Tee-head bolt JHM16</p>
	<p>Profile JXM W 29/20</p> <p>wb, fv Toothed t-bolt JXD M12 Tee-head bolt JDM12</p>

¹⁾ JM W 72/48 corresponds to JM W 74/48.

²⁾ JM W 55/42 corresponds to JM W 54/43.

³⁾ Profile dimensions subject to tolerances.

Example order for JM mounting channel

Type	Profile	Channel length mm	Version
JM	W 50/30 -	6.000	fv

Rated resistances for JM W and JXM W

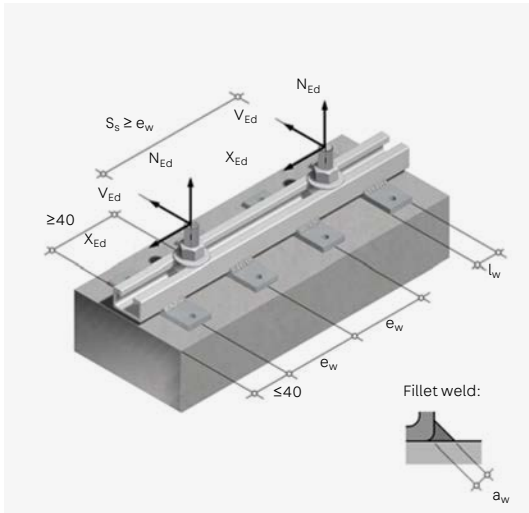

Dowelled mounting channel

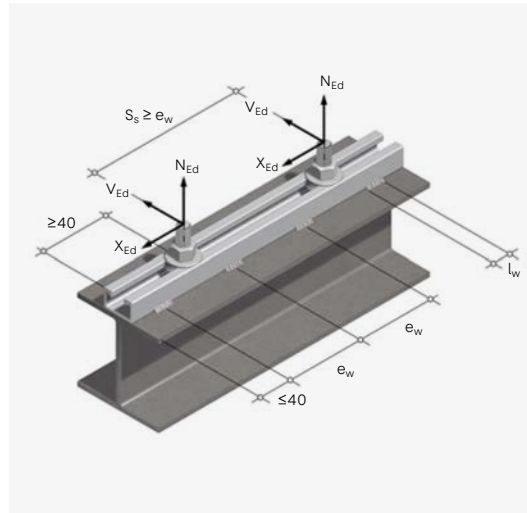

Welded mounting channel

Profile	Weld seams			Rated resistances ¹⁾			Bolts	
	a _w mm	l _w mm	e _w mm	N _{Rd} kN	V _{Rd} kN	X _{Rd} kN	Type	Min. spacing S _s mm
JM W72/48	5	50	300	65.8	24.0	–	JA M24	300
JM W55/42	4	30	250	54.0	24.0	–	JB M20	250
JM W53/34	4	30	200	36.3	20.9	–	JB M20	200
JM W50/30	4	30	200	20.2	14.0	–	JB M20	200
JM W40/22	3	30	150	11.4	6.6	–	JC M16	150
JXM W64/44	5	40	250	53.3	17.4	37.8	JXE M24	250
JXM W53/34	4	30	200	43.3	13.1	30.8/26.6 ²⁾	JXB M20	200
JXM W41/27	4	30	200	25.0	6.2	16.8	JXH M16	200
JXM W38/23	4	30	200	18.0	5.9	16.8	JXH M16	200
JXM W29/20	3	30	150	10.9	2.0	11.2	JXD M12	150

¹⁾ For simultaneous loads in all load directions, it is recommended to check the ratio of the rated values of force and resistance.

If the load is applied at a distance from the channel lip, e.g. in the case of spaced mounting, the bolt bending moments must be taken into account and superimposed on the tensile load component. The bolt load capacity and the max. point load capacity must be observed. The lower value is decisive in each case.

For the full transverse tensile load capacity, the torques must be applied as a function of the bolt size and bolt quality in accordance with page 29, 52, 53 and 55.

²⁾ Value applies to stainless steel.

Profile overview: Cold-formed mounting channels

Mounting channels JM K¹⁾

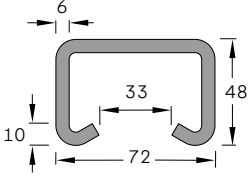
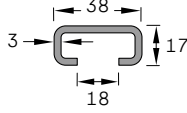
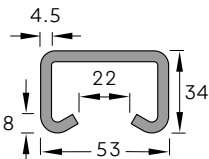
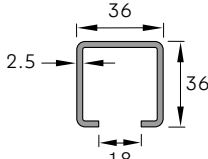
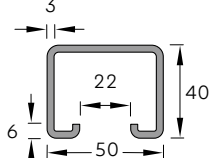
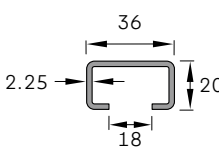
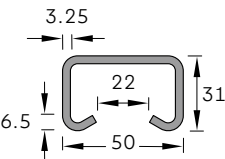
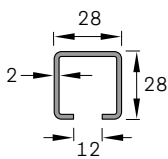
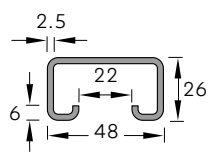
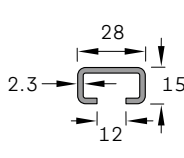
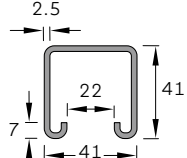
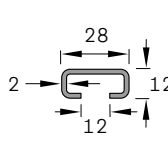
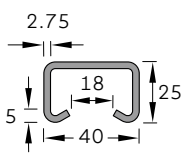
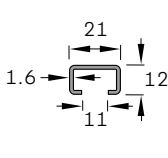
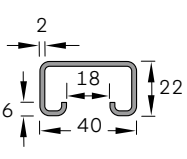
	<p>JM K 72/48</p> <p>wb, fv, A4 Bolt JAM20 - M30 Locking plate JGM A M20</p>		<p>JM K 38/17</p> <p>wb, fv, A4 Bolt JH M10 - M16 Locking plate JGM H M5 - M12</p>
	<p>JM K 53/34</p> <p>wb, fv, A4 Bolt JB M10 - M20 Locking plate JGM B M6 - M16</p>		<p>JM K 36/36</p> <p>wb, fv, A4 Bolt JH M10 - M16 Locking plate JGM H M5 - M12</p>
	<p>JM K 50/40</p> <p>wb, fv Bolt JBM10 - M20 Locking plate JGMBM6 - M16</p>		<p>JM K 36/20</p> <p>wb, fv Bolt JH M10 - M16 Locking plate JGM H M5 - M12</p>
	<p>JM K 50/30</p> <p>wb, fv, A4 Bolt JBM10 - M20 Locking plate JGMBM6 - M16</p>		<p>JM K 28/28</p> <p>wb, fv, A4 Bolt JD M6 - M12 Locking plate JGM D M4 - M10</p>
	<p>JM K 48/26</p> <p>wb, fv Bolt JBM10 - M20 Locking plate JGMBM6 - M16</p>		<p>JM K 28/15</p> <p>wb, fv, A4 Bolt JD M6 - M12 Locking plate JGM D M4 - M10</p>
	<p>JM K 41/41</p> <p>wb, fv Anchor nut JAM 22 M6 - M12 JAM 22 F M6 - M12</p>		<p>JM K 28/12</p> <p>wb, fv, A4 Bolt JD M6 - M10 Locking plate JGM D M4 - M10</p>
	<p>JM K 40/25</p> <p>wb, fv, A4 Bolt JC M10 - M16 Locking plate JGMC M6 - M16</p>		<p>JM K 21/12</p> <p>sv Bolt JG M6 - M8 Locking plate JGM G M4 - M8</p>
	<p>JM K 40/22</p> <p>wb, fv Bolt JC M10 - M16 Locking plate JGM C M6 - M16</p>	<p>Version and material</p> <ul style="list-style-type: none"> wb = Rolled, plain fv = Hot-dip galvanised sv = Sendzimir galvanised A4 = Stainless steel 1.4401/1.4404/1.4571 	

¹⁾ Profile dimensions subject to tolerances.

Perforated mounting channels (hole profiles) JML¹⁾

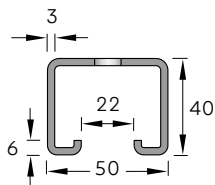

JML K 50/40

wb, fv – LL 11 × 40
 Bolt
 JB M10 – M20
 Locking plate
 JGM B M6 – M16

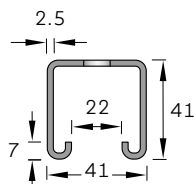

JML K 41/41

wb, fv – LL 11 × 40
 Anchor nut
 JAM 22 M6 – M12
 JAM 22 F M6 – M12

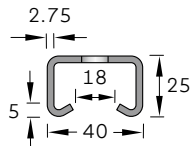

JML K 40/25

wb, fv, A4 – LL 11 × 40
 Bolt
 JC M10 – M16
 Locking plate
 JGM C M6 – M16

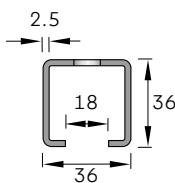

JML K 36/36

wb, fv, A4 – LL 11 × 40
 Bolt
 JH M10 – M16
 Locking plate
 JGM H M5 – M12

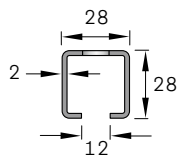

JML K 28/28

wb, fv, A4 – LL 11 × 40
 Bolt
 JD M6 – M12
 Locking plate
 JGM D M4 – M10

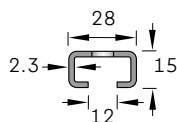

JML K 28/15

wb, fv, A4 – LL 9 × 25
 Bolt
 JD M 6-12
 Locking plate
 JGM D M 4-10

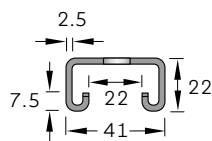

JZML K41/22

wb, fv, A4 – LL 11 × 40
 Toothed t-bolt
 JZS M12 – M16

Toothed mounting channels JZM¹⁾

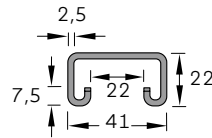

JZM K 41/22

wb, fv, A4
 Toothed t-bolts
 JZS M12 – M16



The toothed and cold-formed profiles of the JORDAHL® mounting channels can be used, among other things, for fastening pipes, cables, etc. by means of cable clamps.

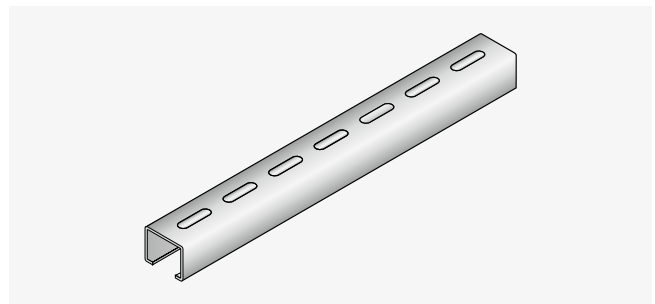

Perforated mounting channels

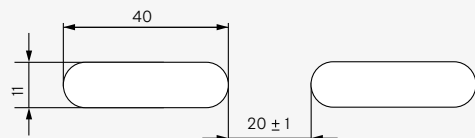

Standard hole pattern 11 x 40

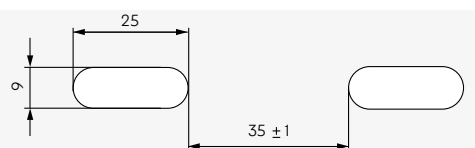

Standard hole pattern 9 x 25

Example order for JM perforated mounting channel

Type	Profile	Channel length mm	Version
JM	K 28/15 -	6,000	fv

Technical data

Weight, cross-section values, moments of inertia and resistance, point load capacity

$$\text{Perm. F} = \frac{F_{Rd}}{1.4}$$



	Weight ¹⁾	Cross-section	Centre of gravity	Moments of inertia		Moments of resistance			Max. rated resistance ^{2) 4)}
	G kg/m	A cm ²	e cm	I _y cm ⁴	I _z cm ⁴	W _y cm ³	W _z cm ³	W _{ply} cm ³	N _{Rd} kN
JM W72/48	8.84	11.27	2.40	34.97	83.27	14.57	23.13	18.28	66.1
JM W55/42	6.76	8.61	2.21	18.75	36.27	8.49	13.31	11.72	54.4
JM W53/34	4.98	6.34	1.74	9.33	23.70	5.35	9.03	7.18	36.7
JM W50/30	3.23	4.12	1.60	5.19	13.89	3.24	5.67	4.34	20.6
JM W40/22	2.10	2.68	1.22	1.97	5.87	1.62	2.97	2.15	11.7
JXM W64/44	7.19	9.16	2.29	24.12	54.20	10.52	16.94	13.80	53.3
JXM W53/34	4.64	5.91	1.85	9.25	23.19	5.01	8.83	6.86	43.3
JXM W 41/27	3.35	4.27	1.52	3.84	9.43	2.52	4.71	3.69	25.0
JXM W38/23	2.42	3.08	1.33	2.10	6.13	1.57	3.23	2.30	18.0
JXM W29/20	1.55	1.97	1.12	1.01	2.39	0.90	1.65	1.29	10.9
JM K 72/48	8.11	10.33	2.87	29.36	75.44	10.23	20.96	15.67	55.6
JM K 53/34	4.49	5.72	2.00	8.11	22.40	4.05	8.38	6.16	35.0
JM K 50/40	3.41	4.34	2.23	9.37	16.46	4.20	6.59	5.81	16.8
JM K 50/30	3.01	3.84	1.77	4.33	13.54	2.45	5.42	3.69	16.8
JM K 48/26	2.25	2.87	1.50	2.65	9.23	1.76	3.85	2.52	11.2
JM K 41/41	2.60	3.32	2.30	7.03	9.02	3.05	4.40	4.37	11.2
JZM K 41/22	1.87	2.39	1.34	1.51	5.72	1.12	2.79	1.72	7.0
JM K 40/25	2.09	2.66	1.48	2.06	6.09	1.39	3.05	2.11	11.2
JM K 40/22	1.53	1.95	1.26	1.29	4.34	1.02	2.17	1.46	7.0
JM K 38/17	1.81	2.30	1.05	0.86	4.29	0.82	2.26	1.24	9.8
JM K 36/36	2.22	2.83	2.07	4.61	6.09	2.23	3.34	3.24	4.9
JM K 36/20	1.46	1.85	1.19	0.98	3.51	0.82	1.92	1.20	4.9
JM K 28/28	1.39	1.77	1.58	1.77	2.20	1.12	1.57	1.59	4.9
JM K 28/15	1.11	1.42	0.89	0.41	1.47	0.46	1.05	0.68	4.9
JM K 28/12	0.89	1.13	0.71	0.21	1.12	0.29	0.80	0.43	4.9
JM K 21/12	0.58	0.74	0.72	0.13	0.46	0.18	0.44	0.28	3.5
JML K 50/40	3.15	4.01	2.10	8.44	16.41	4.02	6.56	5.29	16.8
JML K 41/41	2.39	3.04	2.15	6.19	9.00	2.87	4.39	3.91	11.2
JZML K 41/22	1.66	2.11	1.24	1.31	5.71	1.06	2.78	1.53	7.0
JML K 40/25	1.85	2.36	1.37	1.79	6.08	1.31	3.04	1.87	11.2
JML K 36/36	2.00	2.55	1.92	4.01	6.06	2.09	3.32	2.86	4.9
JML K 28/28	1.22	1.55	1.42	1.45	2.18	1.03	1.56	1.34	4.9
JML K 28/15	0.95	1.21	0.80	0.34	1.45	0.43	1.04	0.59	4.9

¹⁾ All weights per metre for rolled plain steel. For galvanised profiles, the following applies: Weight per meter × 1.10. For A4 profiles, the following applies: Weight per meter × 1.02.

²⁾ The bolt load capacity (see page 52, 53 and 55) must also be taken into account. The lower value is decisive in each case.

Bending load capacity^{2) 3) 4)} for span L

$$\text{Perm. F} = \frac{F_{Rd}}{1.4}$$

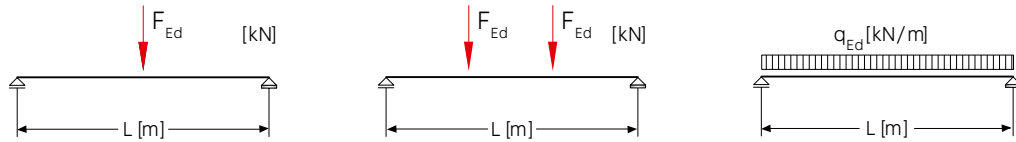

	F _{Rd} kN			F _{Rd} kN			q _{Rd} kN		
	L = 0.5 m	L = 1.0 m	L = 1.5 m	L = 0.5 m	L = 1.0 m	L = 1.5 m	L = 0.5 m	L = 1.0 m	L = 1.5 m
JM W72/48	34.4	17.2	11.5	25.8	12.9	8.6	137.5	34.4	15.3
JM W55/42	25.8	12.9	7.8	19.3	9.7	4.6	103.1	25.8	8.4
JM W53/34	13.5	6.7	3.9	10.1	5.1	2.3	54.0	13.5	4.2
JM W50/30	8.2	4.1	2.2	6.1	2.9	1.3	32.6	7.8	2.3
JM W40/22	4.0	1.9	0.8	3.0	1.1	0.5	16.2	3.0	0.9
JXM W64/44	35.1	17.6	10.1	26.3	13.2	5.9	140.5	35.1	10.8
JXM W53/34	17.5	8.7	3.9	13.1	5.1	2.3	69.8	13.9	4.1
JXM W 41/27	9.4	3.6	1.6	7.0	2.1	0.9	37.6	5.8	1.7
JXM W38/23	5.9	2.0	0.9	4.4	1.2	0.5	23.4	3.2	0.9
JXM W29/20	3.3	1.0	0.4	2.2	0.6	0.2	12.2	1.5	0.5
JM K72/48	31.3	15.7	10.4	23.5	11.8	7.2	125.3	31.3	13.1
JM K53/34	11.7	5.8	3.4	8.7	4.4	2.0	46.6	11.7	3.6
JM K50/40	9.9	5.0	3.4	7.4	3.8	2.3	39.8	9.9	4.2
JM K50/30	7.0	3.5	1.8	5.2	2.4	1.1	27.9	6.5	1.9
JM K48/26	4.3	2.2	1.1	3.2	1.5	0.7	17.2	4.0	1.2
JM K41/41	7.5	3.8	2.5	5.6	2.8	1.7	29.8	7.5	3.1
JZM K41/22	2.9	1.4	0.6	2.2	0.8	0.4	11.8	2.3	0.7
JM K40/25	4.0	1.9	0.9	3.0	1.1	0.5	16.0	3.1	0.9
JM K40/22	2.5	1.3	0.6	1.9	0.7	–	9.9	2.0	0.6
JM K38/17	2.3	0.8	–	1.8	0.5	–	9.3	1.3	0.4
JM K36/36	5.6	2.8	1.8	4.2	2.1	1.1	22.1	5.6	2.1
JM K36/20	2.1	0.9	0.4	1.5	0.6	–	8.2	1.5	0.4
JM K28/28	2.7	1.4	0.7	2.1	1.0	0.4	10.9	2.7	0.8
JM K28/15	1.2	0.4	–	0.9	–	–	4.7	0.6	–
JM K28/12	0.7	–	–	0.5	–	–	2.5	–	–
JM K21/12	0.5	–	–	–	–	–	1.6	–	–
JML K50/40	9.1	4.5	3.1	6.8	3.4	2.1	36.2	9.1	3.8
JML K41/41	6.7	3.4	2.2	5.0	2.5	1.5	26.7	6.7	2.8
JZML K41/22	2.7	1.3	0.6	2.0	0.7	–	10.5	2.0	0.6
JML K40/25	3.5	1.7	0.7	2.7	1.0	0.4	14.2	2.7	0.8
JML K36/36	4.9	2.4	1.7	3.7	1.8	1.0	19.6	4.9	1.8
JML K28/28	2.3	1.1	0.6	1.7	0.8	0.4	9.2	2.2	0.7
JML K28/15	1.0	–	–	0.8	–	–	4.0	0.5	–

³⁾ All load capacities were calculated elastically-plastically in acc. w/ EN 1993-1. Deflection limit l/150 at service/permissible load level.

If the application conditions are known exactly, the structural engineer must carry out verifications with partial safety factors.

For the practitioner we recommend an estimation with approx. 80% of the values given above.

⁴⁾ For mounting channels in stainless steel, a separate verification of deflection must be carried out, taking into account the applicable E-modulus.

Bolts



All JORDAHL® bolts are perfectly tailored to the channel range and guarantee secure fastening of attachment parts. For each channel type, the appropriate bolts including nuts are available for establishing a positive connection.

JORDAHL® hook-head t-bolts

Hook-head t-bolts are used for positive-locking connections in smooth hot-rolled and cold-formed channels. They enable JORDAHL® anchor channels JTA W, for example, to safely transmit loads from tensile and transverse directions. With European Technical Assessment **ETA-09/0338**.



JORDAHL® tee-head bolts

Tee-head bolts are best suited for smooth cold-formed JORDAHL® channels. Due to their smooth bolt head they form a positive connection e.g. with JORDAHL® anchor channels JTA K 38/17. With European Technical Assessment **ETA-09/0338**.



JORDAHL® toothed t-bolts

The bolt teeth fit perfectly into the toothed JORDAHL® channels. In combination with toothed t-bolts, the JORDAHL® toothed anchor channels JXA W can also bear loads in all directions. With European Technical Assessment **ETA-09/0338**.



JORDAHL® double-notch toothed t-bolts

The double-notch teeth press into the non-serrated JORDAHL® channels when the bolt is tightened, thereby creating a positive, slip-proof connection. As a result, force transmission is possible in all directions for hot-rolled channels under static load. With European Technical Assessment **ETA-09/0338**.



Determining the bolt length

Bolt	Sum m+s+u mm
M6	8.8
M8	11.3
M10	13.9
M12	17.3
M16	21.8
M20	27.0
M24	32.5
M27	35.8
M30	38.6

Min. l mm = $l_k + f + (m+s+u)$

Example

JORDAHL® anchor channel JTA K 53/34, $f = 8$ mm,
 prev. clamp length $l_k = 65$ mm
 JORDAHL® bolt JB M16 4.6 gv

Min. l = 65 + 8 + 21.8 = 94.8 mm → 100 mm

Selected: JB M16 × 100 4.6 gv

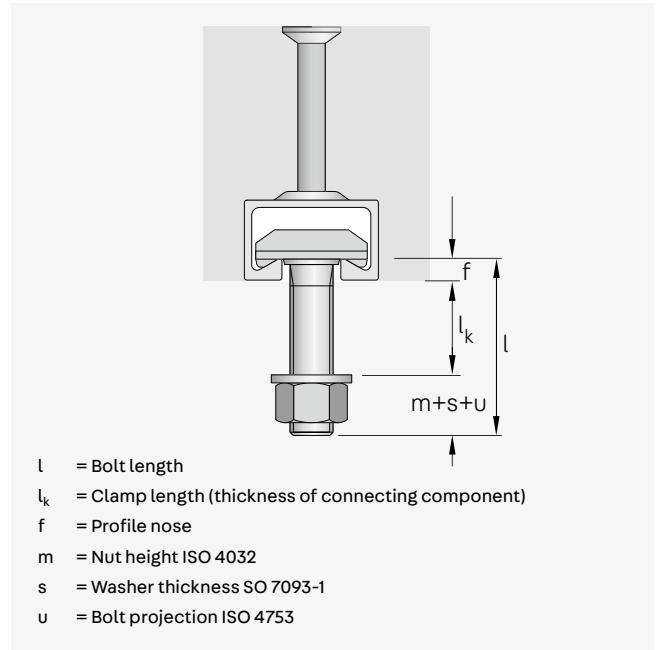

Bolts are supplied with nuts. Washers must be ordered separately (see "Bolt accessories" on page 60).

Profile noses f mm

Profile	f	Profile	f	Profile	f	Profile	f
W 72/48	15.5	K 72/48	10.0	XW 64/44	10.0	K 50/40	8.0
W 55/42	12.9	K 53/34	8.0	XW 53/34	7.5	K 48/26	6.0
W 53/34	10.5	K 50/30	6.5	XW 41/27	7.0	K 40/22	6.0
W 50+	8.0	K 40/25	5.0	XW 38/23	5.5	K 36/36	2.5
W 50/30	8.0	K 38/17	3.0	XW 29/20	5.0	K 36/20	2.3
W 40+	6.0	K 28/15	2.3	ZK 41/22	7.5	K 28/28	2.0
W 40/22	6.0	K 21/12	1.6			K 28/12	2.0

Position marking

Hook-head t-bolts and tee-head bolts are marked at the end of the shaft with **a notch (A)**.

Toothed t-bolts and notched bolts are marked with **two notches (B)** at the end of the shaft.

After assembly, the notch(es) must be perpendicular to the longitudinal direction of the channel!

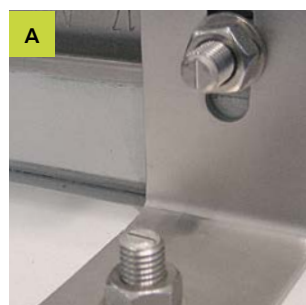

Hook-head t-bolt range

European Technical Assessment ETA-09/0338

Type JA

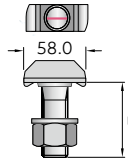

W 72/48, K 72/48

Length l mm	M20	M24	M27 M30
50	4.6 fv 8.8 fv	4.6 fv A4-50	—
60	8.8 fv	—	—
75	4.6 fv 8.8 fv	4.6 fv 8.8 fv	4.6 fv
100	4.6 fv 8.8 fv 4.6 gv	4.6 fv 8.8 fv A4-50	4.6 fv
125	8.8 fv	—	—
150	4.6 fv 8.8 fv 4.6 gv	8.8 fv 4.6 gv A4-50 FA-70	4.6 gv ¹⁾
200	4.6 fv	4.6 fv 8.8 fv	4.6 fv ¹⁾

Type JB⁴⁾

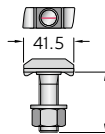

W 55/42, W 53/34, W 50+, W 50/30,
K 53/34, K 50/30, K 50/40, K 48/26³⁾

Length l mm	M10	M12	M16	Length l mm	M20	M24 ²⁾
30	4.6 gv A4-50	4.6 fv 4.6 gv A4-50	4.6 gv A4-50	35	4.6 gv 8.8 gv A4-50	—
40	4.6 gv	4.6 fv 8.8 fv 4.6 gv A4-50 FA-70	4.6 fv 8.8 fv 4.6 gv A4-50	45	4.6 fv 4.6 gv 8.8 gv A4-50	—
50	4.6 gv	4.6 fv 8.8 fv 4.6 gv A4-50 FA-70	4.6 fv 8.8 fv 8.8 gv A4-50 FA-70	55	4.6 fv 8.8 fv 4.6 gv A4-50 FA-70	—
60	4.6 fv 8.8 fv 4.6 gv	4.6 fv 8.8 fv 4.6 gv A4-50 FA-70	A4-50	60	—	4.6 gv
65	4.6 fv 8.8 fv 4.6 gv 8.8 gv	—	—	65	A4-50	—
80	4.6 gv	4.6 fv 8.8 fv 4.6 gv A4-50	4.6 fv 8.8 fv 8.8 gv A4-50 FA-70	75	4.6 fv 8.8 fv 4.6 gv A4-50 FA-70	4.6 fv 4.6 gv
100	4.6 gv	4.6 fv 8.8 fv 4.6 gv A4-50 FA-70	4.6 fv 8.8 fv 8.8 gv A4-50	80	FA-70	—
125	—	4.6 fv 4.6 gv 8.8 gv A4-50	8.8 fv 4.6 gv 8.8 gv A4-50	100	4.6 fv 8.8 fv 4.6 gv 8.8 gv A4-50 FA-70	4.6 fv
150	—	4.6 gv	4.6 fv 4.6 gv A4-50	125	4.6 fv 8.8 fv 4.6 gv 8.8 gv A4-50	—
200	—	8.8 fv 4.6 gv	4.6 fv A4-50	150	4.6 fv 8.8 fv 4.6 gv 8.8 gv A4-50 FA-70	8.8 gv
300	—	4.6 gv	4.6 gv	200	4.6 fv 4.6 gv	—
				300	4.6 gv	—

Type JC⁴⁾

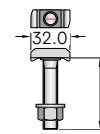

W 40+, W 40/22,
K 40/22, K 40/25

Length l mm	M10	M12	M16
30	4.6 gv A4-50	4.6 gv A4-50	4.6 gv A4-50
40	4.6 fv 4.6 gv A4-50	4.6 fv 8.8 fv 4.6 gv A4-50 FA-70	4.6 fv 8.8 fv 4.6 gv 8.8 gv A4-50 FA-70
50	4.6 gv A4-50	4.6 fv 8.8 fv 4.6 gv A4-50 FA-70	4.6 fv 8.8 fv 4.6 gv 8.8 gv A4-50 FA-70
60	4.6 fv 4.6 gv A4-50	4.6 fv 8.8 fv 4.6 gv A4-50	4.6 fv 8.8 fv 4.6 gv 8.8 gv A4-50 FA-70
80	4.6 fv 4.6 gv	4.6 fv 8.8 fv 4.6 gv A4-50	4.6 fv 8.8 fv 4.6 gv 8.8 gv A4-50 FA-70
100	4.6 fv 4.6 gv	4.6 fv 8.8 fv 4.6 gv A4-50 FA-70	4.6 fv 8.8 fv 4.6 gv 8.8 gv A4-50 FA-70
125	—	8.8 fv 4.6 gv 8.8 gv	8.8 fv 4.6 gv 8.8 gv
150	—	8.8 fv 4.6 gv 8.8 gv A4-50	8.8 fv 4.6 gv 8.8 gv A4-50
200	—	8.8 fv 4.6 gv 8.8 gv	8.8 fv 4.6 gv A4-50
250	—	—	4.6 gv
300	—	—	4.6 gv

¹⁾ Not available as JA M27. ²⁾ JB M24 only for profile W55/42. ³⁾ K 48/26 - M20 8.8 cannot be used. ⁴⁾ Head shape is square or drawn at an angle.

Tee-head bolt range

European Technical Assessment ETA-09/0338

Type JH

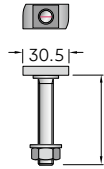

K 38/17, K 36/36, K 36/20

Length l mm	M10	M12	M16
20	4.6 fv 4.6 gv	4.6 gv	4.6 gv
25	—	4.6 gv A4-50 A4-70	A4-50
30	4.6 fv 4.6 gv A4-50 A4-70	4.6 fv 8.8 fv 4.6 gv 8.8 gv A4-50 A4-70	8.8 fv 4.6 gv 8.8 gv A4-50
40	4.6 gv A4-50 A4-70	4.6 fv 4.6 gv A4-50 A4-70	4.6 fv 4.6 gv A4-50
50	4.6 fv 4.6 gv A4-50 A4-70	4.6 fv 4.6 gv A4-50 A4-70	4.6 fv 4.6 gv A4-50
60	4.6 fv 4.6 gv A4-50 A4-70	4.6 fv 4.6 gv A4-50 A4-70	4.6 fv 8.8 fv 4.6 gv A4-50
80	4.6 fv 4.6 gv	4.6 fv 4.6 gv A4-50	4.6 fv 4.6 gv A4-50
100	4.6 gv	4.6 fv 8.8 fv 4.6 gv A4-50 A4-70	4.6 fv 4.6 gv A4-50 A4-70
125	4.6 gv	4.6 gv 8.8 gv	4.6 gv
150	4.6 gv	4.6 gv 8.8 gv A4-50	4.6 gv 8.8 gv A4-50
200	—	4.6 gv 8.8 gv A4-50	A4-50

Type JD

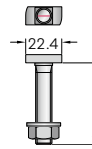

K 28/28, K 28/15, K 28/12 K 28/28,
K 28/15

Length l mm	M6	M8	M10	M12
15	4.6 gv	4.6 gv	4.6 gv	4.6 gv
20	4.6 gv	4.6 gv	4.6 gv	—
25	4.6 gv	4.6 gv	4.6 gv A4-50 A4-70	—
30	4.6 gv	4.6 gv A4-50 A4-70	4.6 fv 4.6 gv A4-50 A4-70	4.6 gv
40	4.6 gv	4.6 gv	4.6 fv 4.6 gv A4-50 A4-70	4.6 gv
50	4.6 gv	4.6 gv	4.6 gv A4-50 A4-70	4.6 fv 4.6 gv
60	4.6 gv	4.6 gv	4.6 fv 4.6 gv A4-50 A4-70	4.6 fv
80	—	4.6 fv 4.6 gv	4.6 gv A4-50	4.6 fv 4.6 gv
100	—	4.6 fv 4.6 gv	4.6 fv 4.6 gv A4-50 A4-70	—
125	—	4.6 gv	4.6 gv A4-50	—
150	—	4.6 gv	4.6 gv A4-50	—
200	—	—	4.6 gv	—

Type JG

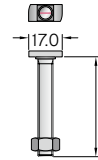

K 21/12

Length l mm	M6	M8
15	4.6 gv	4.6 gv
20	4.6 gv	4.6 gv
25	—	4.6 gv
30	4.6 gv	4.6 gv A4-50
40	4.6 gv	4.6 gv A4-50
50	4.6 gv	4.6 gv A4-50
60	4.6 gv	4.6 gv
80	—	4.6 gv
100	—	4.6 gv

Version and material of bolts

- **fv** Hot-dip galvanised steel, strength class 4.6
- **fv** Hot-dip galvanised steel, strength class 8.8
- **gv** Electrogalvanised steel, strength class 4.6
- **gv** Electrogalvanised steel, strength class 8.8
- **A4-50** Stainless steel
- **A4-70** Stainless steel
- **FA-70** Stainless steel (ΔF4-70)

Example order for JORDAHL® bolts

Type	Thread Ø	Length mm	Strength class	Version
JB	M16	× 100	4.6	gv

Rated values for steel bolts

Rated resistance values

		M6	M8	M10	M12	M16	M20	M24	M27	M30
Channel profile	JTA-CE									
	K 28/15	Tee-head bolt type JD				–	–	–	–	–
	K 38/17	–	–	Tee-head bolt type JH			–	–	–	–
	W 40+ W 40/22 K 40/25	–	–	Hook-head t-bolt type JC			–	–	–	–
	W 50+ W 50/30 K 50/30	–	–	Hook-head t-bolt type JB			–	–	–	–
	W 53/34 K 53/34	–	–	Hook-head t-bolt type JB			–	–	–	–
	W 55/42	–	–	Hook-head t-bolt type JB/JE			–	–	–	–
W 72/48 K 72/48	–	–	–	–	–	Hook-head t-bolt type JA				
Bolt load capacity	4.6									
	Tensile force N_{Rd} kN	4.0	7.3	11.6	16.9	31.4	49.0	70.6	91.8	112.2
	Shear force V_{Rd} kN	2.9	5.3	8.3	12.1	22.6	35.2	50.7	66.0	80.6
	8.8									
Tensile force N_{Rd} kN	–	19.5	30.9	44.9	83.7	130.7	188.3	–	–	
Shear force V_{Rd} kN	–	11.7	18.6	27.0	50.2	78.4	113.0	–	–	

JORDAHL® bolts are available in electrogalvanised (gv) and hot-dip galvanised versions.

Rated bending moments

		M6	M8	M10	M12	M16	M20	M24	M27	M30
Through hole in attachment part mm		7	9	12	14	18	22	26	30	33
Rated bending moment $M_{Rd,s}$ Nm	4.6	3.8	9.0	17.9	31.4	79.8	155.4	268.9	398.7	538.7
	8.8	9.8	24.0	47.8	83.8	213.1	415.4	718.4	1065.2	1439.4

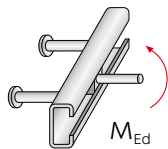

Spaced mounting

With spaced mounting, a connection is subjected to a bending moment as well as to tensile and shear forces. The above rated bending moments are to be taken into account. The matching washer can be found on page 60.



Notes

The bolt load capacity may be limited by the channel load capacity. The lower value is decisive.

Rated values for stainless steel bolts

Rated resistance values

		M8	M10	M12	M16	M20	M24	
Channel profile	K 28/15	Tee-head bolt type JD		–	–	–	–	
	K 38/17	–	Tee-head bolt type JH			–	–	
	JTA-CE	W 40/22 K 40/25	–	Hook-head t-bolt type JC			–	–
		W 50/30 K 50/30	–	Hook-head t-bolt type JB			–	–
	W 53/34 K 53/34	–	Hook-head t-bolt type JB			–	–	
	W 72/48 K 72/48	–	–	–	–	–	Hook-head t-bolt type JA	
Bolt load capacity	A4-50	Tensile force N_{Rd} kN	–	10.1	14.8	27.4	42.8	61.7
		Shear force V_{Rd} kN	–	7.3	10.6	19.8	30.9	44.5
	FA-70	Tensile force N_{Rd} kN	13.7	21.7	31.6	58.8	91.7	–
		Shear force V_{Rd} kN	9.9	15.6	22.7	42.2	66.0	–

JORDAHL® stainless steel bolts are preferably made of stainless steel of corrosivity categories C4 (A4, L4) and C5 (FA, HC).

Rated bending moments

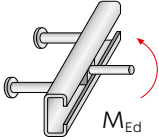
		M8	M10	M12	M16	M20	M24	M27	M30	
Through hole in attachment part mm		9	12	14	18	22	26	30	33	
Rated bending moment $M_{Rd,s}$ Nm		A4-50	7.9	15.7	27.5	70.0	136.3	235.8	–	–
		A4-70 FA-70	16.8	33.5	58.8	149.4	291.3	503.7	–	–

JORDAHL® hook-head t-bolts with different surface qualities



gv



fv



A4



Notes

JORDAHL® bolts: electrogalvanised (gv), hot-dip galvanised (fv), stainless steel (A4), select bolts according to corrosion protection requirements.

Toothed and double-notch toothed t-bolts range

European Technical Assessment ETA-09/0338

Toothed t-bolts

JXA W 64/44			JXA W 53/34			JXA W 38/23			JXA W 29/20			JZA K 41/22		
Type JXE			Type JXB			Type JXH			Type JXD			Type JZS		
Length l mm	M20	M24	Length l mm	M16	M20	Length l mm	M12	M16	Length l mm	M10	M12	Length l mm	M12	M16
50	FA-70	FA-70	60	8.8 fv FA-70	8.8 fv	30	8.8 fv	8.8 fv	30	-	8.8 fv	35	8.8 fv A4-50	A4-50
60	8.8 fv	-	65	-	8.8 fv	40	8.8 fv FA-70	8.8 fv	40	8.8 fv	8.8 fv FA-70	50	8.8 fv A4-50	8.8 fv A4-50
75	-	8.8 fv	80	8.8 fv FA-70	8.8 fv FA-70	50	8.8 fv	8.8 fv	50	-	8.8 fv	80	8.8 fv A4-50	8.8 fv A4-50
100	8.8 fv FA-70	8.8 fv FA-70	100	8.8 fv FA-70	8.8 fv FA-70	60	8.8 fv FA-70	8.8 fv FA-70	60	-	8.8 fv FA-70	100	-	8.8 fv A4-50
150	8.8 fv	8.8 fv	150	-	8.8 fv FA-70	80	8.8 fv FA-70	8.8 fv	80	-	8.8 fv FA-70	-	-	-
-	-	-	-	-	-	100	-	-	-	-	-	-	-	-
-	-	-	-	-	-	125	-	8.8 fv	125	-	8.8 fv	-	-	-
-	-	-	-	-	-	150	-	8.8 fv	150	-	8.8 fv	-	-	-
-	-	-	-	-	-	200	-	8.8 fv	-	-	-	-	-	-

Double-notch toothed t-bolts

JTA W 50+, JTA W 50/30, JTA W 53/34			JTA W 40+, JTA W 40/22	
Type JKB			Type JKC	
Length l mm	M16	M20	Length l mm	M16
40	8.8 fv	8.8 fv	40	8.8 fv
60	8.8 fv	8.8 fv	60	8.8 fv
80	8.8 fv	8.8 fv	80	8.8 fv
100	8.8 fv			



JORDAHL®
JKB double-notch toothed t-bolt



Notched teeth of the bolt press into the channel lip

Toothed t-bolts

Rated resistance values

		M10	M12	M16	M20	M24	
Channels	JXA, JXA-PC	W 29/20	JXD toothed t-bolt	–	–	–	
		W 38/23	–	JXH toothed t-bolt	–	–	
		W 53/34	–	–	JXB toothed t-bolt	–	
		W 64/44	–	–	–	JXE toothed t-bolt	
	JZA	K 41/22	–	JZS toothed t-bolt	–	–	
Bolt load capacity	8.8	F _{Rd} kN	18.6	27.0	50.2	78.4	113.0
	A4-50	F _{Rd} kN	–	10.6	19.8	–	–
	A4-70	F _{Rd} kN	15.6	22.7	42.2	66.0	95.1

$$\sqrt{N_{Ed}^2 + V_{y,Ed}^2 + V_{x,Ed}^2} \leq F_{Rd}$$



JORDAHL® JXB toothed t-bolt

Rated bending moments

		M10	M12	M16	M20	M24
Through hole in attachment part mm		12	14	18	22	26
Rated bending moment M _{Rd} Nm	8.8	47.8	83.8	213.1	415.4	718.4
	A4-50	–	27.5	70.0	–	–
	A4-70	33.5	58.8	149.4	291.3	503.7

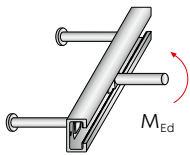

Double-notch toothed t-bolts

Rated resistance

JORDAHL® notch toothed anchor bolts are slip-resistant thanks to the double notch teeth. Longitudinal tensile forces V_{x,Ed} in the longitudinal direction of the channel of up to 10.5 kN can be transmitted with a safety factor of 3. The insert is intended for hot-dip galvanised JTA W hot-rolled profiles. The corrosion protection of the hot-dip galvanizing remains fully intact after installation.

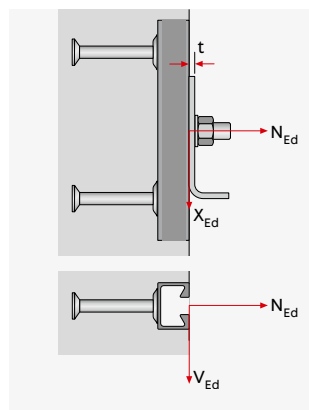

$$\sqrt{N_{Ed}^2 + V_{y,Ed}^2 + V_{x,Ed}^2} \leq F_{Rd}$$

$$\text{Perm. } F = \frac{F_{Rd}}{1.4}$$

Type	For JTA profiles	Recomm. tightening torque M _A	Min. attachment part thickness t	Longitudinal tension ¹⁾ V _{x,Rd} γ = 3.0 V _{x,Ed} ≤ V _{x,Rd}
8.8 fv	fv, wb	Nm	mm	kN
JKB M16	W 50/30 W 53/34	180	6	7.0
JKB M20	W 50/30 W 53/34	360	8	10.5
JKC M16	W 40/22	180	6	7.0

¹⁾ For simultaneous loads in multiple directions, the resultant load must not exceed the rated loads of the anchor channels in accordance with ETA-09/0338.

Pretensioned bolt connection

Pretensioning forces of bolts

In fastening technology, the bolt connections must be pretensioned for direct suspension and spaced mounting or when there are forces in the longitudinal direction of the channel in order to prevent unintentional loosening or slippage of the bolt connections. Higher-strength bolts (8.8) are not necessarily required for this application. Bolts of strength classes 4.6 and A4-50 are also suitable, provided the following points are taken into account:

- The force applied by the tightening torque is briefly greater than the externally acting load.
- Up to 30% of the applied pretensioning force is dissipated via relaxation.
- Stainless steel bolts have a higher coefficient of friction than electrogalvanised or hot-dip galvanised bolts. Therefore, the pretensioning forces are lower with stainless steel bolts.

- JORDAHL® bolts are delivered ready for installation. Before tightening, these bolts should not be additionally oiled or treated with lubricants.
- Pretensioned bolted connections may only be tensioned when steel is in contact with steel.
- If the channel is behind the concrete surface, the distance must be compensated for using a suitable washer (page 29 and 60). If this is not done, the installed component will be pretensioned against the concrete surface and stress will be induced in the concrete. This may cause cracking and splitting, and the anchor channel may be damaged.

Suspended direct and spaced mounting

Both cold-formed and hot-rolled profiles can be used in these applications. For pretensioning a bolted connection with galvanised bolts or stainless steel bolts, we recommend using the tightening torques.

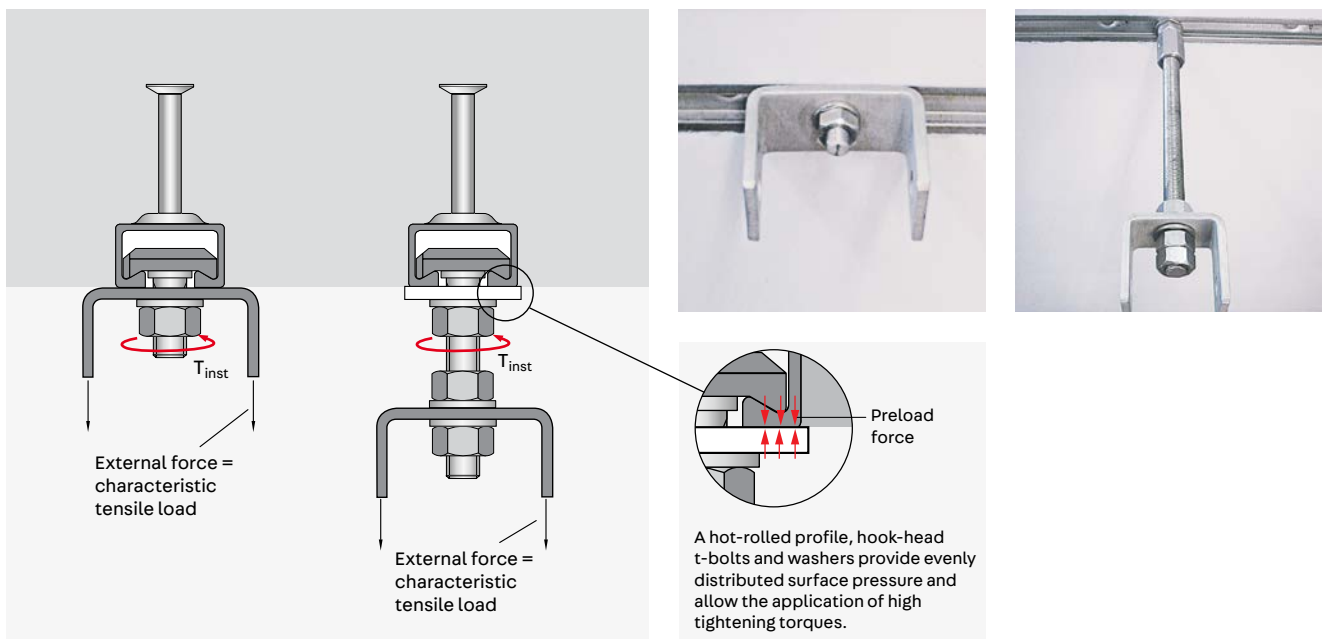

Relationship between pretensioned bolts and tightening torque

The correlation between bolt pretensioning force and tightening torque is shown in the following diagrams. The pretensioning forces vary strongly depending on the friction between nut and bolt. Low friction results in higher pretension, which is typical for hot-dip galvanised bolts with greased nuts (low).

Friction increases for electrogalvanised nuts and bolts (medium) and for stainless steel nuts and bolts (high). The tightening torque recommended for assembly can be increased by 30% without reaching the yield point of the bolts.

Bolt strength class 4.6 and stainless steel bolts A4-50

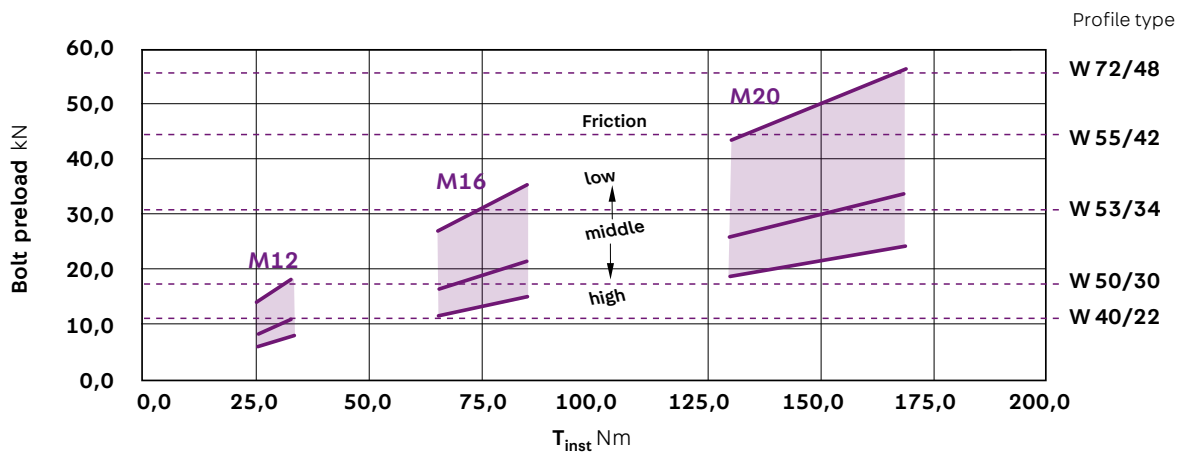

Bolt strength class 8.8 and stainless steel bolts A4-70 and FA-70

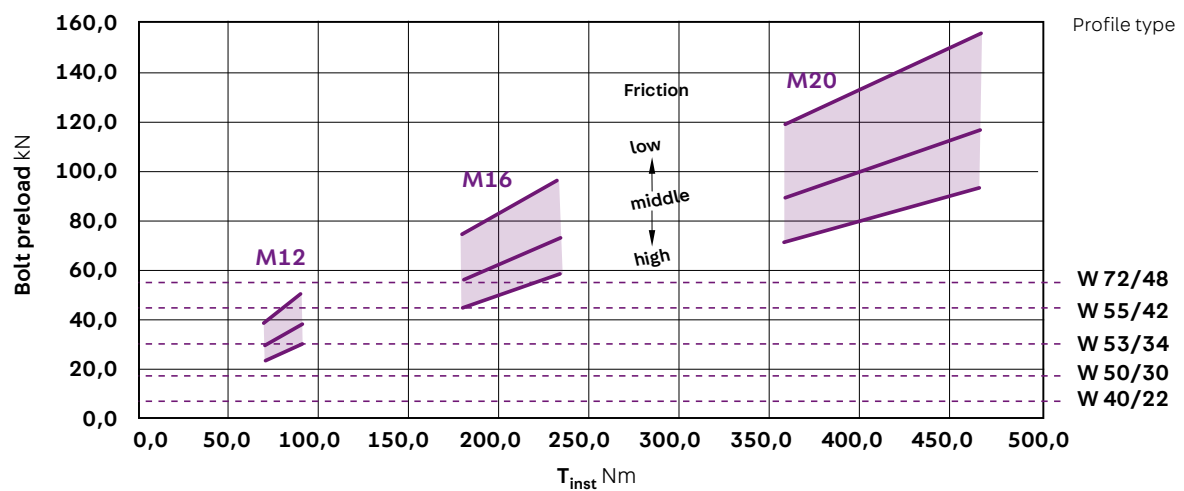

Information

For tightening torques and information on spaced mounting, please refer to page 29 (Installation of anchor channel).

Loads on bolts in longitudinal direction of channel

$$F_{Rd} = \text{Perm. } F \times 1.4$$

This application scenario has been verified by internal tests and is not part of the technical approval. The load that can be borne depends on the anchor channel material, the bolt used, or the bolt strength class and the tightening torque.

The safety against slippage at the specified tightening torques is approximately $\gamma = 5.0$. The specified loads in the longitudinal direction of the channel can be safely borne in combination with hot-rolled profiles and bolts of strength class 8.8 and FA-70. For structures with higher loads in the longitudinal direction of the channel, JORDAHL® toothed channels JXA and JZA should be used.

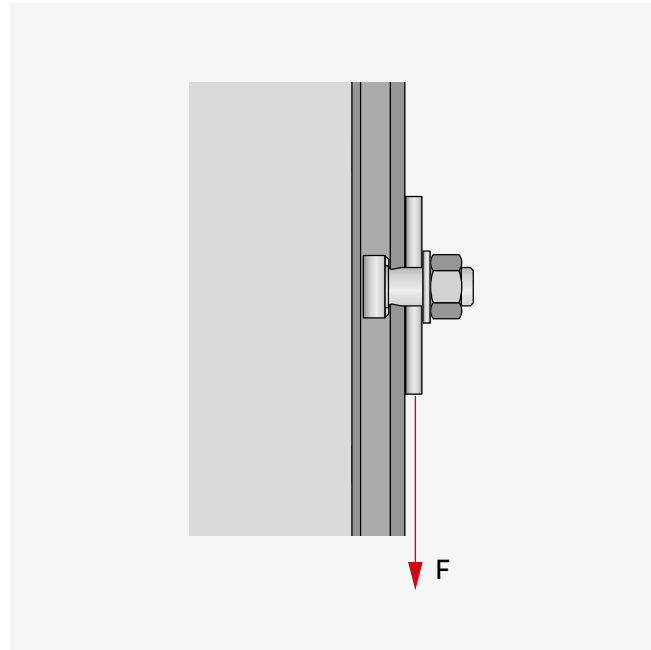

Recommended load capacity of anchor channels JTA parallel to the channel axis

JTA profile	Type	Bolts Ø	Tightening torques MA Nm	Recomm. load capacity in longitudinal direction of channel max. F kN		Minimum thickness of attachment parts mm
				Profile Steel, hot-dip galvanised	Profile Stainless steel, degreased	
				Bolts 8.8	Bolts FA-70	
W 72/48	JA	M24	620	4.2	1.96	10
		M20	360	2.9	1.36	10
W 55/42	JB	M24	620	4.2	1.96	10
		M20	360	2.9	1.36	10
		M16	180	1.9	0.85	10
W 53/34	JB	M20	360	2.9	1.36	6
		M16	180	1.9	0.85	6
W 50+ W 50/30	JB	M20	360	2.9	1.36	6
		M16	180	1.9	0.85	6
		M12	70	0.9	0.44	6
W 40+ W 40/22	JC	M16	180	1.9	0.85	5
		M12	70	0.9	0.44	5

Accessories



JORDAHL® accessories offer numerous products to meet the most diverse fastening requirements. Made of high-quality material, they are perfectly tailored for use with JORDAHL® channels and bolts.



JORDAHL® hook-head locking plates JGM



JORDAHL® hammer-head locking plates JGM



Clamping plates



JORDAHL® clamp connections JSV



Eye sockets/sleeve dowels



JORDAHL® connection straps JVB-ZS



JORDAHL® connection straps JVB-V



JORDAHL® connection straps JVB-N

Bolt accessories

Washers

Washers	Dimensions	d mm	D mm	s mm	Version
DIN EN ISO 7093-1, DIN 9021	6	6.4	18.0	1.6	fv, gv, A4
	8	8.4	24.0	2.0	fv, gv, A4
	10	10.5	30.0	2.5	fv, gv, A4
	12	13.0	37.0	3.0	fv, gv, A4
	16	17.0	50.0	3.0	fv, gv, A4
	20	21.0	60.0	4.0	fv, gv, A4
DIN EN ISO 7089, without chamfer, 200 HV ¹⁾ Acc. to DIN 125, 140 HV ²⁾	6 ¹⁾	6.4	12.0	1.6	fv, gv, A4
	8 ¹⁾	8.4	16.0	1.6	fv, gv, A4
	10	10.5	20.0	2.0	fv, gv, A4
	12	13.0	24.0	2.5	fv, gv, A4
	16	17.0	30.0	3.0	fv, gv, A4
	20	21.0	37.0	3.0	fv, gv, A4
	24	25.0	44.0	4.0	fv, gv, A4
	27	28.0	50.0	4.0	fv, gv, A4
	30	31.0	56.0	4.0	fv, gv, A4

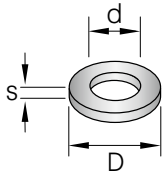
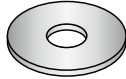

¹⁾ 140 HV; ²⁾ Vickers hardness

Square bearing plate for steel-steel contact

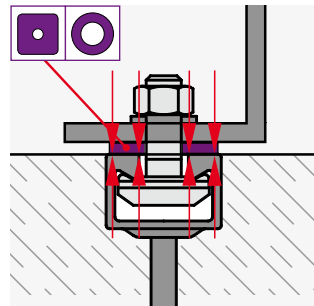
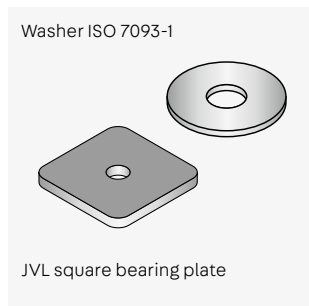

Example order for JORDAHL® square bearing plates

Type	Width	Thickness	Ø	Version
JVL	50	06	- 12	A4

Profile	Bolt / type	M8	M10	M12	M16	M20	M24	M27	M30
JTA K 28/15	JD	ISO 7093-1	ISO	ISO 7089	-	-	-	-	-
JXA W 29/20	JXD	-	7093-1	ISO 7093-1	-	-	-	-	-
JTA K 38/17	JH	-	JVL	ISO 7093-1 or	ISO 7093-1	-	-	-	-
JTA W 40/22 ²⁾	JC	-	3805-10	JVL 805-12	JVL 805-16	-	-	-	-
JTA K 40/25	JC	-	-	JVL	JVL	-	-	-	-
JZA K 41/22	JZS	-	-	3805-12	3805-16	-	-	-	-
JXA W 38/23	JXH	-	-	-	-	-	-	-	-
JTA W 50/30 ³⁾	JB	-	JVL	JVL	JVL	-	-	-	-
JTA K 50/30	JB	-	5006-10	5006-12	5006-16	-	-	-	-
JTA W 53/34	JB	-	-	-	JVL	-	-	-	-
JTA K 53/34	JB	-	-	-	5006-20	-	-	-	-
JXA W 53/34	JXB	-	-	-	-	-	-	-	-
JTA W 55/42	JB	-	-	-	-	JVL	-	-	-
JXA W 53/34	JXB	-	-	-	-	5006-24	-	-	-
JTA W 72/48	JA	-	-	-	-	JVL	JVL	JVL	JVL
JTA K 72/48	JA	-	-	-	-	7008-20	7008-24	7008-27	7008-30

²⁾ Also applies to JTA W 40+. ³⁾ Also applies to JTA W 50+.

Toothed washers

JORDAHL® toothed washers ensure slip-resistant bolt connections in slotted holes. Two notched teeth on the underside of the washer enable a positive-locked connection up to $V_{Ed} = 7.5$ kN with a safety factor of 3, which simultaneously offers the advantage of tolerance compensation in the slotted hole.

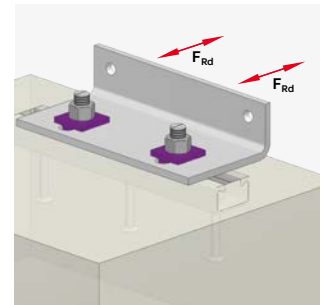

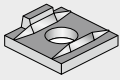
Toothed washer	Type and version	Geometry l x b x h mm	For bolt	F_{Rd} kN	Tightening torque Nm	Attachment part	
						Min. thickness mm	Yield strength N/mm ²
	JKZS 16 fv	40 x 40 x 6	M16 8.8	7.5	200	8	≤ 235

Spring washers (acc. to former DIN 127)

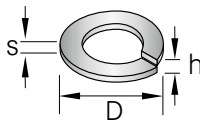
	Dimensions	h_{min} mm	D_{max} mm	s mm	Version
	B 6		3.6	11.8	1.6
B 8		4.6	14.8	2.0	gv, A4
B 10		5.0	18.1	2.2	gv, A4
B 12		5.8	21.1	2.5	gv, A4
B 16		7.8	27.4	3.5	gv, A4
B 20		8.8	33.6	4.0	gv, A4
B 24		11.0	40.0	5.0	gv, A4
B 30		13.6	48.2	6.0	gv, A4

Locknuts

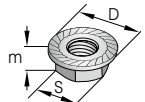
	Thread	D mm	m mm	s mm	t mm	Version
	M12		26.0	12	18	2.3
M16		34.5	16	24	2.1	gv (strength class 8)

Hexagon nuts (DIN EN ISO 4032, DIN 934)¹⁾

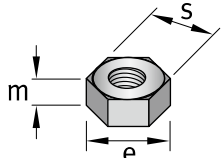
	Thread	e mm	s mm	m mm	Version
	M6		11.05	10.0	5.2
M8		14.38	13.0	6.8	A4, gv (strength class 8)
M10		18.90	16.0	8.4	A4, gv (strength class 8)
M12		21.10	18.0	10.8	A4, gv (strength class 8)
M16		26.75	24.0	14.8	A4, gv (strength class 8)
M20		32.95	30.0	18.0	A4, gv (strength class 8)
M24		39.55	36.0	21.5	A4, gv (strength class 8)
M27		45.20	41.0	23.8	A4, gv (strength class 8)
M30		50.85	46.0	25.6	A4, gv (strength class 8)

¹⁾ For alternating loads, we recommend self-locking nuts.

DIN 582 ring nuts

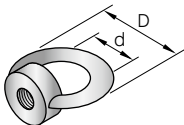
	Thread	d mm	D mm	F _{Rd} kN ¹⁾	Version
	M8	20.0	36.0	2.0	unfinished, gv
	M10	25.0	45.0	3.2	unfinished, gv
	M12	30.0	54.0	4.8	unfinished, gv
	M16	35.0	63.0	9.8	unfinished, gv
	M20	40.0	72.0	16.8	unfinished, gv
	M24	50.0	90.0	25.2	unfinished, gv

¹⁾ Load via centric tension.

Connection straps JVB

JORDAHL® connection straps JVB-Z, -ZS, -N and -V, in conjunction with JORDAHL® anchor channels JTA, provide a load-bearing fastening solution for prefabricated concrete parts. Due to the interlocking of the connection straps, the

necessary construction tolerances can be compensated for and the prefabricated elements can be optimally aligned in three dimensions. High tensile and/or transverse tensile loads can be transmitted.

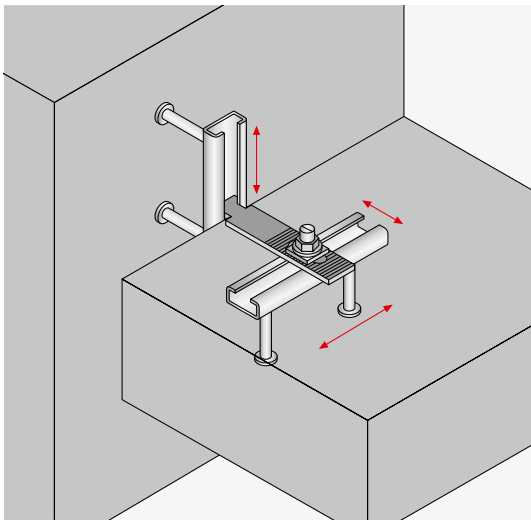

JORDAHL® connection strap JVB-Z for three-dimensional alignment

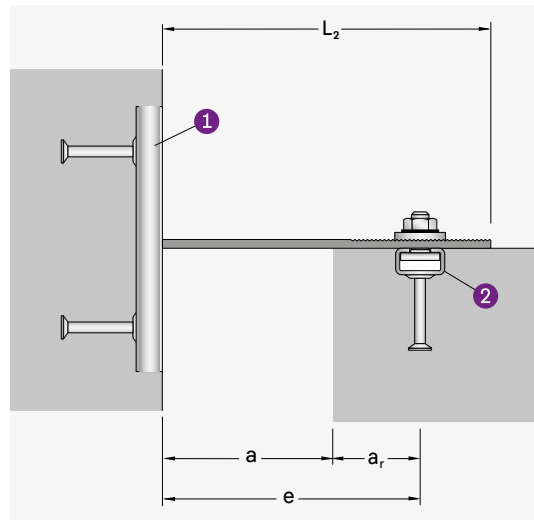

JVB-Z installation overview

JORDAHL® connection straps are available in four versions:

- JVB-Z for connections that are only subjected to tension forces, which allows for adjustment (tolerance compensation) of ± 20 mm.
- JVB-N for connections that are only subjected to tension forces, with allows for adjustment of up to ± 38 mm.
- JVB-ZS with welded JORDAHL® bolt for transmission of tensile and compressive forces, which allows for adjustment of ± 20 mm
- JVB-V for connections for the transmission of transverse loads, e.g. connection of prefabricated concrete elements.

The arrangement with a vertical and a horizontal JORDAHL® anchor channel allows for exact, three-dimensional alignment of the fastening.

Scope of delivery

JORDAHL® connection straps consist of:

- Type JVB-Z (toothed) with serrated plate
- Type JVB-ZS (toothed) with serrated plate, bolt, washer and nut, welded and pre-mounted
- Type JVB-V (toothed holes) with two eccentric inserts
- Type JVB-N (toothed slotted hole) with toothed locking plate

Material

- Electrogalvanised steel (gv)
- Stainless steel (A4, L4)

JVB-Z (for longitudinal tensile loads) and JVB-ZS (longitudinal tensile and compressive loads)

N_{Rd} kN	Type JVB-Z	Type JVB-ZS	Area of application			Dimensions mm			Fastening of anchor channel (1+2) Bolt ¹⁾
			Centre spacing $e \pm 20$ mm	Wall spacing a mm	Edge clearance a_r mm	Length L_1 for JVB-Z (JVB-ZS) mm	Length L_2 mm	Slotted hole LL	
4.9	JVB- 90-Z/12	–	50	0-20	50	10 (7)	90	11 × 55	JTA K 28/15 JD M10 × 30
	JVB-115-Z/12	JVB-115-ZS/12	75	5-45	50	10 (7)	115		
	JVB-140-Z/12	JVB-140-ZS/12	100	30-70	50	10 (7)	140		
	JVB-165-Z/12	JVB-165-ZS/12	125	55-95	50	10 (7)	165		
	JVB-190-Z/12	JVB-190-ZS/12	150	80-120	50	10 (7)	190		
	JVB-215-Z/12	JVB-215-ZS/12	175	105-145	50	10 (7)	215		
	JVB-240-Z/12	–	200	130-170	50	10 (7)	240		
9.8	JVB-115-Z/18	–	75	0-20	75	12 (10)	115	13 × 55	JTA K 38/17 JH M12 × 40
	JVB-140-Z/18	JVB-140-ZS/18	100	5-45	75	12 (10)	140		
	JVB-165-Z/18	JVB-165-ZS/18	125	30-70	75	12 (10)	165		
	JVB-190-Z/18	JVB-190-ZS/18	150	55-95	75	12 (10)	190		
	JVB-215-Z/18	JVB-215-ZS/18	175	80-120	75	12 (10)	215		
	JVB-240-Z/18	–	200	105-145	75	12 (10)	240		

JVB-V connection strap (for transverse tensile loads)²⁾

Type	Max. V_{Rd} kN ³⁾	Adjustment range $l^{(2)}$ mm	Length L_1 mm	Length L_2 mm	For bolts ^{1), 4)}
 Eccentric insert JVB-V-2815-108	5.0	± 9	10	273	M12
JVB-V-3817-122	10.0	± 14	12	327	M12
JVB-V-5030-152	17.2	± 17	22	392	M16

JVB-N connection straps (for longitudinal tensile loads)²⁾

Type	Max. N_{Rd} kN ³⁾	Spacing e mm	Adjustment range $l^{(2)}$ mm	Length L_1 mm	Length L_2 mm	For bolts ^{1), 5)}	
 Toothed locking plate JVB-N-2815-55 JVB-N-2815-60 JVB-N-2815-80	5.0	55	24	10	92	M12	
JVB-N-3817-55 JVB-N-3817-65 JVB-N-3817-80		10.0	55		21		88
JVB-N-5030-60 JVB-N-5030-70 JVB-N-5030-80			17.2		60		27
	70			45	122		
	80	66		143			

¹⁾ Bolt(s) for anchor channel in wall element (see sketch „JVB connection straps“, page 62), which you need for mounting the connection strap. Please order separately.

²⁾ Perpendicular to anchor channel. The actual adjustment range depends on concrete element geometries, edge clearances and joint arrangements.

³⁾ The load-bearing capacity of the entire fastening system (connection strap set) depends on the boundary conditions such as concrete quality, edge clearances, joints etc. Therefore, the actual load-bearing capacity to be assumed can only be determined with the help of a design aid (see www.pohlcon.com).

⁴⁾ Fits through hole of eccentric insert.

⁵⁾ Fits through hole of toothed locking plate.

Example order for JVB-Z connection strap for wall spacing $a = 40$ mm

Type	Length L_2	Series	Version
JVB	115	Z/12	A4



Notes

During installation, please ensure that the connection straps are flush with the anchor channel and the component.

Other accessories

Locking plates JGM

$$\text{Perm. F} = \frac{F_{Rd}}{1.4}$$

Usage



JORDAHL® locking plates (threaded plates) can be installed at any point on the corresponding channel. The threaded hole is centred by a 90° turn after insertion or tilting. Locking plates are preferably used for spaced mounting with long bolts or threaded rods. They do not have national technical approval due to their concealed mounting.

Hook-head locking plates

They are forged to an exact shape, therefore ensuring that they do not rotate in the wrong direction. To facilitate installation, we recommend a thin foam strip in the channel chamber.

Hammer-head locking plates

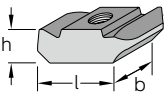
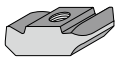
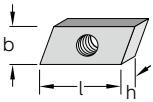
Hammer-head locking plates can be used to temporarily fix in place components of minor importance. They merely clamp the element in place without any special form fit like the hook-head locking plates.

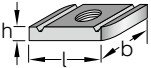
Hook-head locking plates (forged)	Type	Geometry l × b × h	With thread	F _{Rd} kN ¹⁾	Version	Matching profile	
	JGM A	57 × 31 × 22	M20	37.8	4.6 gv	K 72/48 W 72/48	
	JGM B	41 × 21 × 16	M6	3.1	4.6 gv A4-50	K 48/26 W 50+ W 50/30 K 50/30 K 50/40 W 53/34 K 53/34 W 55/42	
			M8	5.6			
			M10	9.0			
			M12	13.0			
			M16	16.8 24.2 ²⁾			
	JGM C	32 × 17 × 11	M6	3.1	4.6 gv A4-50	W 40+ W 40/22 K 40/25 K 40/22	
			M8	5.6			
			M10	9.0			
			M16	11.2			
	JGM H	30 × 14 × 6	M5	2.2	4.6 gv A4-50	K 38/17 K 36/36 K 36/20	
			M6	3.1			
			M8	5.6			
	JGM D	21 × 12 × 4	M10	9.0	4.6 gv A4-50	K 28/15 K 28/28 K 28/12	
			M12	9.8			
			M4	1.4			
			M5	2.2			
	JGM G	16 × 12 × 4	M6	3.1	4.6 gv A4-50	K 21/12	
			M8	3.5			
			M4	1.4			
			M5	2.2			
Anchor nuts	Type	Geometry l × b	With thread	h	F _{Rd} kN ¹⁾	Version	Matching profile
	JAM 22	35 × 20	M6	6.0	3.1	4.6 gv	K 41/41
			M8	6.0	5.6		
	JAM F 22 with spring		M10	8.0	9.0		
			M12	9.5	11.2		

¹⁾ The load capacities of the anchor channels according to the ETA and of the mounting profiles according to pages 52 and 53 are to be observed. The lower value is decisive in each case.

²⁾ 24.2 kN only permissible in profiles W53/34 and W55/42.

Threaded rods DIN 976-1 (Length L = 1000 mm)

	M6	M8	M10	M12	M16	M20
Load capacity F_{Rd} kN	3.1	5.6	9.0	13.0	24.0	37.8
Version	4.6 gv, A4-50					



Clamping plates, clamping claw

JORDAHL® clamping plates are suitable for fastening standard profiles from the I and IPB series as well as crane rails.

Version: fv

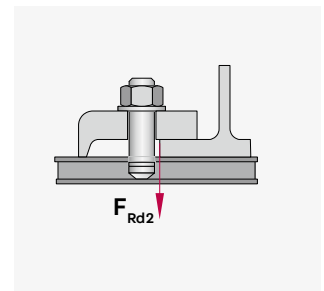
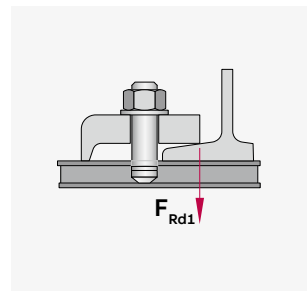

KPA clamping plate for crane rails ¹⁾	Type	For crane rails		a	b	For bolts ¹⁾	d	e
				mm	mm		mm	mm
	KPA 45	A 45	(KS 22)	22.0	8.5	M20	Ø 22	18
	KPA 55	A 55	(KS 32)	22.5	9	M20	Ø 22	18
	KPA 65	A 65	(KS 43)	23.5	10	M20	Ø 22	18
	KPA 75	A 75	(KS 56)	24.5	11	M20	Ø 22	18

KP clamping plate (DIN 3568)	Type	h mm	For bolts Ø	Suitable for I-beam ⁵⁾	IPB-beam (HEB) ⁵⁾	F_{Rd} kN in acc. w/ DIN 3568	
	LL 18 x 24 (14 x 20)	KP 50/7 ⁴⁾	7	M12 x 50	80 - 120	-	$F_{Rd} = 5.25$ kN
		KP 60/10	10	M16 x 80	120 - 160	100	$F_{Rd1} = 9.8$ kN
		KP 60/11	11	M16 x 80	180 - 200	120	
		KP 60/12 ²⁾	12	M16 x 80	220 - 240	140	
		KP 60/14 ³⁾	14	M16 x 80	260 - 280	160 - 180	$F_{Rd2} = 15.8$ kN
		KP 60/16	16	M16 x 80	300 - 340	200 - 220	
		KP 60/18	18	M16 x 80	360 - 380	240 - 260	
		KP 60/20	20	M16 x 80	400 - 450	280 - 300	

Universal clamping claw with washer	Type	Clamping height h mm	Bolt dimensions mm	F_{Rd} kN
	SKU	5-40 (35) ⁶⁾	M12 x 100 (80) ⁶⁾ Strength class 8.8 Washer 13.0 ISO 7093-1 (DIN 9021)	$F_{Rd} = 7.0$ kN

¹⁾ Crane rails in acc. w/ DIN 536, upon request:
 M16 Ø 18, M24 Ø 26.
²⁾ Also for crane rails A100 (KS75).
³⁾ Also for crane rails A120 (KS101).
⁴⁾ Dimensions for clamp in the sketch on the left.
⁵⁾ Other beam types also possible.
⁶⁾ 35 mm for bolt length of 80 mm.

Example order for locking plate

Type	Thread	Version
JGM B	M12	gv

Example order for clamping plate

Type	Ø	Version
KPA 55 - 22		fv

Clamp connections JSV

$$\text{Perm. } F = \frac{F_{Rd}}{1.4}$$

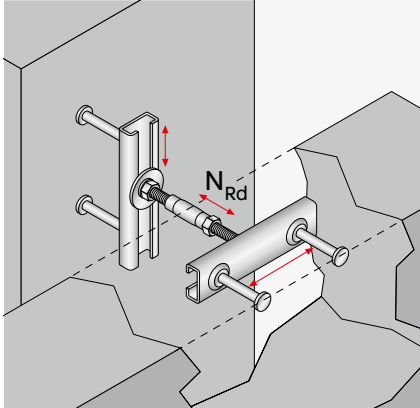

Clamp connection JSV for three-dimensional alignment

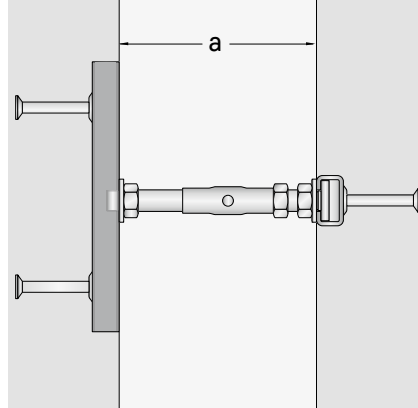

Installation overview

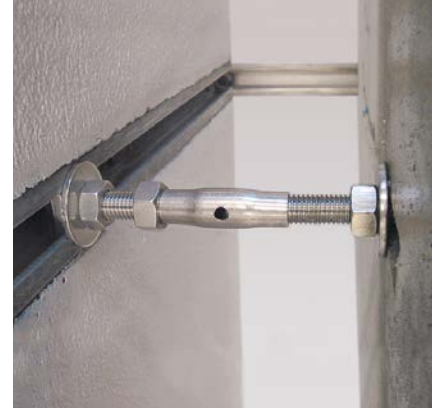

JORDAHL® clamp connections provide a backlash-free, tension- and compression-resistant connection between two components. The arrangement with a vertical and a horizontal JORDAHL® anchor channel (minimum length 150 mm) allows for exact, three-dimensional alignment of the fastening.

Scope of delivery

JORDAHL® clamp connections consist of:

- Clamp sleeve (1x)
- JORDAHL® bolt L incl. nut with left-hand thread (1x)
- JORDAHL® bolt R incl. nut with right-hand thread (1x)
- One nut to lock the clamp sleeve in place
- Washers EN ISO 7093-1 (2 x)

Type	N_{Rd} kN	Wall spacing ¹⁾ a mm	Clamp sleeve M × L	Bolt left-hand thread	Bolt right-hand thread	Matching short anchor channel piece l = 150 – 250 mm
JSV-28-1	± 4.9	85–110	SP 10 × 50	JDL M10 × 50	JD M10 × 40	JTA K 28/15
JSV-28-2		110–160	SP 10 × 80	JDL M10 × 50	JD M10 × 60	
JSV-38-1	± 7.0	95–115	SP 12 × 50	JHL M12 × 50	JH M12 × 50	JTA K 38/17
JSV-38-2		115–155	SP 12 × 80	JHL M12 × 50	JH M12 × 60	
JSV-38-3	± 9.8	145–195	SP 12 × 80	JHL M12 × 50	JH M12 × 100	
JSV-38-4		95–115	SP 16 × 50	JHL M16 × 50	JH M16 × 50	
JSV-38-5		125–175	SP 16 × 80	JHL M16 × 50	JH M16 × 80	JTA K 38/17
JSV-38-6		145–195	SP 16 × 80	JHL M16 × 50	JH M16 × 100	
JSV-40-1	± 11.1	95–115	SP 16 × 50	JCL M16 × 50	JC M16 × 60	JTA K 40/25
JSV-40-2		125–145	SP 16 × 80	JCL M16 × 50	JC M16 × 60	JTA W 40/22
JSV-40-3		140–185	SP 16 × 80	JCL M16 × 50	JC M16 × 100	JTA W 40+
JSV-50-1	± 14.0	125–165	SP 16 × 80	JBL M16 × 80	JB M16 × 50	JTA K 50/30
JSV-50-2		150–195	SP 16 × 80	JBL M16 × 80	JB M16 × 80	JTA W 50/30
						JTA W 50+
JSV-50-3		170–215	SP 16 × 80	JBL M16 × 80	JB M16 × 100	JTA K 53/34 JTA W 53/34 JTA W 55/42

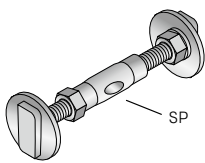

¹⁾ For all load levels, wall spacing can be varied via customised right-hand thread bolts.

Example order for clamp connection JSV N_{Rd} 7.0 kN, existing wall spacing 120 mm

Type	Profile size	Series	Version
JSV	- 38	- 2	- A4

Material

- Stainless steel (A4)

Pressure bolts JDS

$$\text{Perm. } F = \frac{F_{Rd}}{1.4}$$

JORDAHL® pressure bolts JDS are spacer bolts. They are mainly used in the assembly of prefabricated elements and serve to transmit compressive forces from dead weight or wind loads. Tensile forces cannot be borne.

Components

The construction consists of:

- A plastic sleeve with nail plate which is placed in the prefabricated element or in cast-in-place concrete
- A matching bolt with nut and washer made of stainless steel (A4)

Bolt length mm	For wall spacing $a \pm 20$ mm	Compressive force F_{Rd} ¹⁾ kN			
		M10	M12	M16	M20
80	40	10.2	15.4	30.0	47.0
100	60	9.1	14.0	28.0	45.6
120	80	8.1	12.7	26.2	43.1
140	100	7.3	11.6	24.5	40.9
160	120	6.4	10.6	23.0	38.8
180	140	5.7	9.7	21.4	36.7
200	160	5.2	8.8	20.0	34.7
220 ²⁾	180	4.6	8.0	18.6	32.9
240 ²⁾	200	4.2	7.3	17.4	31.2

¹⁾ Calculation of load-bearing capacity (steel failure) according to DIN 18 800 and Z-30.3-6 "Components and fasteners made of stainless steels".

²⁾ These lengths are special designs available upon request.

Construction notes

To allow for adjustment, the spacer bolt should be positioned approx. 15 cm from the edge of the prefabricated element. In this case, the edge clearance from the upper edge of the slab should be $a_r \geq 1.5 \times d$ (d = slab thickness). The transmission of forces in the concrete must be verified and ensured by sufficient reinforcement in the area of force transmission.

In combination with an eye socket (see page 68), the pressure bolt connection can also be braced against unintentional loosening.

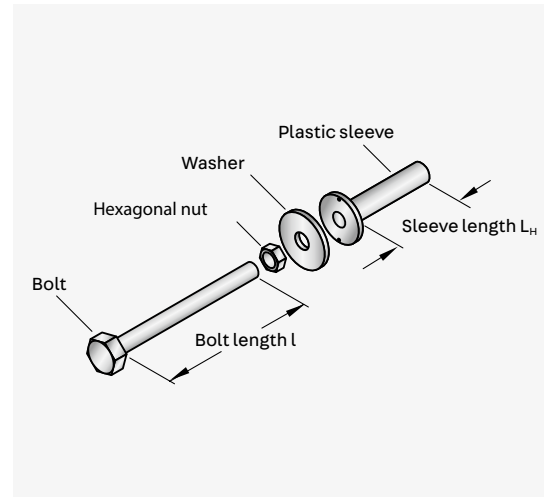

JORDAHL® pressure bolts

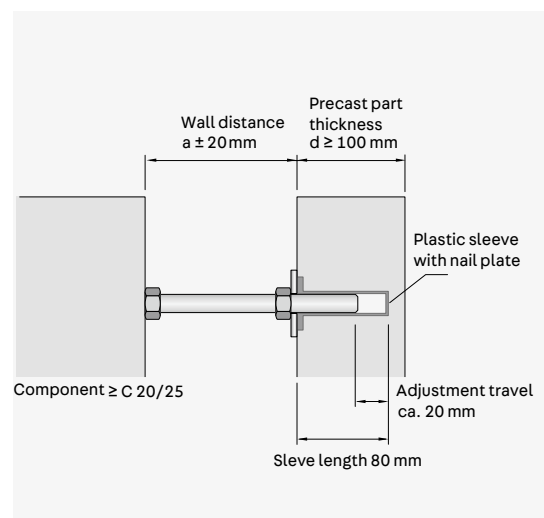

Installation

Example order for pressure bolt JDS

Type	Thread \emptyset	Bolt length mm	Version
JDS	M10 x	80	A4

Connecting sleeves

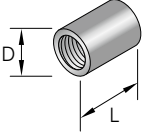
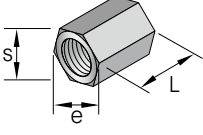
	Thread	D mm		L mm	F _{Rd} kN	Version	
Round 	M6	10.0		20.0	3.1	gv A4 upon request	
	M8	11.0		20.0	5.6		
	M10	13.0		25.0	9.0		
	M12	15.0		30.0	13.0		
	M16	22.0		40.0	24.0		
	M20	28.0		50.0	37.8		
	Thread	e mm	s mm	L mm	F _{Rd} kN		Version
Hexagonal ¹⁾ 	M6	11.05	10.0	15.0	A4-50	4.6	gv A4 upon request
	M8	14.38	13.0	20.0	3.5	4.0	
	M10	18.90	17.0	25.0	6.4	7.4	
	M12	21.10	19.0	30.0	10.1	11.6	
	M16	26.75	24.0	40.0	14.8	16.9	
	M20	32.95	30.0	50.0	27.4	31.4	
					42.8	49.0	

¹⁾ With inspection opening upon request.

Eye sockets/sleeve dowels

JORDAHL® eye sockets are used to transmit tensile forces into concrete components, such as those which occur during the transport of prefabricated elements. The eye sockets are concreted into the reinforced concrete components.

A reinforcing bar is required as a suspension reinforcement to transfer the forces. For this purpose, a bar with the largest possible bar diameter is passed through the transverse hole and bent.

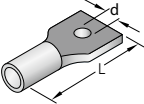
	Thread	L mm	d mm	F _{Rd} kN	Min. a _{r1} mm	Version
	M8	50	6.2	3.5	75	A4, gv
	M10	50	6.2	4.9	75	
	M12	60	7.2	7.0	90	
	M16	80	12.2	11.2	120	

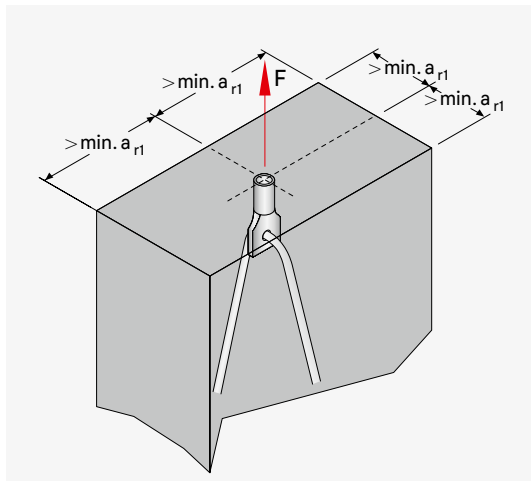

Example order for eye socket

Type	Thread Ø	Length mm	Version
ÖM	M10	x 50	A4

Profiled metal sheet channels JTB



JORDAHL® profiled metal sheet channels JTB are the ideal solution for attaching trapezoidal sheet metal to reinforced concrete components without damaging the load-bearing components. The channel types JTB-AR and JTB-uni are available.



Benefits

- National technical approval no. **Z-21.4-161**
- Slim anchor shapes that fit easily into the reinforcement
- Fast installation in a single operation
- Surface-flush, direct concreting into the load-bearing component
- Suitable for all standard construction installation situations
- Guaranteed load-bearing capacity thanks to national technical approval
- With approved end anchor for individual cutting of the channel to length



Profiled metal sheet channel JTB-AR

- With centrally arranged loop anchors
- For easy installation with easier fitting into existing reinforcement cages



Profiled metal sheet channel JTB-uni

- With externally arranged, slender anchors with roof-shaped anchor tip
- For fast installation, even with heavily reinforced components
- Minimal space requirements, as they can be stacked on top of each other

Applications and fields of use

JORDAHL® profiled metal sheet channels enable fast, cost-effective installation of trapezoidal sheet metal on reinforced concrete components. The anchors of conventional fastening channels often had difficulty fitting into pre-bonded reinforcement cages. The uni profiled metal sheet channels JTB-AR and JTB from JORDAHL are easier to install into existing reinforcement thanks to their slim anchor shapes.

The right fastening channel from JORDAHL is available for every installation situation and every degree of reinforcement. The types JTB-AR and JTB-uni are suitable for all standard construction installation situations JORDAHL® profiled metal sheet channels and the matching end anchors have national technical approval: **Z-21.4-161**.

Material

- Steel according to DIN EN 10 025, hot-dip galvanized with $\geq 50 \mu\text{m}$ zinc coating.
- Stainless steel

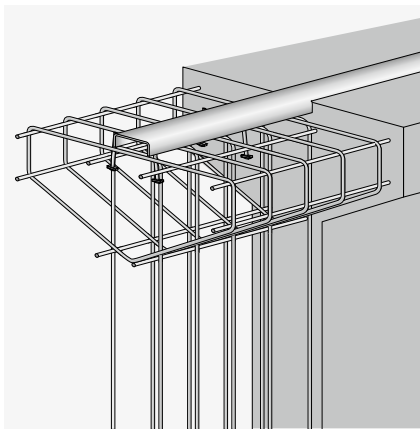

Installation in heavily reinforced structural elements

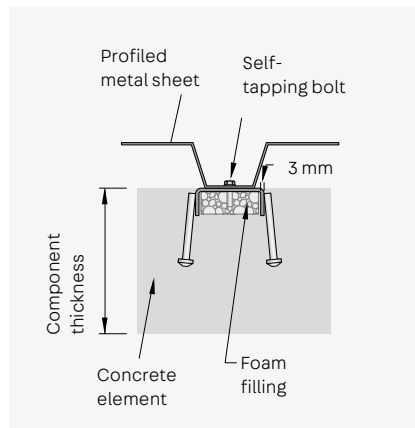

JTB-uni

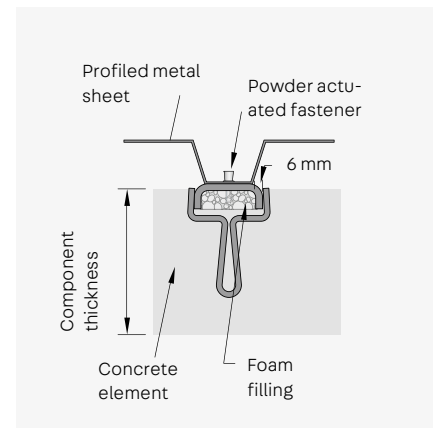

JTB-AR



Fixed to the wall



Attached on roof



Storage of JTB-AR



JTB-uni with small space requirements

Technical data

Delivery variants

The profiled metal sheet channels JTB-AR and JTB-uni are supplied in two standard variants (stock length 3000 mm each).

- Can be divided in the middle, often making it particularly cost-effective Anchor spacing $e = 450$ mm

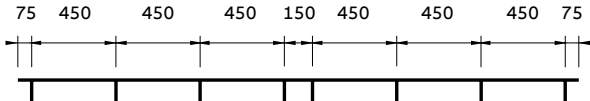

- Can be divided as required, anchor spacing $e = 150$ mm

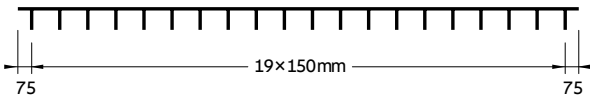

For special cases that cannot be covered by these delivery variants, end anchors with national technical approval are available that are fastened to the channels with self-tapping bolts.

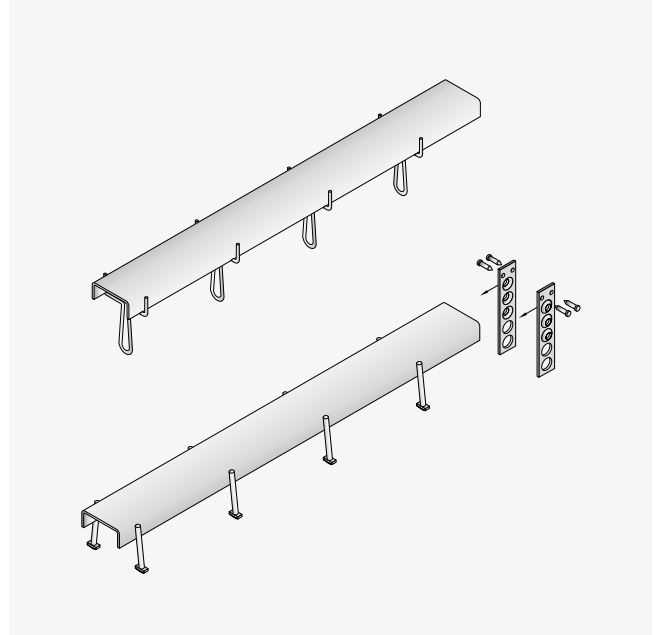

JTB-uni and JTA-AR with matching end anchors

Technical data

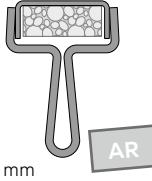
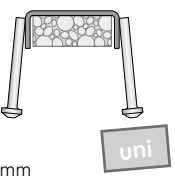
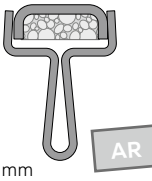
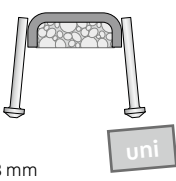
	JTB 60/22/3-AR	JTB 60/22/3-uni	JTB 60/22/6-AR ²⁾	JTB 60/22/6-uni ²⁾
Installation height	 100 mm	 68 mm	 100 mm	 68 mm
Anchor spacing e mm	150; 450			
Cross section A cm²	2.97		5.06	
Moment of inertia I_y cm⁴	1.51		1.88	
Moment of resistance W_y cm²	0.87		1.286	
Weight with anchors kg/m	2.5	2.4	4.1	4.0
Materials and corrosion protection	S235JR, hot-dip galvanised $\geq 50 \mu\text{m}$ or A4			
Fasteners¹⁾ for profiled metal sheet channels in the version	fv	e.g. EJOT self-drilling bolt: JT 2-6-6.3 \times 22, V16		e.g. EJOT powder actuated fastener: SBR 14
	Stainless steel	e.g. EJOT Cronimax: JZ 7-6.3 \times 22, E16 pre-drilled \varnothing 5.5 mm		

¹⁾ The manufacturer's approvals must be observed.

²⁾ Only in fv

Technical data

$$\text{Perm. } F = \frac{F_{Rd}}{1.4}$$

Rated resistance F_{Rd}

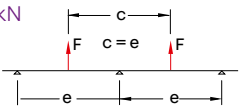
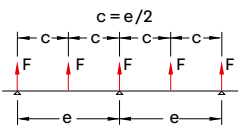
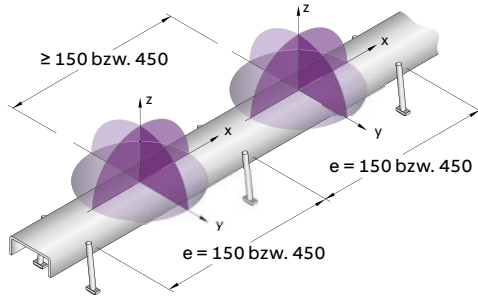
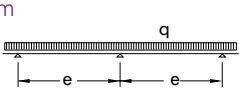
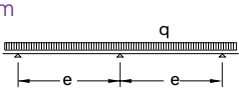
Profile	JTB 60/22/3		JTB 60/22/6		Load areas
Anchor spacing e mm	150	450	150	450	
Single load F_{Rd} kN					$\sqrt{N_{Ed}^2 + V_{Ed}^2 + X_{Ed}^2} \leq F_{Rd}$ 
	7.0	4.6	7.0	7.0	
	3.5	3.5	3.5	3.5	
Line load q kN/m					
	46.6	15.5	46.6	15.5	

Installation and assembly

Profiled metal sheet channels with foam filling inserts are concreted into the smooth and level concrete surface of the load-bearing structural member flush with the surface and in true alignment. Butt joints between two fastening channels should be approx. 20 mm. After stripping the formwork, the profiled sheets are fastened to the channel using approved fasteners, self-tapping bolts or powder actuated fasteners.

End anchors

Hot-dip galvanized fastening channels that are individually shortened are secured at the end using end anchors with national technical approval. The end anchors are fastened 75 mm from the end of the channel.

ST 4.8 × 16 gv self-tapping bolts in acc. to DIN EN ISO 15481 can be used as fasteners for the end anchors.

The fastening of the profiled steel must be made in the middle third of the width of the rear of the channel. The axis of the bolt must be at least 2.5 cm from the end of the channel. The applicable standards and regulations for trapezoidal sheets and fasteners must be observed.

Rated resistance F_{Rd}

Fastening channel	End anchors	F_{Rd} kN
JTB-uni	JTB-EB	4.9

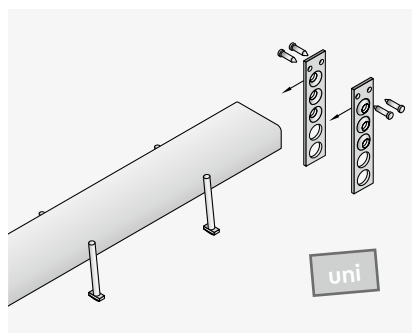

JTB-uni channel with JTB-EB end anchors

Minimum spacing mm

	a_a ¹⁾	a_r ²⁾	a_e ³⁾	a_f ⁴⁾	d ⁵⁾	b ⁶⁾
Type JTB-AR	200	100	20	20	100 + c	200
Type JTB-uni	200	120	20	20	68 + c	240
JTB-EB end anchor	200	100	20	20	125 + c	200

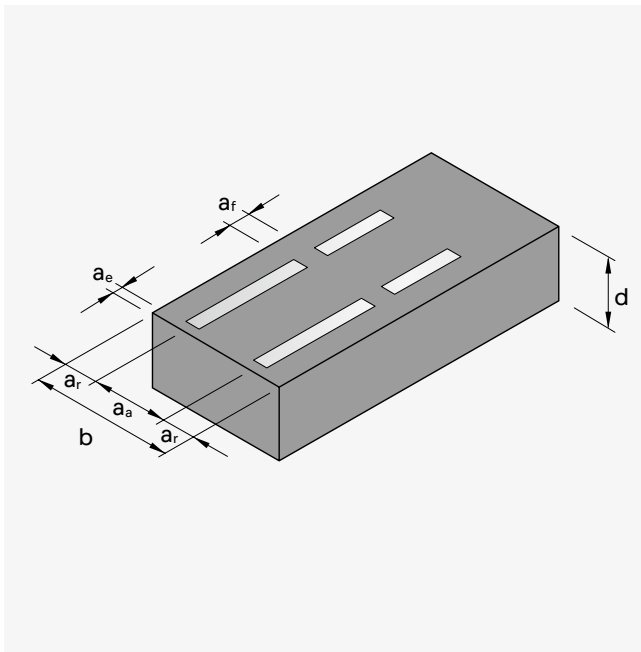

- ¹⁾ If adjacent channels are staggered such that their anchors are 150 mm apart, the edge clearance a_a may be reduced to 80 mm.
- ²⁾ If the anchor load is not fully utilized, the edge distance a_r may, provided there is only one centric tension load, be **reduced** to:
red. $a_r = N_{Ed}/N_{Rd} \times a_r \geq 5 \text{ cm}$
 N_{Ed} = rated force
 N_{Rd} = rated resistance
- ³⁾ With full utilization of the anchor force, the last anchor must be at least 90 mm from the edge.
- ⁴⁾ When the anchor force is fully utilized, the last two end anchors must be at least 150 mm apart.
- ⁵⁾ Is given by the geometry of the anchors and the required concrete cover c according to DIN EN 1992-1-1 in conj. w/ DIN EN 1992-1-1/ NA:2011-01, Section 4.4.
- ⁶⁾ Minimum component width when a channel is installed.

Example order for profiled metal sheet channel JTB

Type	Size	Anchor spacing mm	Anchors	Material
JTB	60/22/3	- 450 -	uni -	A4



Installation of a multi-layer insulated profiled sheet metal wall.

Products for wall connection

Brick tie anchor JMA and nail anchor JNA

JORDAHL's wall connection anchors combined with the corresponding rails or windposts from JORDAHL ensure the permanent and secure connection of masonry to adjacent reinforced concrete components. They are available both for wide joints as a thick-bed variant and for thin joints as a thin-bed variant in the two series 12 and 18 for different profiles. The straight form, the T-form and the L-form are suitable for connecting clinker masonry, and the thin-bed JMA-D in the

adhesive joint is recommended for large-format aerated concrete.

The nail anchors JNA and the corresponding anchor or wall connection channels ensure the permanent and secure connection of wood components to adjacent reinforced concrete components. One example is rafter fastening with nail anchors to ring beams.

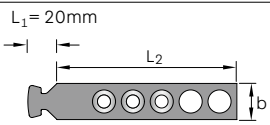
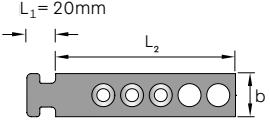
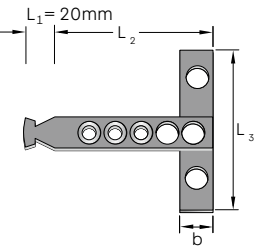
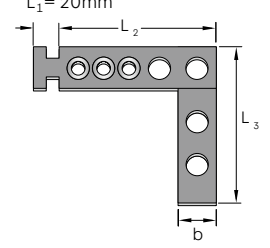
Brick tie anchor JMA for thick-bed mortar Version: fv, A4		Shell spacing			Dimensions	
		a mm	b mm	t mm	L ₂ mm ¹⁾	L ₃ mm
	JMA-L ₂ /12 (Series 12) ¹⁾	20-40	25	2	85	-
		40-80	25	2	120	-
		85-140	25	2	180	-
		140-160	25	3	300	-
	JMA-L ₂ /18 (Series 18)	20-40	30	3	85	-
		40-80	30	3	120	-
		85-140	30	3	180	-
		140-160	30	3	300	-
	JMA-L ₂ × L ₃ -Q /12 (Series 12)	20-40	25	2	85	120 180 300
		40-80	25	2	120	
		85-140	25	2	180	
		140-160	25	3	300	
	JMA-L ₂ × L ₃ -Q /18 (series 18)	20-40	30	3	85	
		40-80	30	3	120	
		85-140	30	3	180	
		140-160	30	3	300	
	JMA-L ₂ × L ₃ -QE /12 (series 12)	20-40	25	2	85	120 180 300
		40-80	25	2	120	
		85-140	25	2	180	
		140-160	25	3	300	
	JMA-L ₂ × L ₃ -QE /18 (series 18)	20-40	30	3	85	
		40-80	30	3	120	
		85-140	30	3	180	
		140-160	30	3	300	

¹⁾ The necessary length L₂ is to be determined by taking into account the thickness of the facing shell (embedding depth ≥ 50 mm).

Example order for JMA-QE brick tie anchor

Type	Length L ₂ × L ₃	Variant	Series	Version
JMA	- 85 × 120	- QE	/ 12	A4

Example order for JMA brick tie anchor

Type	Length	Series	Version
JMA	120 /	12	A4

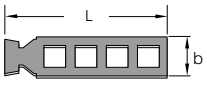
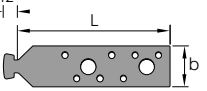
	Dimensions		Length		Dimensions		Length
	b mm	t mm	L mm		b mm	t mm	L mm
Brick tie anchor JMA for thin-bed mortar – version: A2 JMA-L-D/12 (Series 12) 	25	1	125	JNA nail anchor Version: fv JNA-L/12 (series 12) JNA-L/18 (series 18) (no image) 	35	3	100
			185				130
			245				200

Brick tie channels

Connection

There are several connection options for the JORDAHL® brick tie anchor JMA to ensure the permanent and secure connection of masonry to adjacent building components.

- JORDAHL® anchor channels JTA
- JORDAHL® mounting channel JM, which can also be mounted on wood and steel components
- JORDAHL® brick tie channel Kt 25/15-D with integrated, bendable dent anchors in the delivery lengths 2.5 m and 5.0 m

Material

The brick tie channels and anchors are manufactured in stainless steel for use in facade areas. Hot-dip galvanised products can be used for interior applications.

Dimensioning

All channels are available in various cross-sections matched to the loads.

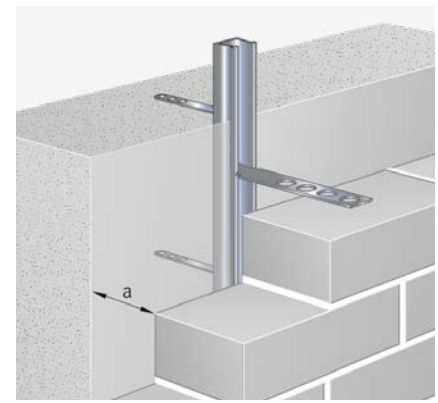

Connection of facing shells to reinforced concrete components with brick tie channel Kt 28/15-D and anchor

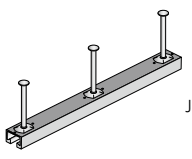
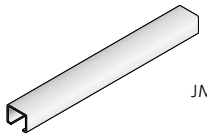
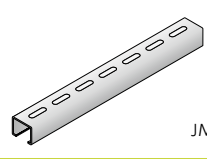

Connection of facing masonry to bulkhead wall

Brick tie channels	Version	Corresponding brick tie anchor and nail anchor
 JTA  JM  JML	JTA K 28 / 15 JM K 28 / 15 JML K 28 / 15 JTA K 38 / 17 JM K 38 / 17 JML K 38 / 17	fv A2 A4 fv A2 A4 sv ¹⁾ A4
		JMA-L ₂ /12 JMA-L ₂ × L ₃ -Q/12 JMA-L ₂ × L ₃ -QE/12 JMA-L-D/12 JNA-L/12 (Series 12) JMA-L ₂ /18 JMA-L ₂ × L ₃ -Q/18 JMA-L ₂ × L ₃ -QE/18 JNA-L/18 (Series 18) JMA-L ₂ /12 JMA-L ₂ × L ₃ -Q/12 JMA-L ₂ × L ₃ -QE/12 JMA-L-D/12 JNA-L/12 (Series 12)

¹⁾ sv = sendzimir galvanised

Scaffold shoes JG

JORDAHL® scaffold shoes JG are used for the safe installation of assembly platforms in lift shafts. Scaffold shoes are available in different designs for various load levels. The standard version is designed for squared lumber widths of

10 cm. Squared lumber widths of 12 cm are available upon request. They are made of hot-dip galvanized steel or are supplied with a coloured anti-corrosion coating according to the load level.

Type H

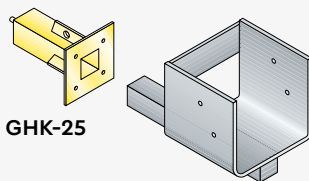

GHK-25

Type H 2.5

$V_{Rd} = 4.2 \text{ kN}^{1)}$

Type K

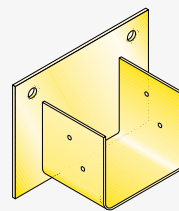

Type K4

$V_{Rd} = 6.2 \text{ kN}^{1)}$

Type L

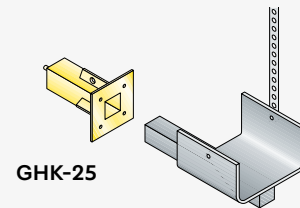

GHK-25

Type L 2.5²⁾

$V_{Rd} = 4.2 \text{ kN}^{1)}$

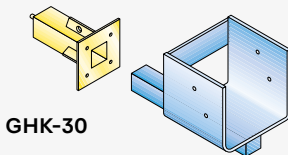

GHK-30

Type H5

$V_{Rd} = 7.7 \text{ kN}^{1)}$

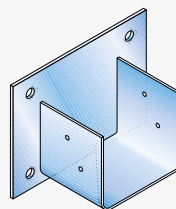

Type K9

$V_{Rd} = 13.9 \text{ kN}^{1)}$

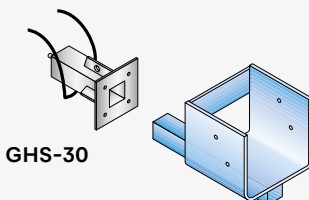

GHS-30

Type H9

$V_{Rd} = 13.9 \text{ kN}^{1)}$

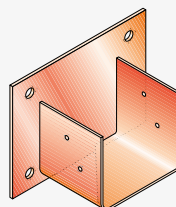

Typ K12

$V_{Rd} = 18.5 \text{ kN}^{1)}$

Example order for scaffold shoes JG

Type

JG - K4

Example order for sleeves

Type

GHK

Size

25

¹⁾ Rated resistance incl. load increase factor 1.1.

²⁾ Scaffold shoe for squared timber width: 12 cm (10 cm with price possible on request)



Information

Would you like to learn more about JORDAHL products?
 Visit us at www.pohlcon.com → Downloads → Brochures.

Edge protection angles JKW

JORDAHL® edge protection angles JKW for setting in concrete secure the corners of columns and walls, e.g. in parking garages and high-bay warehouses. They are supplied ready for installation with anchors. The U-shaped BST anchors are easy

to fit into the reinforcement cage and do not obstruct the corner reinforcement. The edge protection angle is bent at an angle of 92°. This ensures good contact with the formwork and a clean concrete finish.

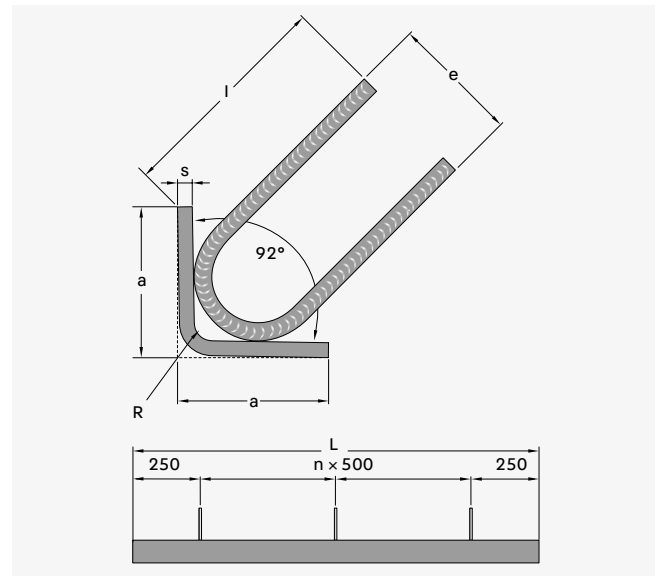

Material

Angle

- hot-dip galvanized (fv)
- stainless steel (A4)

Anchors

- mild steel

Type	Angled bracket dimensions $a \times a \times s$ mm	Available lengths L mm	No. of anchors Ea.	Approx. anchor dimensions $l \times e$ mm	Angle of bend Bending radius R mm
JKW-50/5-L	50 × 50 × 5	500, 750, 1000	2	80 × 50	5
		1500	3		
		2000	4		
JKW-80/6-L	80 × 80 × 6	500, 750, 1000	2	125 × 50	13
		1500	3		
		2000	4		
JKW-100/6-L	100 × 100 × 6	500, 750, 1000	2	115 × 50	13
		1500	3		
		2000	4		
JKW-100/8-L	100 × 100 × 8	500, 750, 1000	2	115 × 50	13
		1500	3		
		2000	4		

Example order for JKW edge protection angles

Type	Profile size	Length mm	Material
JKW	80/6	750	A2

Profile brackets JKO

JORDAHL® profile brackets JKO 28/28-1, 36/36-1 and 36/36-2 are ready-to-install constructions for holding clamps, pipes, cable trays and other elements. They are fastened to anchor channels or directly to the component with dowels. Special designs are also available upon request.



$$\text{Perm. } F = \frac{F_{Rd}}{1.4}$$

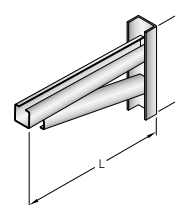
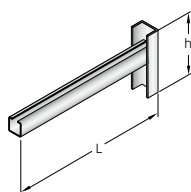

JKO 28/28-1

JKO 36/36-1

JKO 36/36-2

Profile	K 28/28	K 36/36	K 36/36				
Matching bolt	Type JD, M6 - M12	Type JH, M10 - M16	Type JH, M10 - M16				
Connecting profile for bolts	U 36/24 M12	U 45/27 M12	U 45/27 M12				
Length L mm	100, 200, 300, 400	300, 400, 500, 600	300	400	500	600	700
Total height h mm	120	180	208	238	269	300	330
Material/Version	Steel, hot-dip galvanised $\geq 50 \mu\text{m}$, stainless steel upon request						

N_{Rd} kN¹⁾

Load case 1:

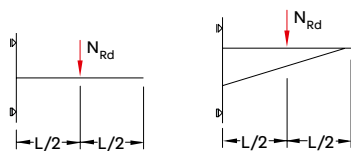

Length L mm

Load case 2:

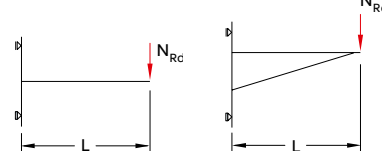

Length L mm

	100	200	300	400	500	600	700	100	200	300	400	500	600	700
JKO 28/28-1	3.78	1.89	1.26	0.98	-	-	-	1.89	0.95	0.63	0.49	-	-	-
JKO 36/36-1	-	-	2.80	2.10	1.68	1.40	-	-	-	1.40	1.05	0.84	0.70	-
JKO 36/36-2	-	-	7.00	5.81	4.41	3.57	2.94	-	-	5.88	5.74	5.11	4.69	4.41

¹⁾ All load capacities were calculated elastically-plastically in acc. w/ DIN 18 800 (1/90) with the following assumptions:
 $\gamma_F = 1.4$; $\gamma_{MS} = 1.1$; Yield strength $f_{y,k} = 235 \text{ N/mm}^2$; Deflection $f \leq 1 / 150$ for steel.

Example order for JKO profile bracket

Type	Profile size	Length mm	Version
JKO	28/28-1	200	fV

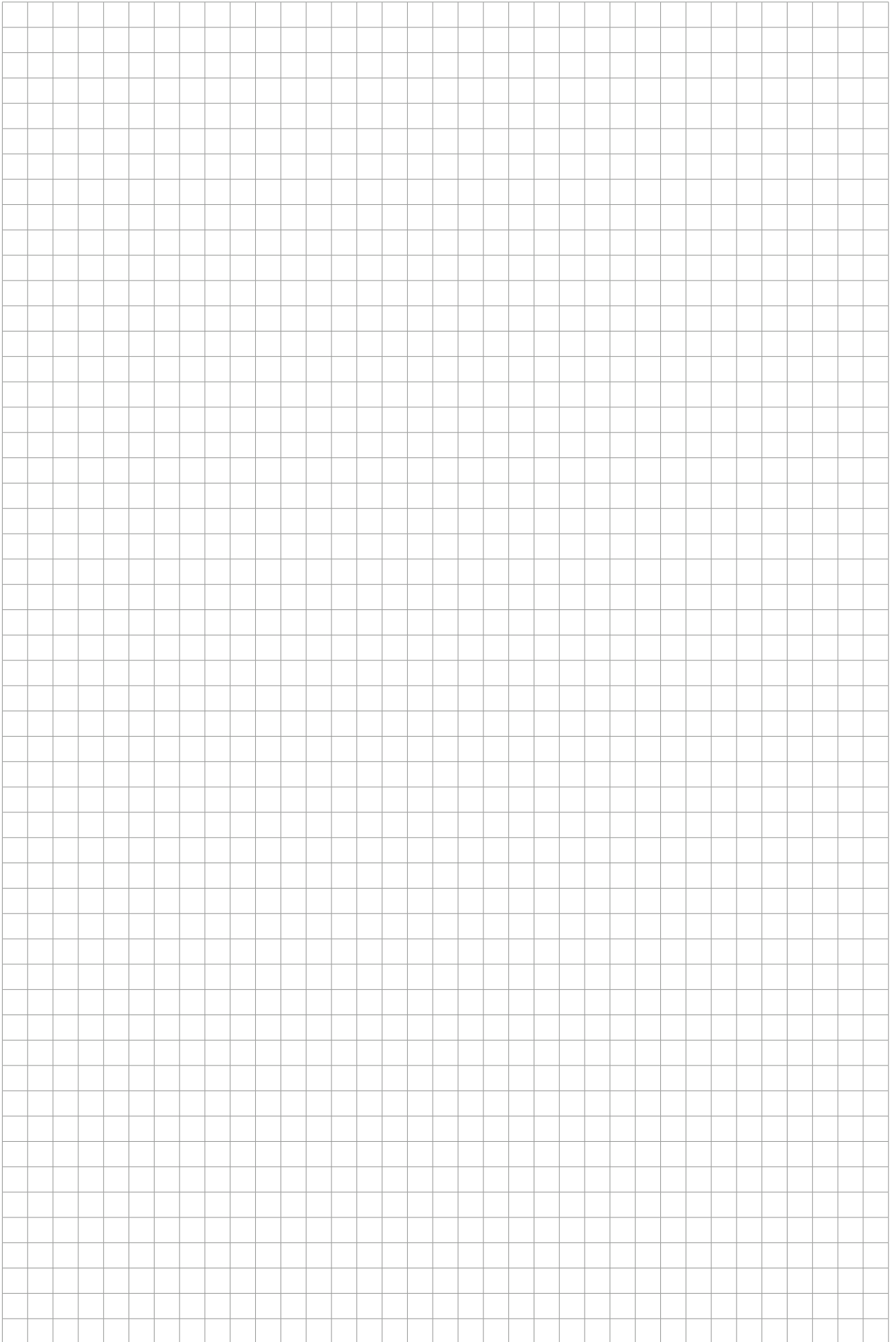

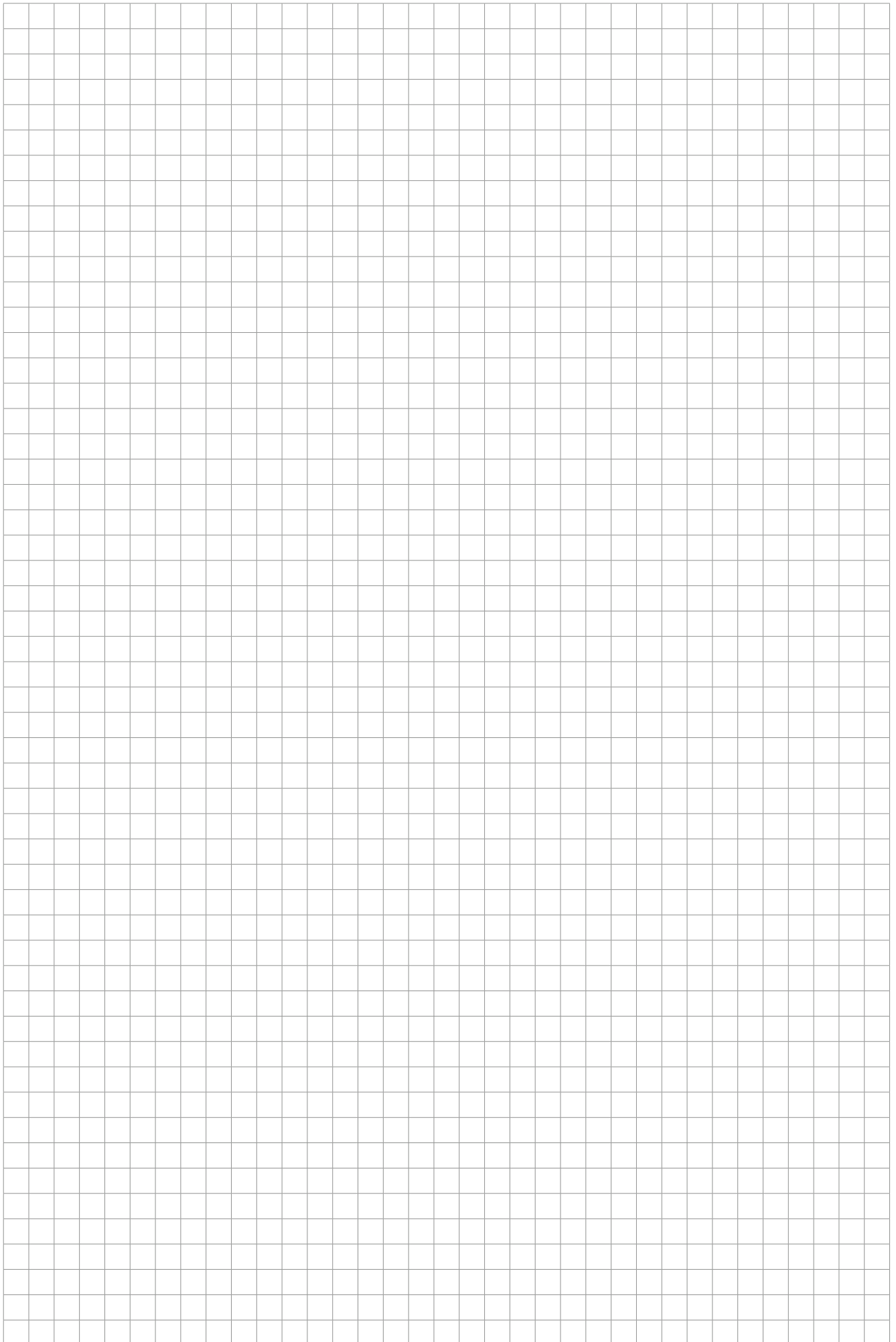

Index

A

Anchor nuts JAM	64
Anchor channels	12
• Fire load	25
• Dynamic loads	26
• Corner pieces	38
• Curved anchor channels	32
• Railing fastening JGB	34
• Cold-formed profile JSA	39
• Hot-rolled and cold-formed profiles JTA-CE	12
• Facade fastening JTA-RF, JTA-RT	36
• Toothed hot-rolled profiles JXA	20
• Toothed hot-rolled profiles JXA-PC	21
• Toothed cold-formed profiles JZA	20
• Marking	10
• Installation	28
• Pairs	32
• Range JTA, JXA and JZA	24
Applications and fields of use	4
Approvals and certificates	8

B

Bolts	48
• Tightening torque/installation	29
• Loads on bolts	
in longitudinal direction of channel	58
• Determining the bolt length	49
• Hook-head t-bolts JA, JB, JE, JC	50
• Tee-head bolts JH, JD, JG	51
• Double-notch toothed t-bolts JKB, JKC	54
• Toothed t-bolts JXE, JXB, JXH, JXD, JZS	54
• Position marking	49
• Pretensioned bolt connections	56
• Accessories	59
Brick tie anchor JMA	74
Brick tie channels	75

C

Clamping claw SKU	65
Clamp connections JSV	66
Clamping sleeves SP	66
Clamping plates KP, KPA	65
Connecting sleeves round/hexagonal	68
Connection strap	62
• JVB-N	63
• JVB-V	63
• JVB-Z	63
• JVB-ZS	63
Corrosion protection	11

D

Double-notch toothed t-bolt JKB, JKC	54
--------------------------------------	----

E

Edge protection angle JKW	77
JORDAHL® EXPERT software	16
Eye sockets ÖM	68

F

Façade fastening channels	
JTA-RF, JTA-RT	36

H

Hexagon nuts in acc. w/ ISO 4032	61
Hook-head t-bolt JA, JB, JC, JE	50

L

Locking plates JGM	64
Locknuts	61

M

Marking	10
Materials	10
Mounting channels	40
• Welded or dowel-mounted	
mounting channels	43
• Cold-formed profiles JM K	44
• Hot-rolled profiles JM W	42
• Perforated mounting channel JML	45
• Hot-rolled profiles, toothed JXM	42
• Cold-formed profiles, toothed JZM	45
• Technical data	46

N

Nail anchor JNA	74
-----------------	----

P

Profile brackets JKO	78
Pressure bolts JDS	67
Profiled metal sheet channels JTB	69
• Applications and fields of use	70
• Installation and assembly	72
• Technical data	71

R

Railing fastening channels JGB	34
Rated resistance, JM W and JXM W	43
Rated values for stainless steel bolts	53
Rated values for steel bolts	52
Ring nuts RM in acc. w/ DIN 582	62

S

Scaffold shoes JG	76
Sleeve dowel	68
Spring washers DIN 127	61

T

Tee-head bolt JD, JG, JH	51
Threaded rods DIN 976-1	65
Toothed anchor channels	18
• Technical data	22
Toothed channels JXA, JZA, JXA-PC	
(see Toothed anchor channels)	18
• Technical data	22
Toothed t-bolts JXB, JXD, JXE, JXH, JZS	54
Toothed washer JKZS	61

V

Square bearing plate JVL	60
Pretensioned bolt connections	56

W

Washers	60
---------	----

Our synergy concept for you

With us, you benefit from the collective experience of three established manufacturers who combine their products and expertise to form a truly comprehensive range. This is the PohlCon synergy concept.



Full-service consulting

Our extensive network of advisors is available to answer all your questions about our products on site. You will enjoy personal support from our qualified staff right from the planning stage through to construction.



Digital solutions

Our digital services give you targeted planning assistance when using our products. We provide tailor-made planning support from tender specifications to CAD details, BIM data and modern software solutions.



Seven fields of application

We think in terms of holistic solutions. That is why we have grouped our products into seven fields of application in which you can benefit from the synergy of the PohlCon product range.

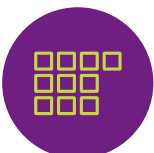

Ten product categories

The products are divided into ten product categories to help you find the right product from our extensive range even faster. This allows you to navigate through our products and quickly find what you need.



Custom solutions

Can't find a series product on the market that is suitable for your project? We master extraordinary challenges by harnessing the many years of expertise of our three manufacturer brands in the area of custom solutions. In this way, we can build unique construction projects together.

PohlCon GmbH

Nobelstr. 51
12057 Berlin
Germany

T +49 30 68283-04
F +49 30 68283-383

www.pohlcon.com