

General Building Code Test Certificate

- Translation -

Test Certificate No.: P-5120/231/09 MPA BS

Subject: „Pentaflex® KB, Pentaflex® FTS, Pentaflex® OBS,
Pentaflex® ABS and Pentaflex® Modul“

to be used for sealing construction joints and predetermined crack cross sections in concrete members with a high water penetration resistance in compliance with Verwaltungsvorschrift Technische Baubestimmungen No. C 3.30

Applicant: PohlCon GmbH
Nobelstraße 51
12057 Berlin

Date of first issue: 12/10/2009

Issue date: 27/09/2024

Valid until: 26/09/2029

This General Building Code Test Certificate (abP) consists of 7 pages and 17 annexes.

This translation is not tested by the testing laboratory. Authoritative is the German General Building Code Test Certificate. This translation may not be used in the German building control procedure.

A General provisions

- (1) This General Building Code Test Certificate (abP) attests that the construction product can be used within the meaning of federal state building code regulations.
- (2) The General Building Code Test Certificate (abP) does not replace any of the building permits, approvals and certificates required by law for the performance of building projects.
- (3) The General Building Code Test Certificate (abP) is issued without prejudice to the rights of third parties, in particular private property rights.
- (4) Producers and distributors of the construction product shall, without prejudice to any additional regulations set out under the special provisions below, furnish the user of the construction product with copies of the General Building Code Test Certificate (abP), and they shall in addition point out that the General Building Code Test Certificate (abP) must be available at the place of use of the construction product. Copies of the General Building Code Test Certificate (abP) shall be made available to the authorities concerned upon request.
- (5) The General Building Code Test Certificate (abP) may not be copied unless as a complete text. Excerpts of the Certificate may only be published with the prior permission of the Braunschweig Materials Testing Institute (MPA). The wording of, or drawings used in, advertising brochures must not be in conflict with the contents of the General Building Code Test Certificate. Translations of the General Building Code Test Certificate shall bear the note "translation of the German original not checked by the Braunschweig Materials Testing Institute".
- (6) The General Building Code Test Certificate (abP) is subject to revocation. The provisions may be subsequently amended or revised, in particular if and when required as a result of new technical findings.

B Special provisions

1 Test item and field of application

1.1 Test item

The General Building Code Test Certificate (abP) applies to the fabrication and use of the "Pentaflex® KB, Pentaflex® FTS, Pentaflex® OBS and Pentaflex® ABS" steel plate waterstops of PohlCon GmbH.

The Pentaflex® KB steel plate waterstop has the dimensions 167 mm x 1.2 mm, 120 mm x 1.2 mm and 80 mm x 1.2 mm (high x thick without protective strip) and comes with protective strips that can easily be pulled off.

The Pentaflex® FTS and Pentaflex® OBS steel plate waterstops are Pentaflex KB waterstop plates (dimensions: 167 mm x 1.2 mm) that are provided with additional profiled plates to generate predetermined break zones.

Pentaflex® ABS is a stopend element into which the Pentaflex® KB steel plate waterstops are pushed.

The PENTAFLEX® Modul consists of Pentaflex KB metal waterstops (dimensions 60 mm x 1.4 mm) which are installed in a sheet metal shell (height 30 mm, width 42 mm) and EPP filler strips (height 30 mm, width 20 mm) in conjunction with FERBOX® rebend connectors.

1.2 Field of application

The "Pentaflex® KB, Pentaflex® FTS, Pentaflex® OBS and Pentaflex® ABS" steel plate waterstop may be used for internal sealing of construction joints, vertical butt joints in element walls, and predetermined cracking cross sections (in-situ concrete structures) with a maximum opening width of 1.0 mm, and in concrete structures with a high water penetration resistance in accordance with Verwaltungsvorschrift Technische Baubestimmungen No. C 3.30 as a protection against:

- pressing water up a maximum water pressure of 2.0 bar (dimensions 167 mm x 1.2 mm),
- pressing water up a maximum water pressure of 1.0 bar (dimensions 120 mm x 1.2 mm and 80 mm x 1.2 mm)
- ground moisture and non-pressing water.

The Pentaflex® Modul may be used as an internal sealant for construction joints (in-situ concrete structures), with a maximum opening width of 0.25 mm, in structural components made of concrete with high water penetration resistance in accordance with Verwaltungsvorschrift Technische Baubestimmungen No. C 3.30 against:

- pressing water up to a maximum water pressure of 0.75 bar (dimensions 60 mm x 1.2 mm)
- ground moisture and non-pressing water

can be used.

The steel plate waterstops can be used in zones of frequently changing water levels. The sealing complies with utilisation-class A requirements for application classes 1 and 2 as set forth in the regulations for watertight structures (WU-Richtlinie)¹.

The steel plate waterstops must be applied as specified in section 4 (Execution).

2 Provisions concerning the construction product

2.1 Composition, properties and characteristics

The steel plate waterstops are galvanised steel plates that are provided with a bituminous coating on both sides. For shipment, the coating is protected with a film that is split in the middle.

The construction products have the characteristic values listed in Table 1 and must comply with them. Proof of the suitability for use of the metal waterstops was provided by tests carried out at the Materialprüfanstalt Stuttgart and the Materialprüfanstalt Braunschweig. Proof of the serviceability of the metal waterstops was provided by tests carried out at the Stuttgart Materials Testing Institute and the Braunschweig Materials Testing Institute in accordance with the Braunschweig, in accordance with the test principles for issuing general building authority test certificates for joint seals in components made of concrete with high water penetration resistance in areas in contact with the ground (PG-FBB), Part 1, May 2020 edition.

Construction joints and predetermined crack cross sections that are sealed with the „Pentaflex® KB, Pentaflex® FTS, Pentaflex® OBS, Pentaflex® ABS and Pentaflex® Modul“ steel plate waterstops

- provide adequate stability
- provide adequate adhesive strength
- are adequately impervious to water
- provide adequate age resistance

for the fields of application mentioned in section 1.2 above.

The construction products conform with building material class *E* requirements in accordance with DIN EN 13501-1.

2.2 Production, packaging, transport, storage, identification

2.2.1 Production

The "Pentaflex® KB, Pentaflex® FTS, Pentaflex® OBS and Pentaflex® ABS and Pentaflex® Modul" construction products are produced industrially.

2.2.2 Packaging, transport and storage

The material shall be packed, transported and stored in compliance with the manufacturer's specifications. Care must be taken that the protective film is not damaged or removed prematurely.

¹ German committee for RC directive "Wasserundurchlässige Bauwerke aus Beton" (watertight structures made from concrete), December 2017

2.2.3 Identification of the product

2.2.3.1 Conformity mark (Ü mark)

The manufacturer shall mark the construction product with the conformity mark (Ü mark) in compliance with the conformity marking regulations of the federal states. This marking may be provided only if the conditions set forth in section 3 below are complied with.

The conformity mark with the required details:

- Name of manufacturer
- Number of the General Building Code Test Certificate (abP)

shall be provided on the packing or the package leaflet.

2.2.3.2 Additional details

The following additional details must be shown on the packaging of the construction product or in package leaflet:

- Product name
- Lot number
- Intended use
- Reference to application requirements

3 Declaration of conformity

3.1 General information

Confirmation that the above "Pentaflex® KB, Pentaflex® FTS, Pentaflex® OBS, Pentaflex® ABS and Pentaflex® Modul" steel plate waterstops are in conformity with the requirements set forth in the present General Building Code Test Certificate (abP) shall be provided for each production plant in the form of a manufacturer's declaration of conformity. This declaration shall be issued on the basis of factory production control (FPC) and on the basis of an initial type test for the product, which is performed by an approved inspection body.

3.2 Initial type test of the construction product performed by an approved inspection body

An initial type test is not required for the product, because the samples used for testing for purposes of a fitness-for-use attestation were taken from the normal production run in the production plant.

If the conditions under which the product is manufactured should change, an initial type test must again be made.

3.3 Factory production control (FPC)

DIN 18200 requires that factory production control (FPC) be established for, and be performed in the production plant.

Factory production control must be performed in compliance with the specifications shown in table 1, which reflect the special features of the products and the conditions for producing these products. The requirements made are based on the results of the initial type test.

The results of factory production control must be recorded and evaluated by the manufacturer. The records must include the following details as a minimum:

- Name of the product
- Type of test or inspection
- Date when produced and date of test
- Test results and comparison with requirements
- Signature of person in charge of factory production control

The records must be kept for a minimum of five years and must be presented upon request.

Should testing supply inadequate results, the manufacturer must take immediate action to remedy any deficiencies noted. Non-conforming construction products must be handled so that confusion with conforming and faultless construction products is positively prevented. Once the deficiency has been corrected, the required test must be repeated to the extent that is necessary to prove adequate correction.

Table 1: Type and frequency of tests to be performed as part of factory production control

Properties	Test conditions	Requirements	Intervals
Inspection of base material	Manufacturer's declaration or suitable tests	No signs of change	Per shipment lot
Plate thickness Coating thickness Height	- - -	0.60 mm \pm 10 % 0.30 mm \pm 10 % 167 mm \pm 10 % / 120 mm \pm 10 % / 80 mm \pm 10 % 60 mm \pm 10 %	Per lot or every 1000 m
Bond characteristics	Section 4.4.1 of the test principles	1.0 N/mm ² \pm 20 %	Per lot or every 1000 m
Weight per unit area	-	Height 167 mm= 920 g/m \pm 10 % Height 80 mm= 447 g/m \pm 10 % Height 60 mm= 335 g/m \pm 10 %	
Softening point	DIN EN 1427	104 °C \pm 10 %	
Needle penetration	DIN EN 1426	66 1/10 mm \pm 15 %	
Ash content	DIN 52005 (550 °C)	\leq 0.26 % (relative)	1 x per year

The records must be kept for a minimum of five years and must be presented upon request.

Should testing supply inadequate results, the manufacturer must take immediate action to remedy any deficiencies noted. Non-conforming construction products must be handled so that confusion with conforming and faultless construction products is positively prevented. Once the deficiency has been corrected, the required test must be repeated without delay to an extent that is technically feasible and necessary to prove adequate correction.

4 Execution

The steel plate waterstops "Pentaflex® KB, Pentaflex® FTS, Pentaflex® OBS and Pentaflex® ABS" are generally to be installed centrally in the construction joints or nominal crack cross-sections. The steel plate waterstops must be embedded in the concrete by at least 3 cm on each side. A minimum distance of 5 cm or at least three times the size of the largest grain to the edge of the component must be maintained. The fastening is done with the corresponding variable holding modules on or at the reinforcement. It must be checked that no shifting or floating is possible during the concrete layers. The joint areas are overlapped by > 5 cm and pressed firmly together after removing the protective film. Finally, the areas are secured with the corresponding butt clips.

The PENTAFLEX® Modul is first fixed to the formwork in conjunction with the FERBOX ® backbend connectors. After concreting the 1st section, the sheet metal shell and the EPP filler strips are removed and the sheet metal is checked for integrity and correct fit. The connection mix may have a maximum maximum grain size of 8 mm.

The protective films must be removed shortly before the concrete is placed.

The DBV data sheet "Coated metal waterstops", version March 2023 and the manufacturer's instructions (Annexes 1 to 17) also apply to the execution and installation work.

5 Legal basis

This General Building Code Test Certificate (abP) is issued on the basis of article 19 of the building code of Lower Saxony (NBauO) in conjunction with Verwaltungsvorschrift Technische Baubestimmungen No. C 3.30.

6 Legal remedy

This General Building Code Test Certificate (abP) is subject to objection. Objections must be lodged in writing or stated orally on the record of the management of Materialprüfanstalt für das Bauwesen, Beethovenstraße 52, 38106 Braunschweig within a period of one month after it has been issued. The date on which the Testing Laboratory receives the notice of objection shall decide on whether the objection was made timely.

i. A.

Dipl.-Min. F. Ehrenberg
Head of Testing Laboratory

M. Pankalla
Engineer/official in charge

Manufacturer's Installation Instructions

Installation instructions: Pentaflex KB 16.7 and KB 12

Construction joint: Floor/wall

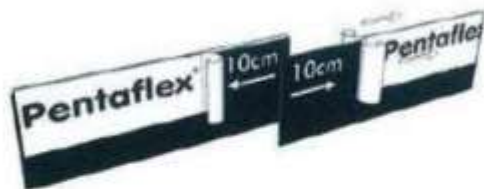
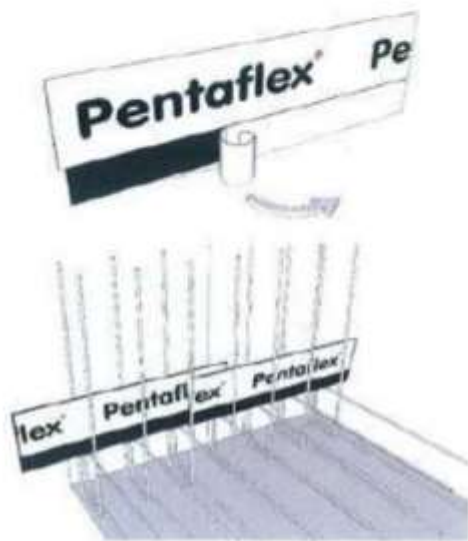

- 1 Remove the film from the underside (The overlapping strip must be on the bottom)
- 2 Distribute (place) the elements in the vertically-rising reinforcement.
- 3 Peel back the film approx. 10 cm in the end areas.
- 4 Overlap the elements by at least 5 cm and bond together by pressing them firmly together. For temperatures below 5°C, warm the joints gently with a small blow-lamp.

Installation instructions: Pentaflex KB 16.7 and KB 12

Construction joint: Floor/wall

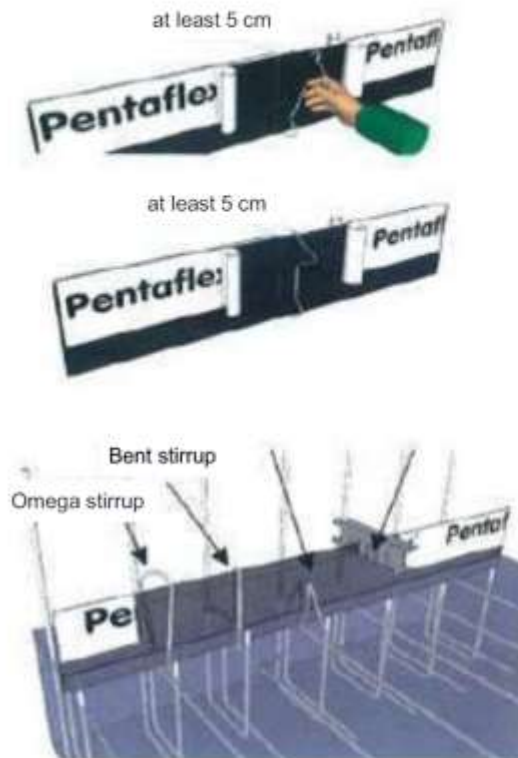

- 5 Attach a thrust retaining element to each joint. Hook the joint clip onto the underside first.

As additional security, peel back the film strip over the connection again and press down.

- 6 The elements are now fixed by installing retention stirrups with a spacing of 1 metre

There is a choice of 4 types of stirrup for this. Please select these from our brochure

If the application is the wall/bottom joint of prefabricated walls, we recommend 2 retention stirrups per metre, to ensure the necessary alignment.

Attachment accessories:

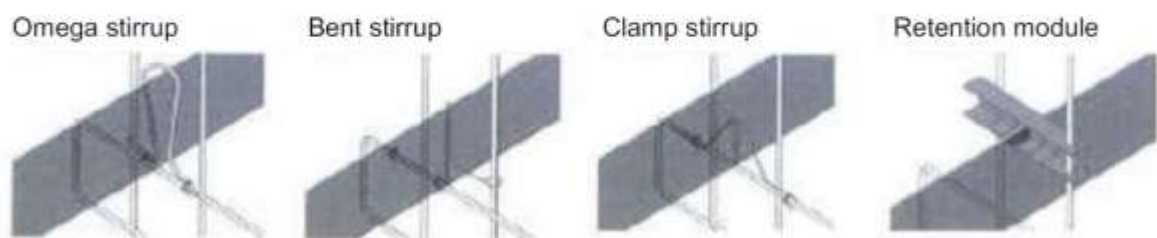

Installation instructions: Pentaflex KB 16.7 and KB 12

Construction joint: Floor/floor, ceiling/ceiling and wall/wall

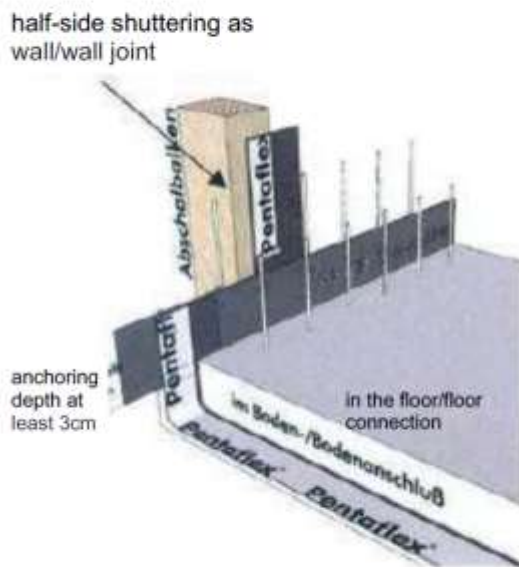

- 7 The upper film should only be peeled back once the first element has been concreted, so that the coating doesn't get dirty. This is important since the dirt may create leak points.
- 8 T joints and cross-points should be secured on both sides using the brackets supplied. Each crate contains 50 thrust clips and 8 cross clips.
- 9 Note: During concreting of the floor/floor joint, particular care must be taken with the free-cavity sealing in the area under the coated joint element!
- 10 Before concreting the second section remove the protective films from the KB element.

Butt joints:

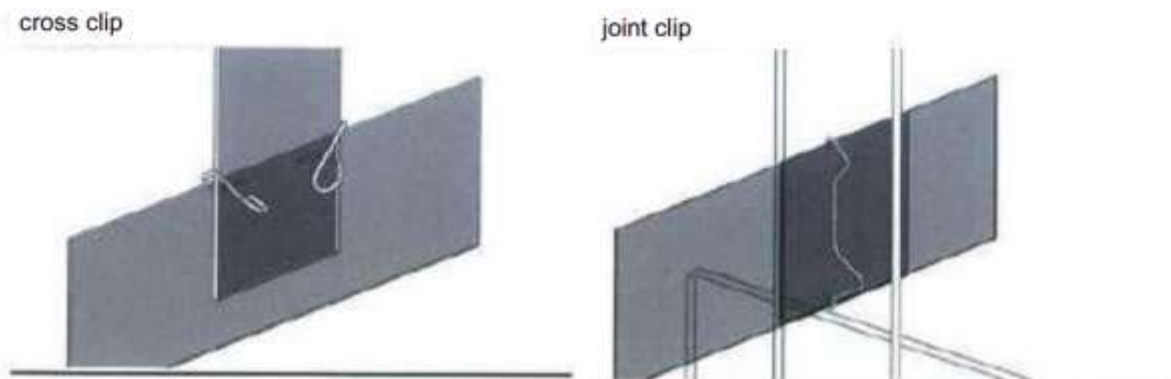

Installation instructions: Pentaflex KB 8

Construction joint: Wall/ceiling

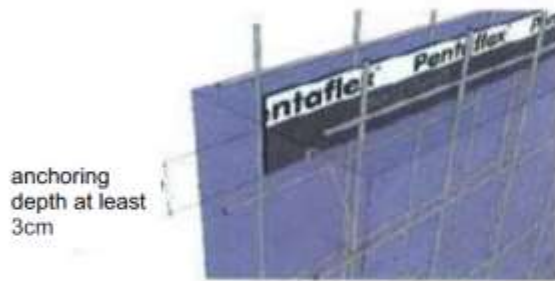
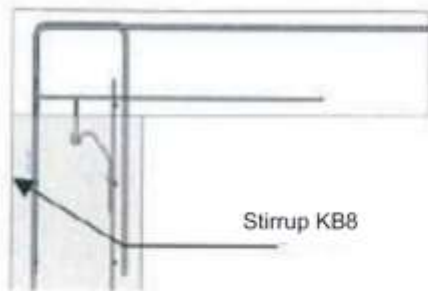

- 1 Fasten the retention stirrup KB8 (approx. 2 pieces per metre) onto the vertically-rising wall reinforcement. If the retention stirrups are being inserted into prefabricated walls they must be attached to the grid supports such that one PENTAFLEX KB8 element is held by at least 2 stirrups.

- 2 Remove the film from the underside of the PENTAFLEX KB8 elements.

- 3 Distribute the elements and suspend them in the retention stirrups.

Installation instructions: Pentaflex KB 8

Construction joint: Wall/ceiling

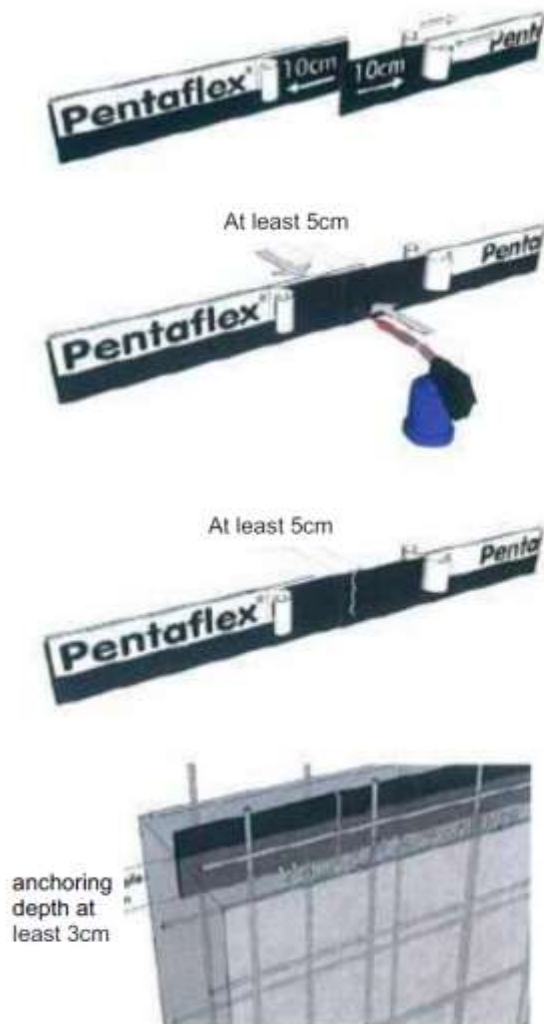

- ④ Peel back the film at the ends by approx. 10 cm.
- ⑤ Overlap the elements by at least 5 cm and press them firmly together to make the connection. If the temperature is below 5°C, heat the butt surfaces with a blowlamp or gas torch.
- ⑥ Create a thrust retaining element at each connection point using "joint clips 80". Roll the film strips back over the connection and press them on to provide additional protection.
- ⑦ When concreting ensure that the KB 8 is anchored at least 3 cm into the wall concrete.
- ⑧ Do not remove the upper film until concreting of the wall is completed.

Installation instructions: Pentaflex KB 8

Construction joint: Wall/ceiling

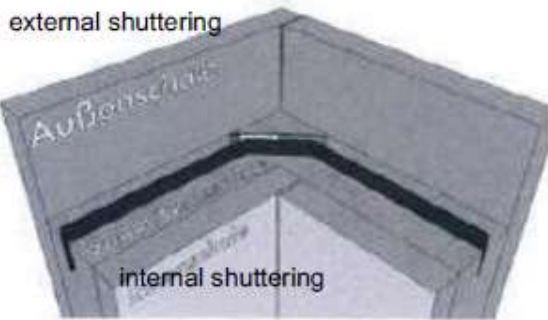

- 9 Corner construction: Corners and angles can be produced by appropriate bending of the KB 16.7 or KB 8.

- 10 T joints, connections or height offsets are produced by making connections as described in point 5.

To be observed when using prefabricated walls



- 10 Pentaflex KB-corner 16.7 and 8 are also supplied as mouldings.

Status: 09.07.2009

We reserve the right to make technical changes to our products that do not affect our test principles and the "ABP".

Installation instructions: Pentaflex FTS

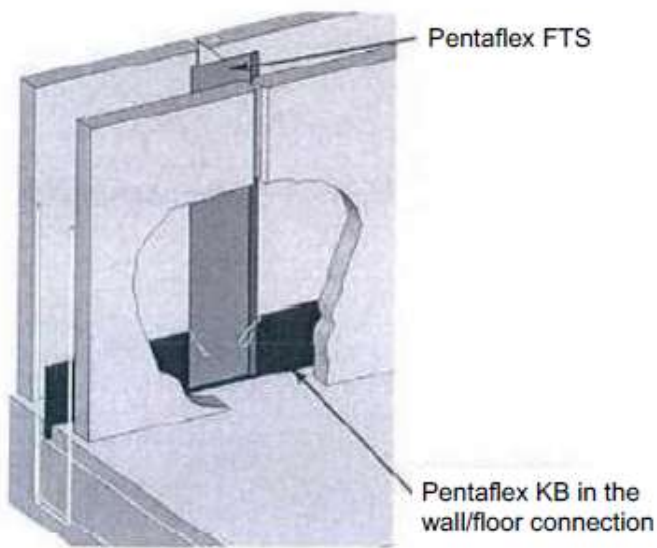

Plan view
Pentaflex FTS

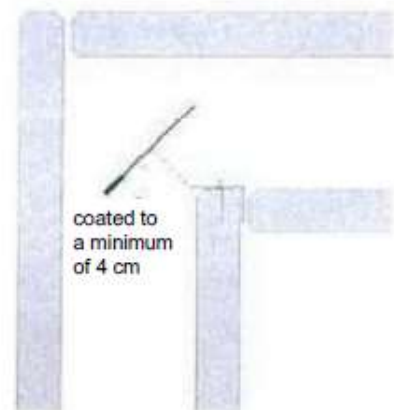
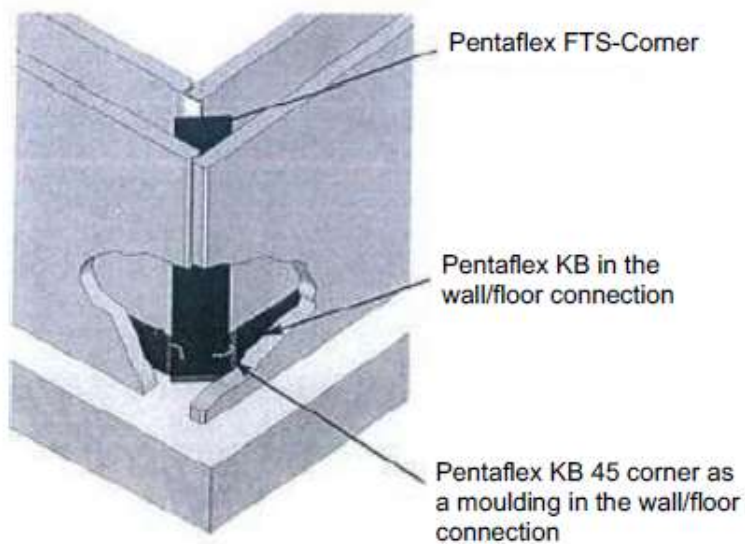
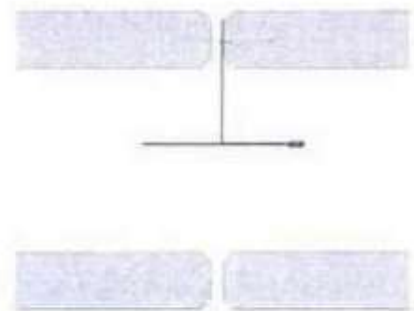

Installation instructions: Pentaflex FTS

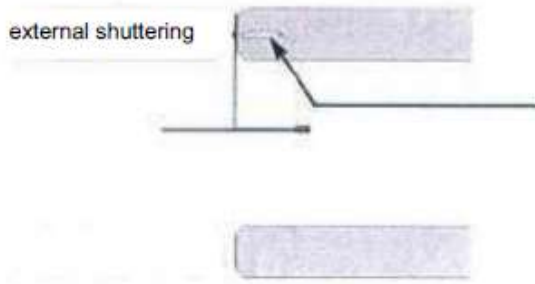

- 1 Remove the protective films from the Pentaflex sealing plate
- 2 Fix the uncoated wing to the face side (as a rule – external shuttering) using shear dowels.
- 3 Connect the coated sealing element with the Pentaflex KB to the floor slab, min. 5 cm overlap and fix the butt using cross clips! If the temperature is below 10°C, heat up.

Assembly of FTS-corner elements

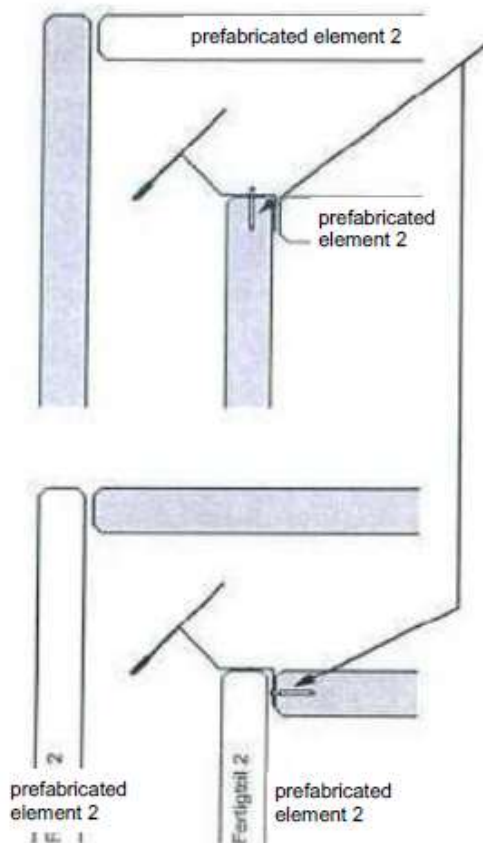

- 4 When installing the prefabricated break-off FTS-corner please note:
The break-off element has a different connection to the face side of the inside shell of the first prefabricated element to be positioned (prefabrication element 1) depending on the direction of assembly.

Pentaflex FTS – assembly sequence

- 1 Determine the direction of assembly for the prefabricated elements.
- 2 When placing the first wall element, the Pentaflex prefabricated break-off elements are fixed to both face sides of the prefabrication and connected to the floor slab using the Pentaflex KB.
- 3 Relative to the direction of assembly, a Pentaflex FTS element is attached in each case to the free end of the newly-positioned prefabrication and connected to the floor slab using the Pentaflex KB.

Example:

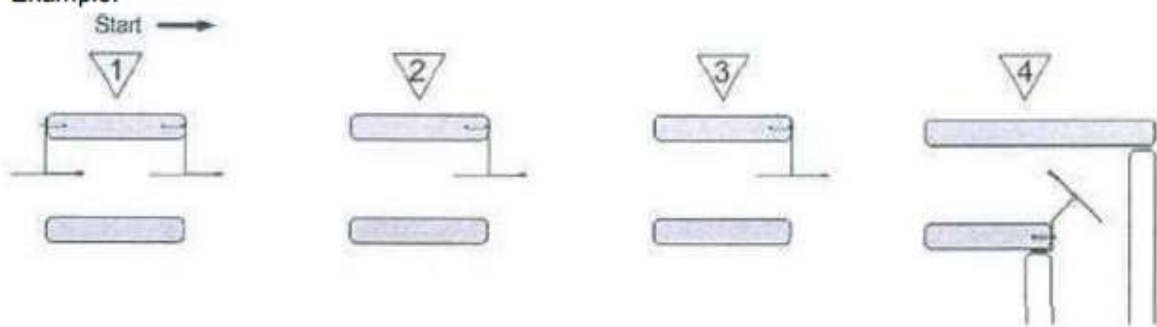

- 4 The last wall element is lowered vertically between the prefabricated parts already provided with Pentaflex FTS and it is then attached:

Example:

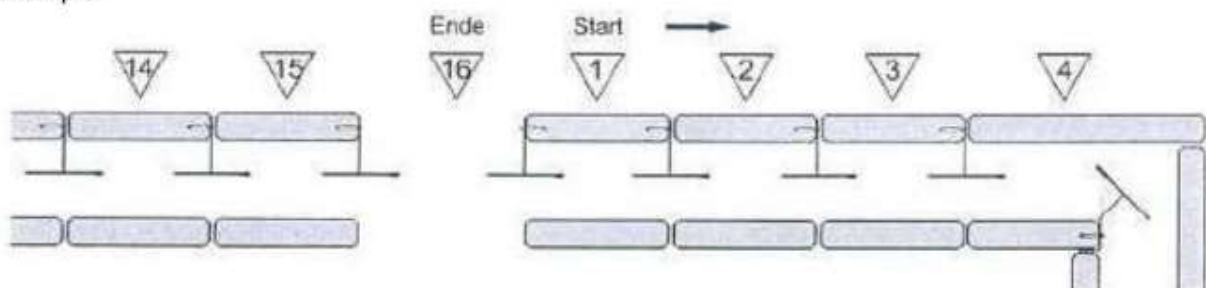

Status: 09.2009

We reserve the right to make technical changes to our products that do not affect our test principles and the "ABP".

Installation instructions: Pentaflex OBS

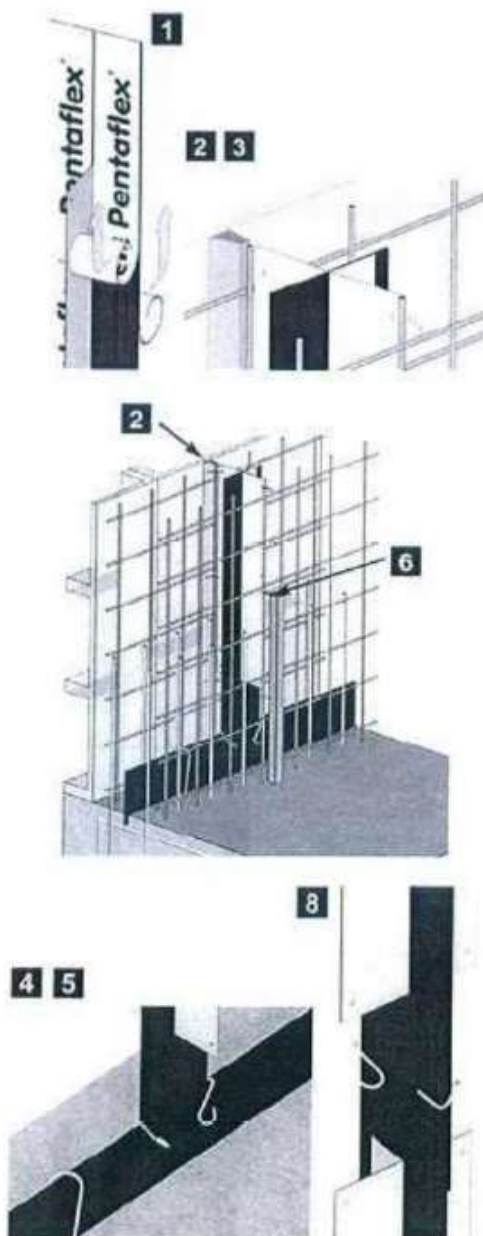

- ❶ Remove the protective films from the Pentaflex OBS.
- ❷ Install a trapezoidal strip into the shuttering where the break-off should be created (plane of the assembly plate)
- ❸ Position the OBS element in the wall shuttering between the outer and inner reinforcement layer. It is secured using tie-wire. This is guided through the existing holes in the assembly plates and lashed securely to the reinforcement. The OBS element must be fixed such that the assembly plate lies in the plane of the planned break-off position; the sealing level is then parallel to the shuttering surface and lies in the axis of sealing of the floor/wall joint (Pentaflex KB).
- ❹ Connection of the OBS element to the KB is made by making a 5 cm (minimum) overlap and firmly pressing them together. If the temperature is below + 5°C, heat the connection area.
- ❺ Each connection point must be secured using 2 cross clips.
- ❻ Before closing the wall shuttering, a trapezoidal strip must also be placed in the axis of the assembly plate of the OBS element.
- ❼ During concreting take care that the OBS element is not subjected to one-sided pressure from the concrete. The pouring height must be kept at the same level on both sides.
- ❽ Joints and attachments must be manufactured and secured by connections as described in points 4 and 5 above.

Status: 09.2009

We reserve the right to make technical changes to our products that do not affect our test principles and the "ABP".

Installation instructions: Pentaflex ABS

Construction joint: Floor/floor

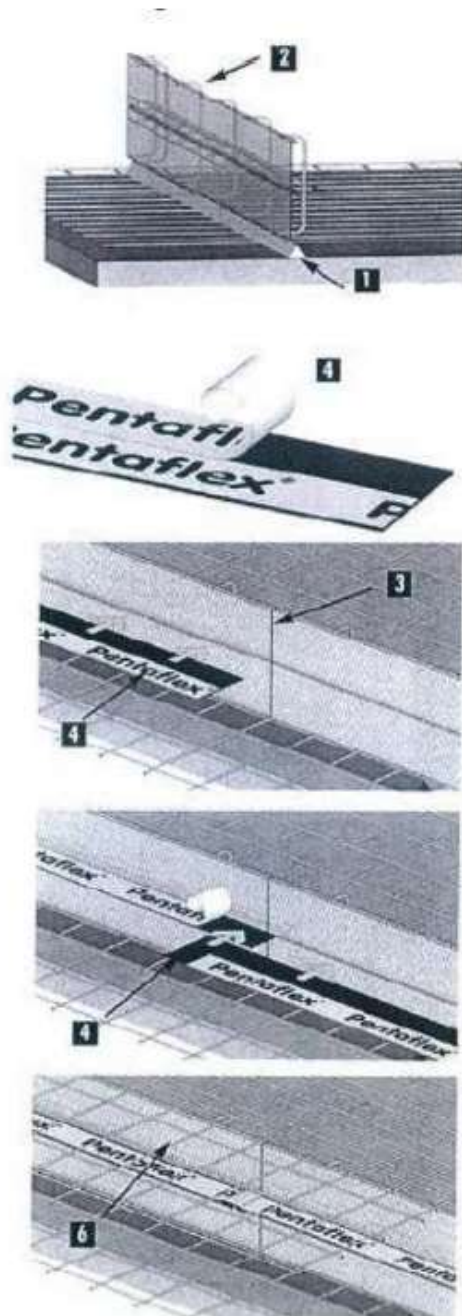

- 1 Install a suitable distance piece, size nom c, into the blinding layer/shuttering at the location where the construction joint should be positioned (plane of the expanded metal sheet).
- 2 Installation of the ABS elements on the lower reinforcement layer. The direction of installation must be selected such that the formwork girder protrudes into the first concreting section. Tie-wire is used to attach it to the lower reinforcement. Optionally, the element can also be welded to the reinforcement.
- 3 The ABS elements are extended by butting two formworks.
- 4 Peel off the film on one side of the Pentaflex KB above and below and insert into the formwork up to the stop position. The seam joint clips should overlap by 5 cm.
- 5 The connection of the ABS element to the KB for the floor slab/wall joint is made using a corner addition. Connection is made by creating an overlap of at least 5 cm and pressing them firmly together. If the temperature is below +5°C, warm the connection area and secure with a cross clip.
- 6 Install the upper reinforcement and shutter the upper concrete cover. Connect the ABS element with the upper reinforcement using tie-wire. Optionally, the element can also be welded to the reinforcement.
- 7 The protective films should be removed from the upper and lower side of the seam joint before concreting the second section.

Cross-section of the installation situation

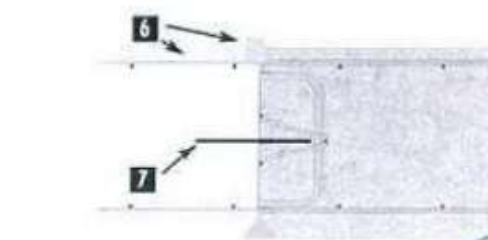

Installation instructions: Pentaflex ABS

Construction joint: Wall/wall

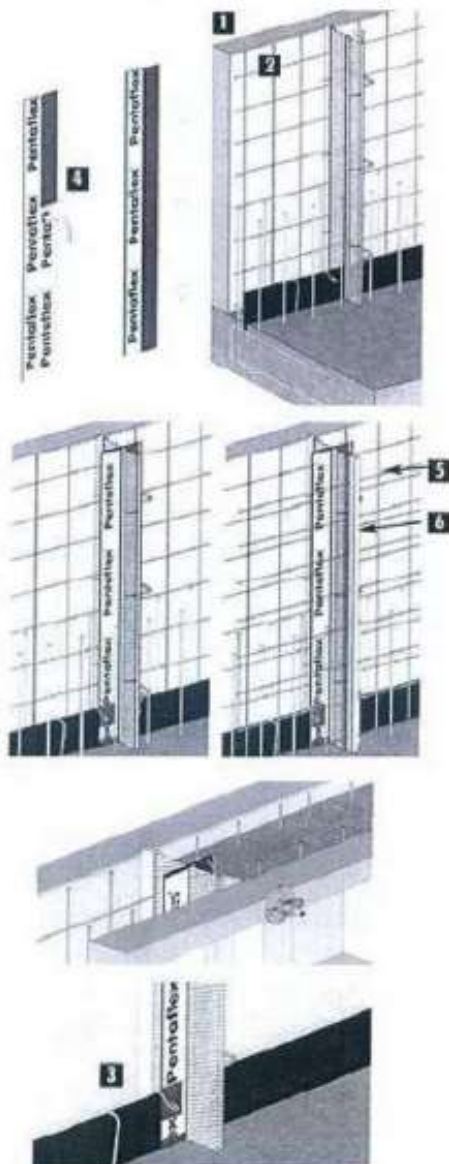

- 1 Place the external shuttering and attach a trapezoidal strip to the construction joint.
- 2 Insert the external reinforcement and bind to the connection reinforcement. Optionally, the element can also be welded to the reinforcement. Use a suitable water-impermeable distance piece.
- 3 Place the ABS element with the slotted side over the Pentaflex KB for the floor/wall joint and tie together with the external reinforcement in the desired position.
- 4 Pull off the external and internal protective paper from the Pentaflex KB and insert in the formwork up to the stop position. The seam joints should overlap by 5 cm and be pressed together. If the temperature is below +5°C, warm the connection area and secure with a cross clip.
- 5 Position the internal reinforcement and bind to the ABS element (tie-wire, welding).
- 6 Fix a trapezoidal strip to the internal formwork and close it. Use suitable water-impermeable tie points.
- 7 The remaining protective film should be removed from the Pentaflex KB before shuttering the second concrete section.
- 8 Joints and attachments must be manufactured and secured by connections as described in point 4.



Status: 09.2009

We reserve the right to make technical changes to our products that do not affect our test principles and the "ABP".

Installation instructions: Pentaflex ABS with prefabricated walls

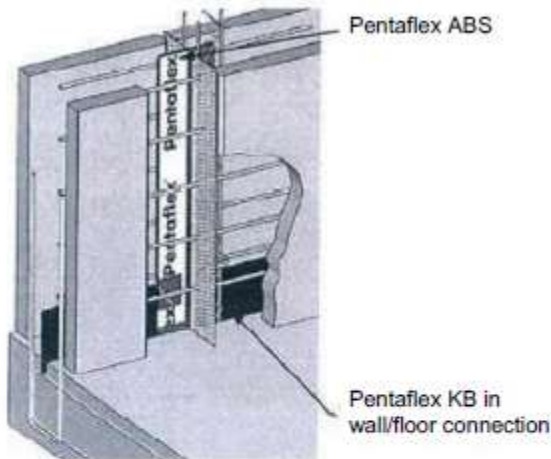

Plan view
Pentaflex ABS

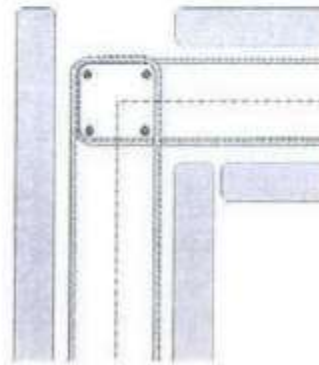
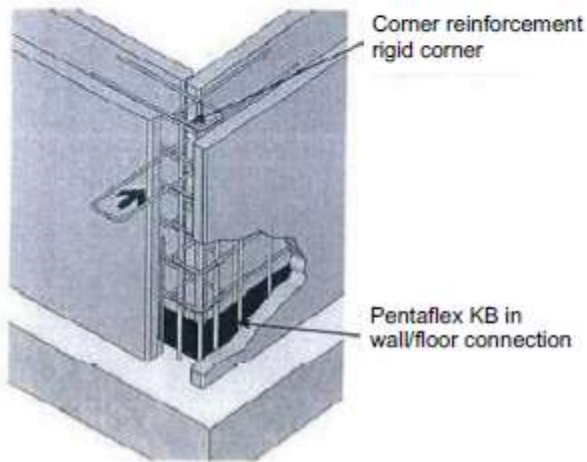
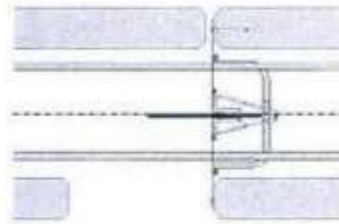

Pentaflex ABS – Assembly sequence for prefabricated walls

- 1 Specification of the assembly direction for the prefabricated elements.
- 2 When placing the first wall element the Pentaflex ABS is attached to the face sides of the prefabricated part and tied into the floor slab using the Pentaflex KB.
- 3 In accordance with the assembly direction, a Pentaflex ABS element is attached to each free end of the newly erected prefabricated part and tied into the floor slab using the Pentaflex KB.

Example:



- 4 The last wall element is lowered vertically between the prefabricated parts that already have the Pentaflex ABS and it is then assembled:

Example:

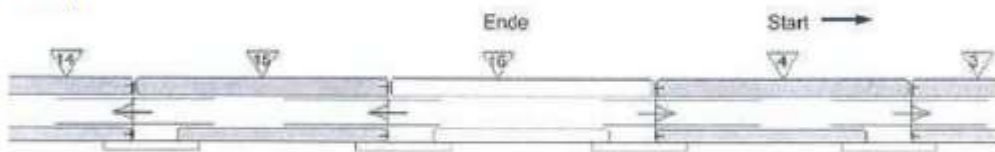

Status: 09.2009

We reserve the right to make technical changes to our products that do not affect our test principles and the "ABP".

Installation instructions: Pentaflex ABS with prefabricated walls

Construction joint: Wall/wall

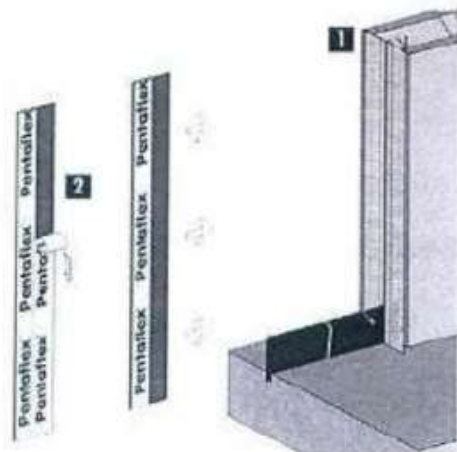

- 1 Position the first wall element and place the ABS element with the slotted side over the Pentaflex KB for the bottom/wall joint and attach to the face sides of the prefabricated formwork using shear dowels.



- 2 Pull off the external and internal protective paper from the Pentaflex KB and insert in the formwork up to the stop position. The seam joints should overlap by 5 cm and be pressed together. If the temperature is below +5°C, warm the connection area and secure with a cross clip.



- 3 Push the supplementary reinforcement through the meshed-metal grid (drill, hammer through) until it protrudes approx. 30 cm.

- 4 Before positioning the next wall element, remove the remaining protective film from the Pentaflex KB.

- 5 Position the next wall element and proceed as for points 1-4.

- 6 Pull the supplementary reinforcement through the access opening and centre it on the ABS element (optionally attach to the mesh supports with tie-wire).

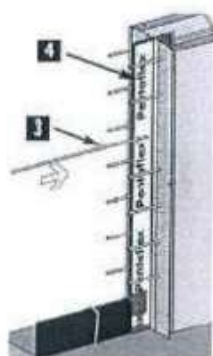

- 7 Shutter the access opening before concreting.

- 8 Joints and connectors must be manufactured and secured by connections as described in point 2.

Installation instructions: PENTAFLEX Modul

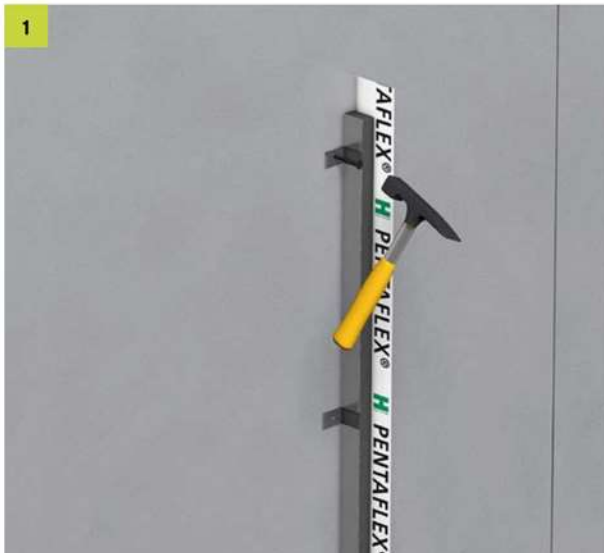

1 Nail the PENTAFLEX® module to the formwork using the nailing lugs.

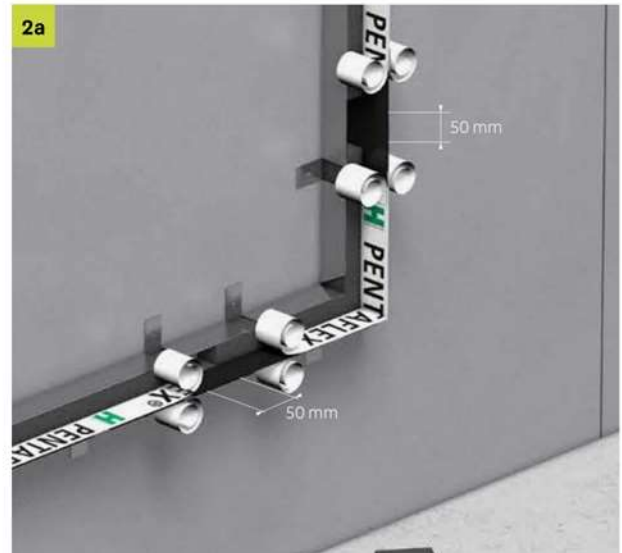

2a Connecting the corner module with two PENTAFLEX® modules
Remove the protective film,
overlap the sheets by at least 50 mm.

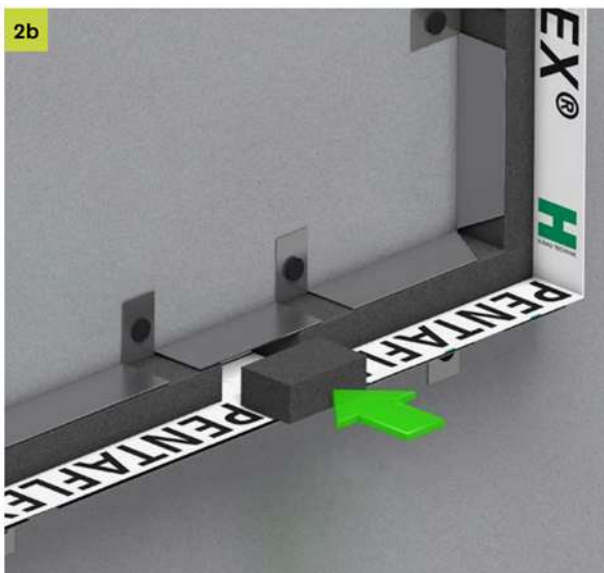

2b Fill empty spaces with EPP plugs

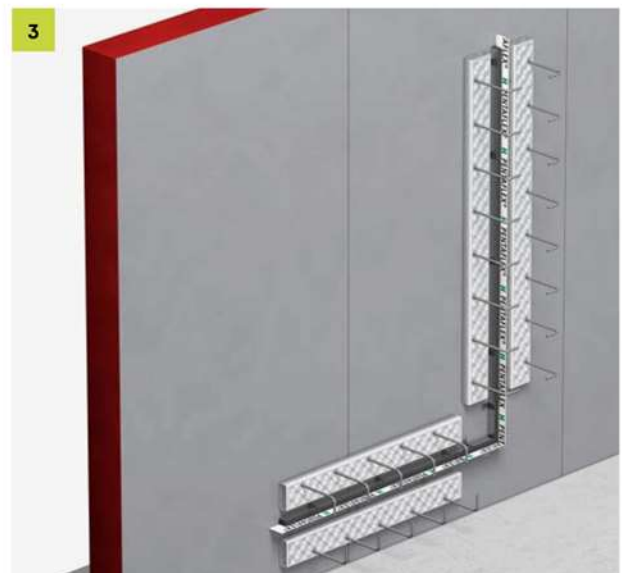

3 Next to the PENTAFLEX® module, nail two single-row FERBOX® backband terminations to the formwork.

Installation instruction: PENTAFLEX Modul

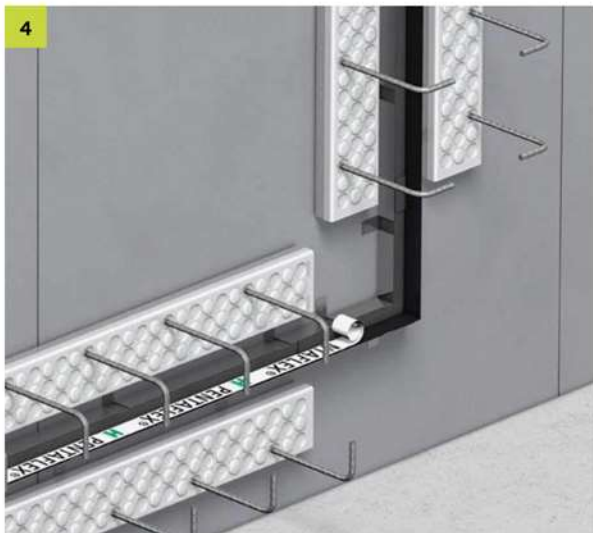

Remove the protective film from the PENTAFLEX® metal water stop before concreting.

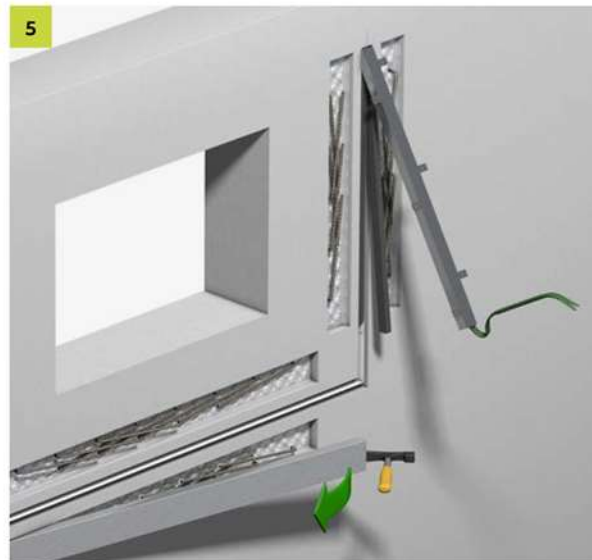

After the first concreting section, remove the storage boxes of the FERBOX® backend terminations, the shells of the PENTAFLEX® modules as well as the EPP strips.

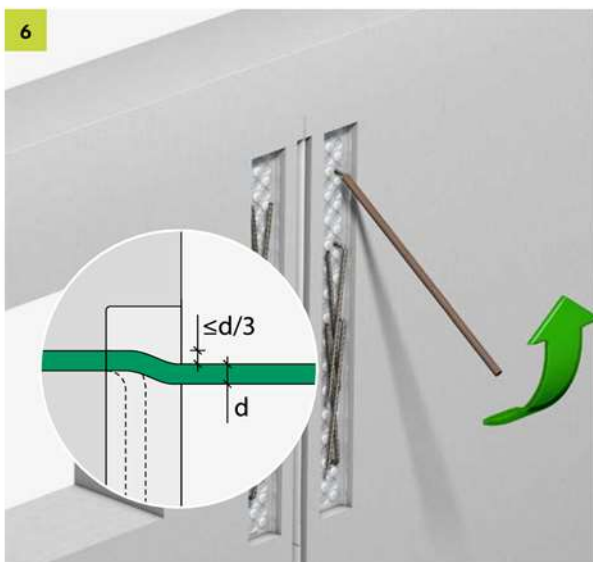

Bend back the reinforcement bars of the FERBOX® rebend connections with a suitable tool.

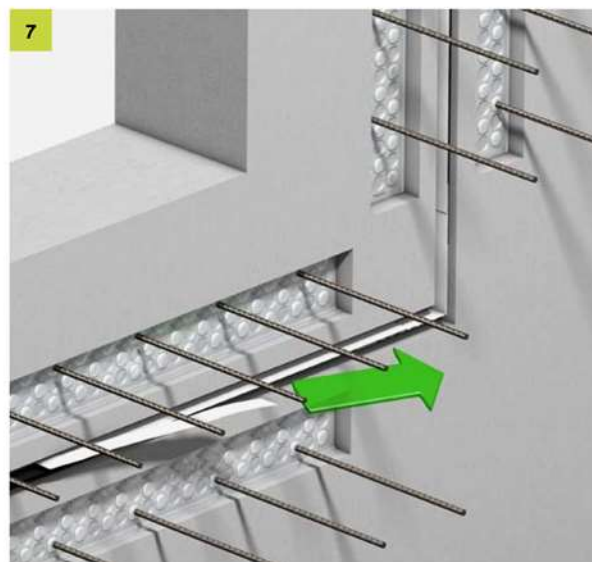

Peel off the second half of the protective film from the PENTAFLEX® metal waterstop. Then form and pour the second concreting section.