

# Mesh cable trays

Technical information

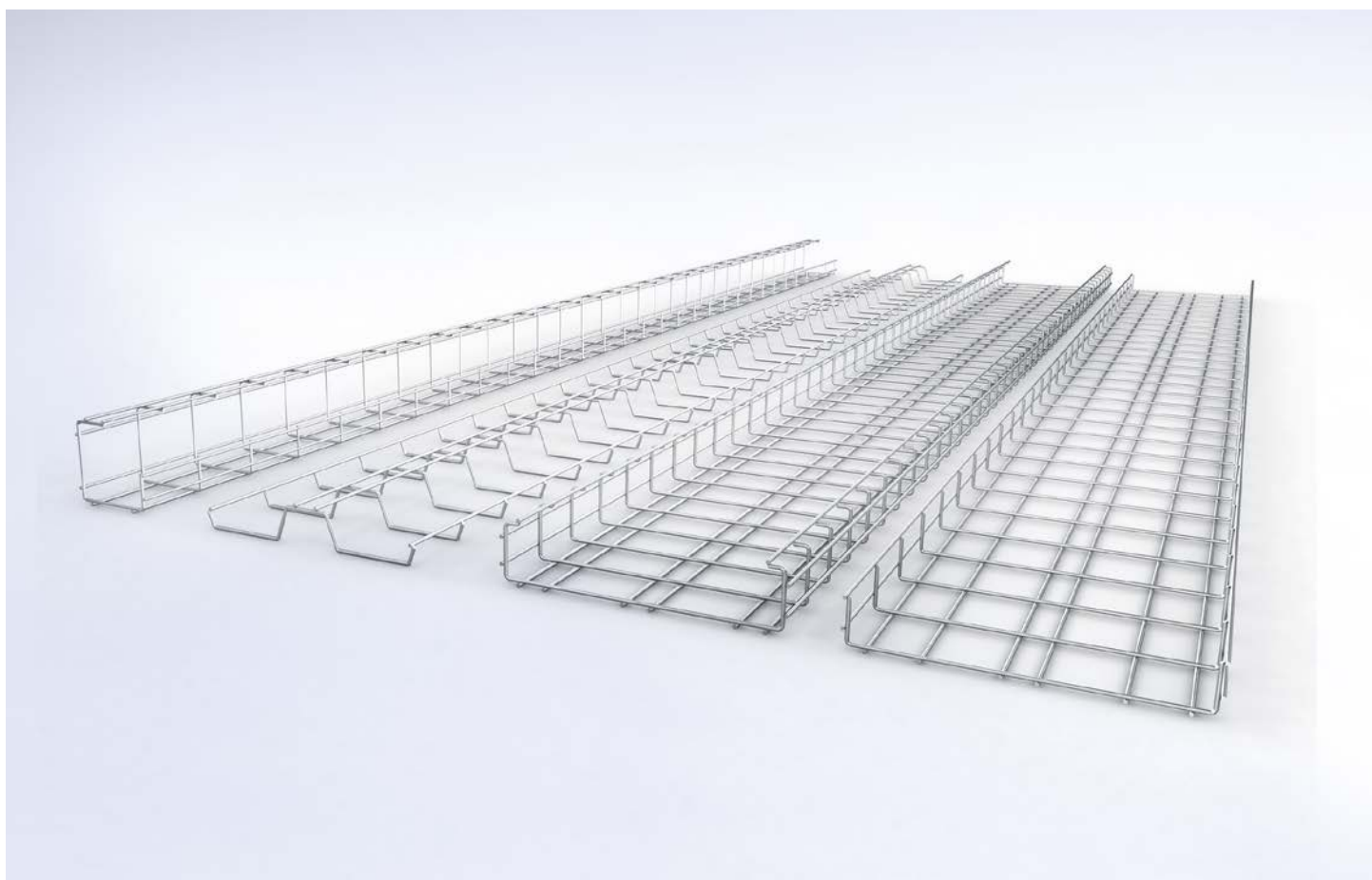



# Table of contents

## Mesh cable trays

---

Product description	5
System overview	6
Mesh cable tray G 50	8
Mesh cable tray G 100	11
Mesh cable tray GI	14
Mesh cable tray GTDW	17
Mesh cable tray GTD 30	19
Covers and installation components	22

## Further information

---

Planning advices	24
Application examples	34

## Service

---

Our synergy concept for your benefit	44
--------------------------------------	----

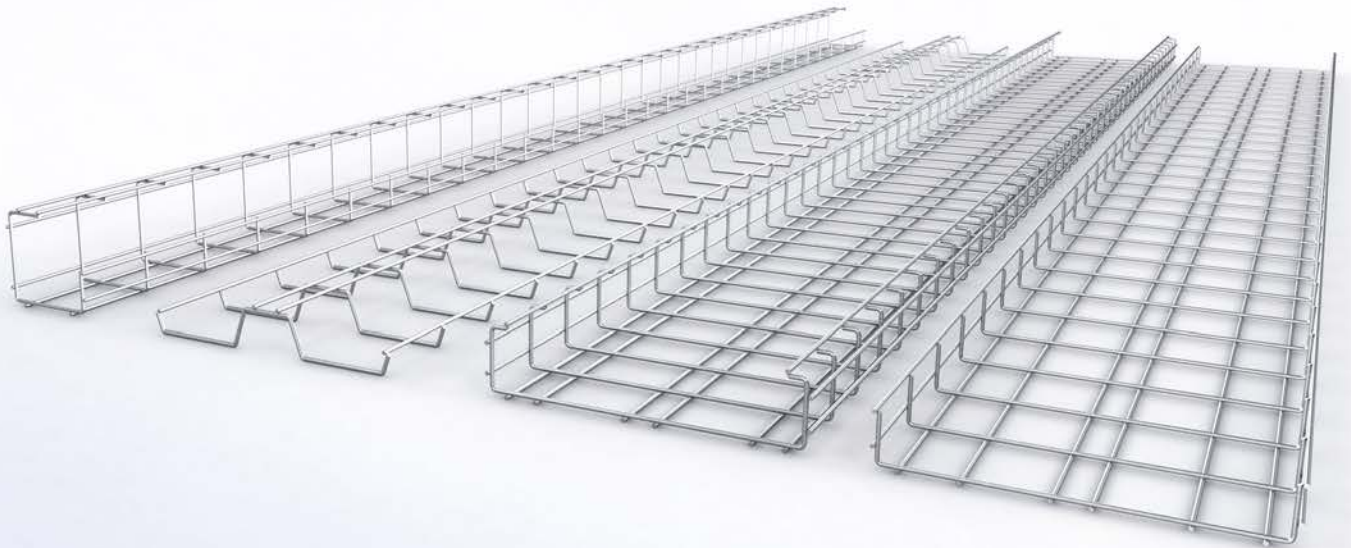

# Mesh cable trays

## Product description

Our mesh cable trays are ideal for routing cables horizontally in hygienic areas, datacentres or in the machine building industry. Their ability to reduce the risk of heat build-up is just one advantage of their open design. In addition, the cables remain easily visible and can be fed in and out at any point in a flexible way. Dirt and moisture find it virtually impossible to gain a foothold.

When it comes to the most commonplace applications, the standard range has got it all covered. For instance, the mesh cable trays are available in U, C, G or W-shaped versions and with a variety of heights including 30, 53, 60 or 103 mm. Special sizes can also be produced on request. We offer various materials and surface finishes to ensure that the corrosion protection requirements are met for all sorts of application areas.

The mesh cable trays can be installed on walls, ceilings or roofs – either directly or by using a profile rail. They are equally suitable for routing cables in raised floors.

To round off the system, our range also includes matching covers and essential accessories.



## Benefits

- Compatible with virtually all cable types and diameters
- Cables can be fed out in any direction and at any time
- Very little surface area for dirt and moisture to cling to
- Open design allows cables to cool
- Efficient installation with simple hand tools
- Suitable for indoor and outdoor locations, and for use in the chemicals and food industries
- Customisable on request, e.g.: double thickness zinc coating or alternative colours

## Areas of application



**On walls and ceilings in the context of technical building equipment – indoors and outdoors**



**Hygienic areas, such as those encountered in the chemicals and food industries: stainless steel version (V2A)**



**Server rooms, computer centres and data centres**



**Tunnels: stainless steel version (V4A)**

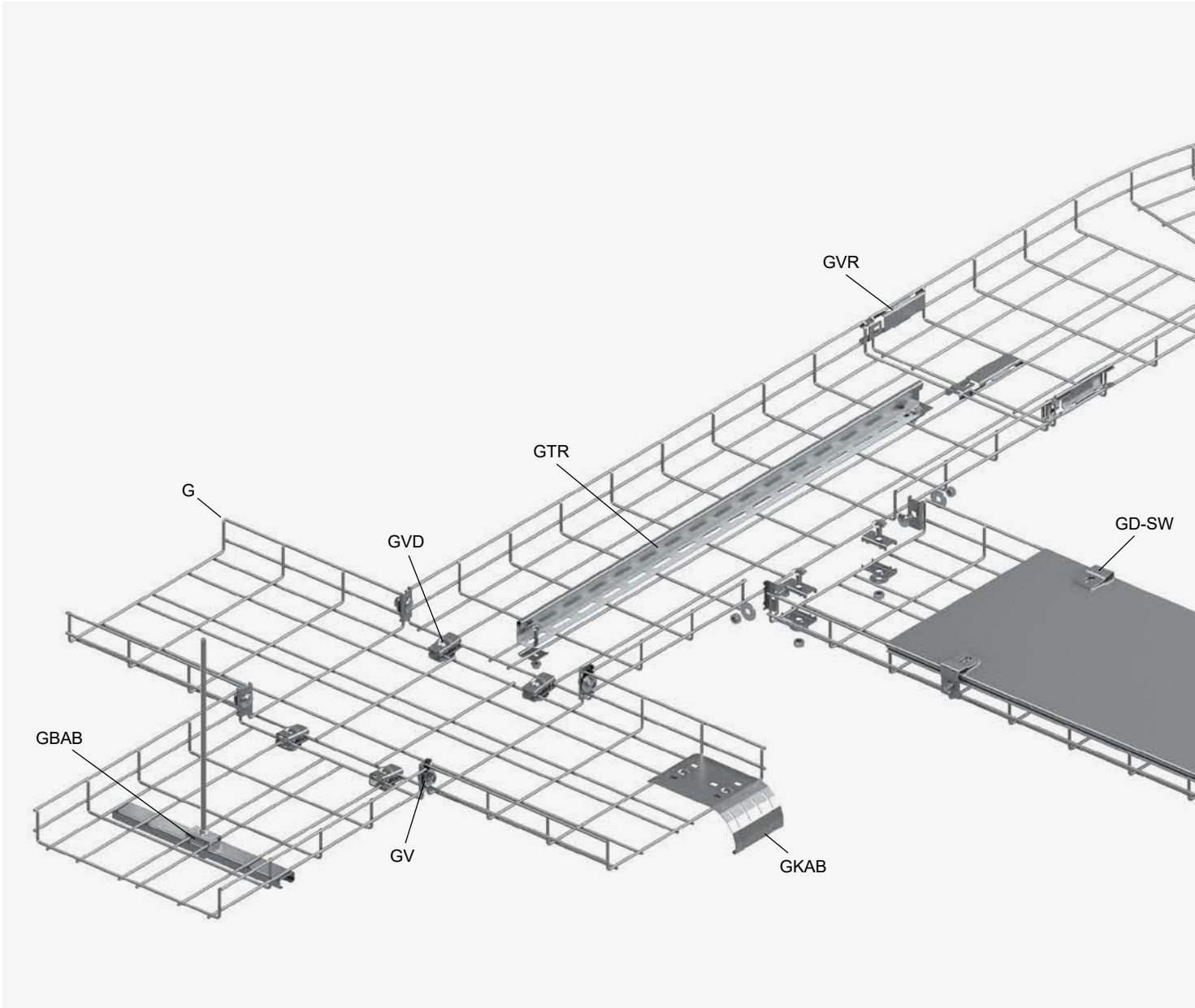

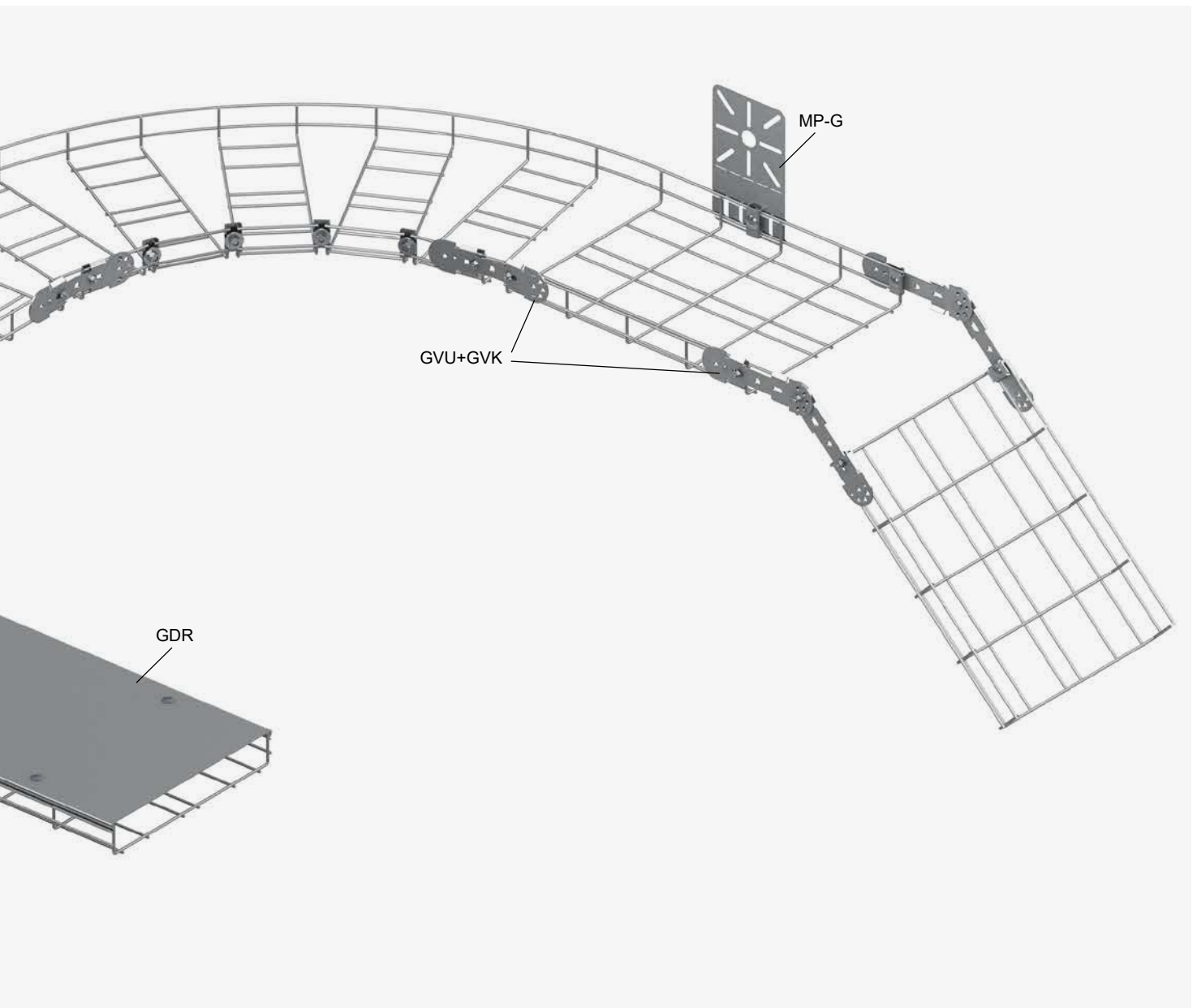

## System overview

Mesh cable trays enable you to route cables in a neat and well-organised manner. Thanks to the open design, cables and lines can be fed in and out at any point and at any time. Mesh cable trays can be combined with the matching covers and appropriate fastenings to create a complete cable management system with a high level of flexibility. The mesh cable tray connectors (GV 30, GVD) and universal connectors (GVU), allow the mesh cable trays to be assembled quickly and easily in a straight line.

Even horizontal changes in direction can be achieved with ease, e.g. by using clamps (GVK). The optional matching covers (GD) can be purchased for extra protection against contact or dirt.

# G 50

## U-shaped mesh cable tray

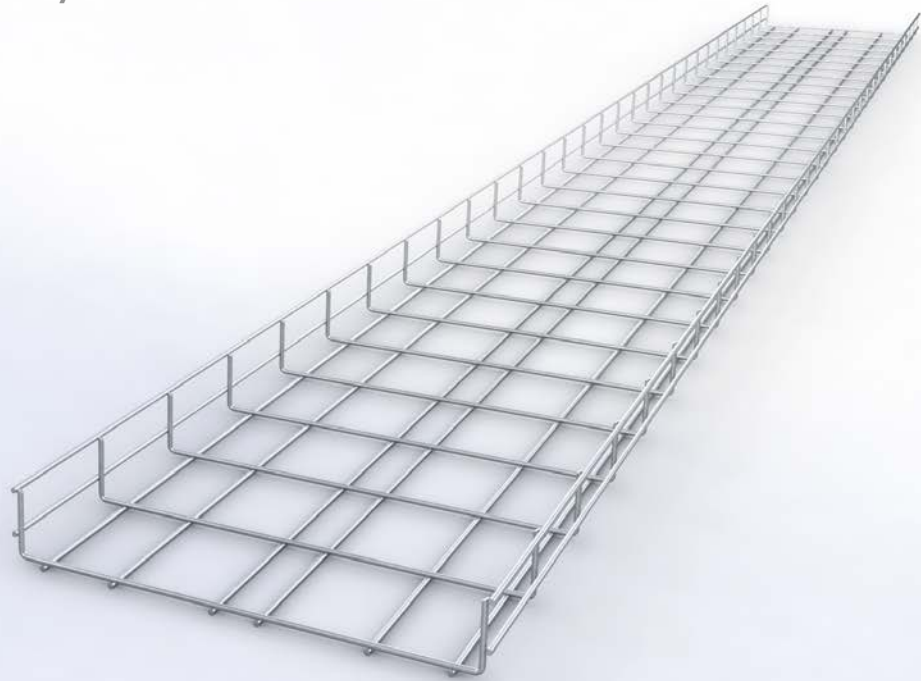

### Product features

- Height of sides: 53 mm
- Available tray widths: 76 to 618 mm
- Length: 3,000 mm
- Cross-sectional areas of 25 to 264 cm<sup>2</sup>
- Design: U-shaped



For information on how to assemble mesh cable trays with changes of direction, please see our associated assembly instructions, which are available at [www.pohlcon.com](http://www.pohlcon.com).

### Available surface coatings and materials

- GV** Zinc-plated in accordance with DIN EN ISO 2081
- S** Pre-galvanised wire in accordance with DIN EN 10244-2
- F** Hot-dip galvanised in accordance with DIN EN ISO 1461
- E** Stainless steel, material no. 1.4301 (V2A)
- E4** Stainless steel, material no. 1.4571/1.4404 (V4A)

## Technical data

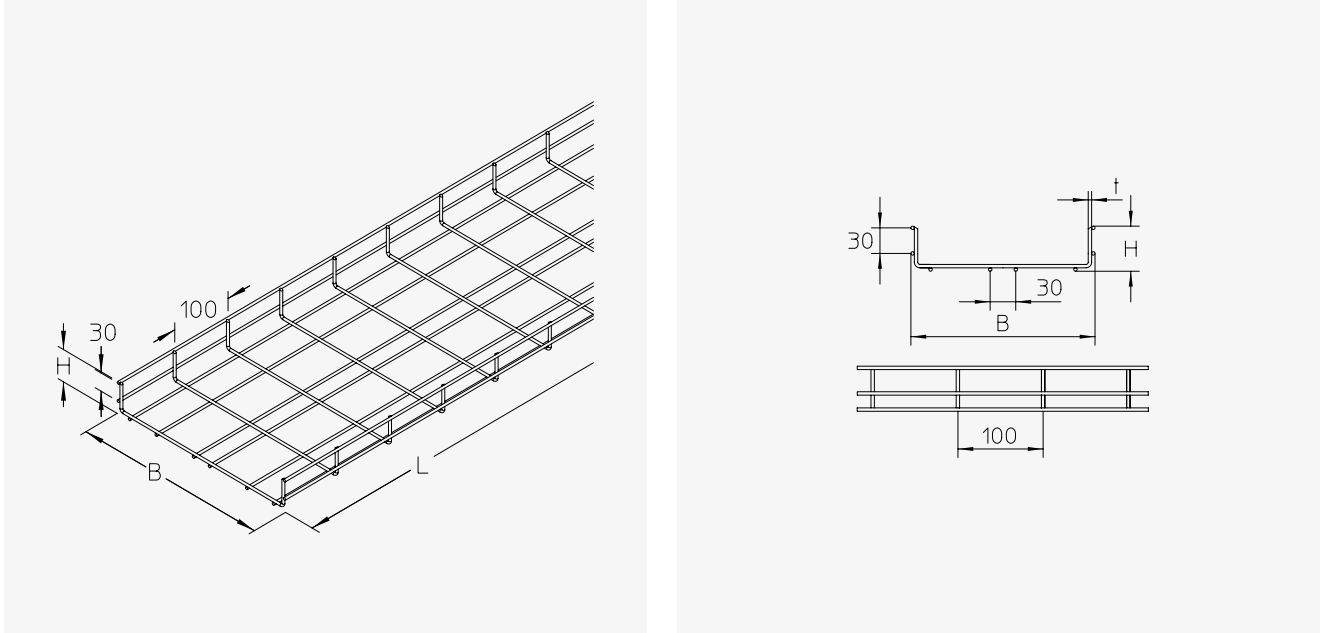

Model	H mm	B mm	L mm	t mm	A cm <sup>2</sup>	Q <sub>SK</sub> kN/m	G <sub>GV</sub> kg	G <sub>S</sub> kg	G <sub>F</sub> kg	G <sub>E</sub> kg	G <sub>E4</sub> kg
G 50-06	53	76	3,000	4.0	25	0.04	2.26	2.26	2.41	2.26	2.30
G 50-10	53	116	3,000	4.0	45	0.07	2.38	2.38	2.55	2.38	2.43
G 50-20	53	216	3,000	4.0	90	0.14	3.28	3.28	3.51	3.28	3.35
G 50-30	53	316	3,000	4.0	135	0.20	4.18	4.18	4.48	4.18	4.27
G 50-40	53	418	3,000	4.5	176	0.26	6.42	6.42	6.87	6.47	6.53
G 50-50	53	518	3,000	4.5	220	0.33	7.56	7.56	8.09	7.62	7.68
G 50-60	53	618	3,000	4.5	264	0.40	8.70	8.70	9.31	8.77	8.84

H: Height | B: Width | L: Length | t: Material thickness | A: Cross-sectional area | Q<sub>SK</sub>: Control cable distributed load | G: Weight (per surface)



Example order  
Model/version: G 50-10S

# Load diagram

## G 50 S F E

$Q_{max}$  [kN/m]

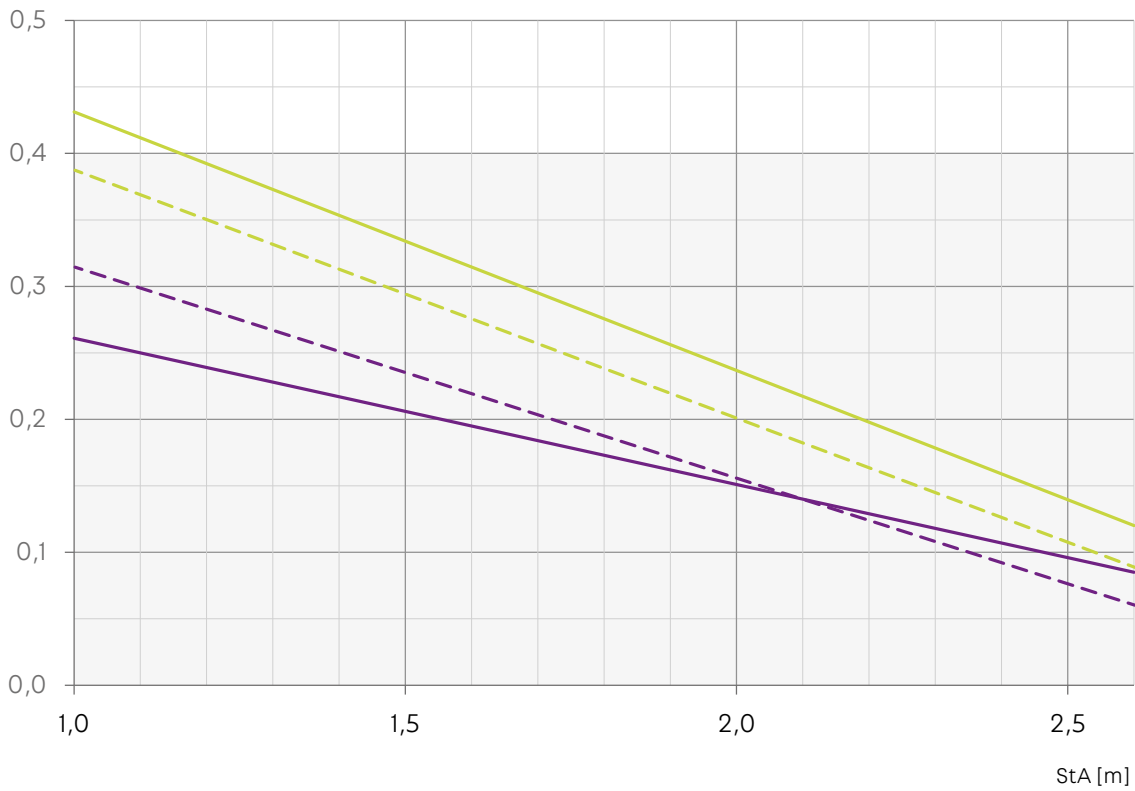

- Tray width: 100 to 300 mm in **S** **F**
- Tray width: 100 to 300 mm in **E**
- Tray width: 400 to 600 mm in **S** **F**
- Tray width: 400 to 600 mm in **E**

 Filled to capacity with maximum tray width

$Q_{max}$ : Max. distributed load

StA: Support distance



UL classified

# G 100

## U-shaped mesh cable tray

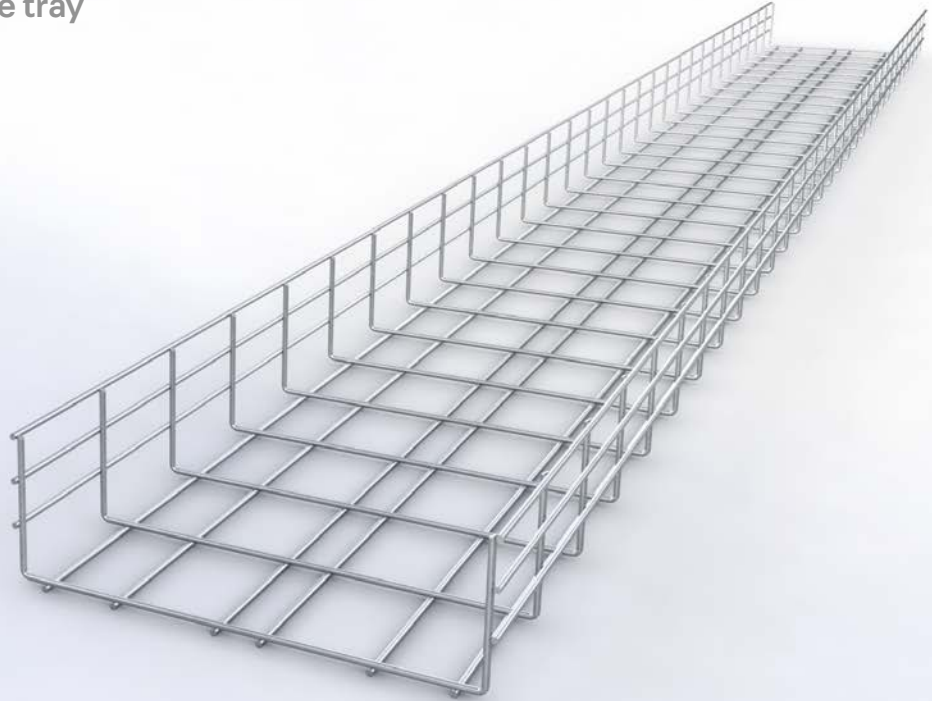

### Product features

- Height of sides: 103 mm
- Available tray widths: 116 to 618 mm
- Length: 3,000 mm
- Cross-sectional areas of 96 to 564 cm<sup>2</sup>
- Design: U-shaped



For information on how to assemble mesh cable trays with changes of direction, please see our associated assembly instructions, which are available at [www.pohlcon.com](http://www.pohlcon.com).

### Available surface coatings and materials

- GV** Zinc-plated in accordance with DIN EN ISO 2081
- S** Pre-galvanised wire in accordance with DIN EN 10244-2
- F** Hot-dip galvanised in accordance with DIN EN ISO 1461
- E** Stainless steel, material no. 1.4301 (V2A)
- E4** Stainless steel, material no. 1.4571/1.4404 (V4A)

## Technical data

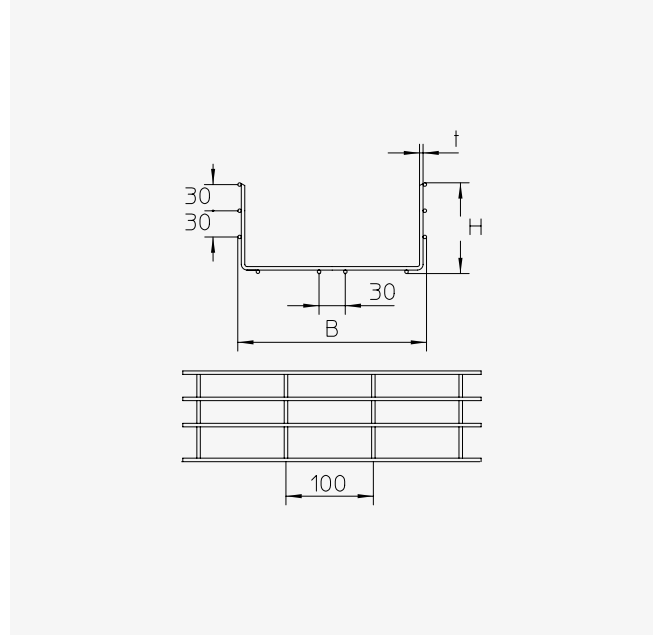
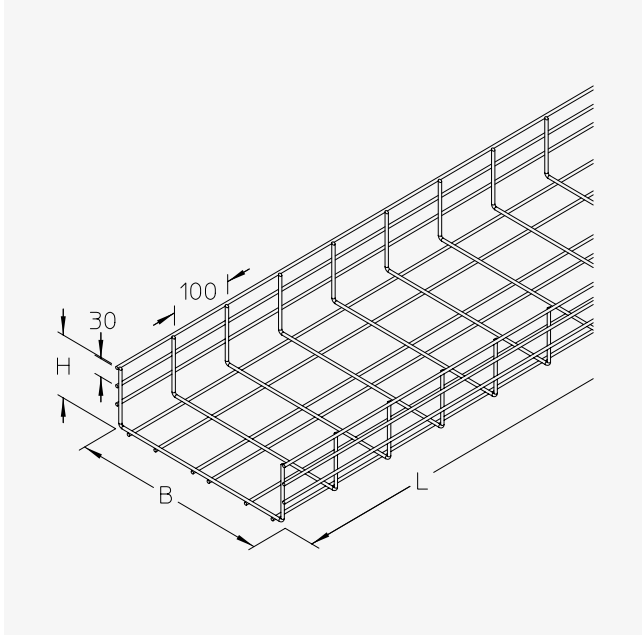

Model	H mm	B mm	L mm	t mm	A cm <sup>2</sup>	Q <sub>SK</sub> kN/m	G <sub>GV</sub> kg	G <sub>S</sub> kg	G <sub>F</sub> kg	G <sub>E</sub> kg	G <sub>E4</sub> kg
<b>G 100-10</b>	103	116	3,000	4.0	96	0.14	3.28	3.28	3.51	3.28	3.35
<b>G 100-20</b>	103	216	3,000	4.0	190	0.29	4.18	4.18	4.48	4.18	4.27
<b>G 100-30</b>	103	318	3,000	4.5	282	0.42	6.42	6.42	6.87	6.47	6.53
<b>G 100-40</b>	103	418	3,000	4.5	376	0.56	7.56	7.56	8.09	7.62	7.68
<b>G 100-50</b>	103	518	3,000	4.5	470	0.71	8.70	8.70	9.31	8.77	8.84
<b>G 100-60</b>	103	618	3,000	4.5	564	0.85	9.84	9.84	10.53	9.92	10.00

H: Height | B: Width | L: Length | t: Material thickness | A: Cross-sectional area | Q<sub>SK</sub>: Control cable distributed load | G: Weight (per surface)



Example order  
Model/version: G100-10S

# Load diagram

## G 100 S F E

$Q_{max}$  [kN/m]

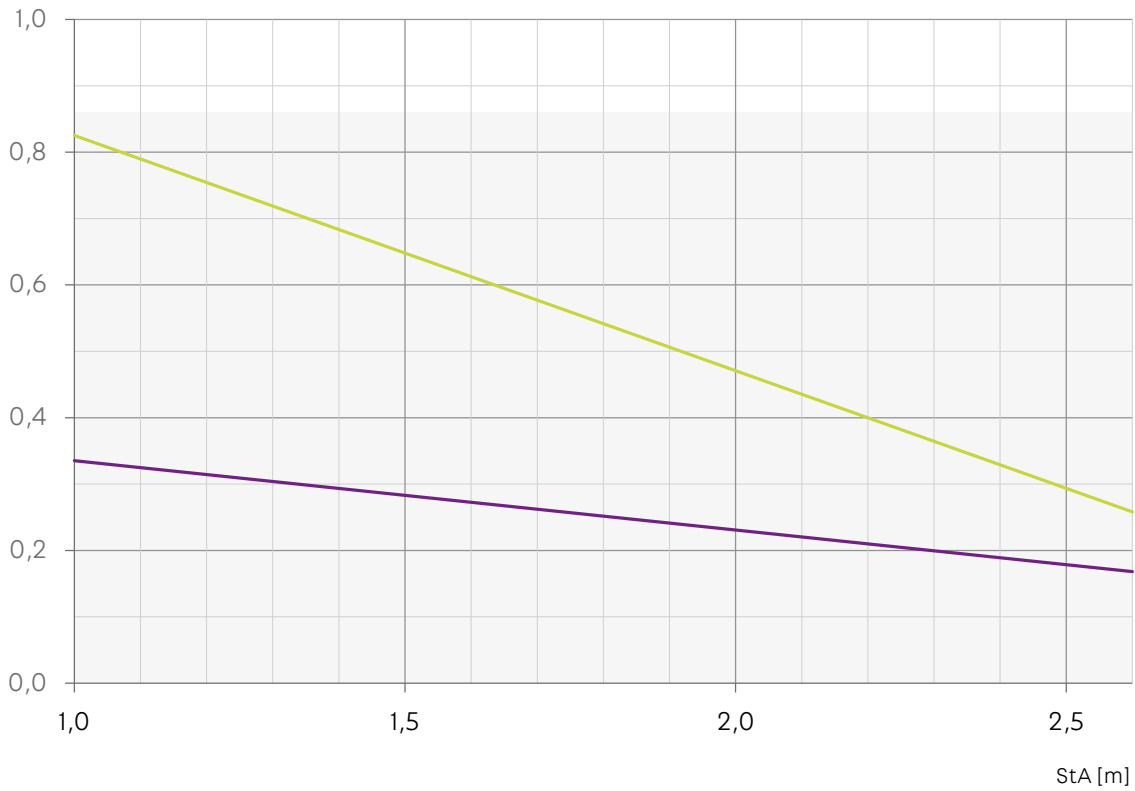

- Tray width: 100 to 300 mm
- Tray width: 400 to 600 mm

Filled to capacity with maximum tray width

$Q_{max}$ : Max. distributed load

StA: Support distance



UL classified

# GI

## C-shaped mesh cable tray



### Product features

- Height of sides: 75 mm
- Available tray widths: 76 to 316 mm
- Length: 3,000 mm
- Cross-sectional areas of 33 to 165 cm<sup>2</sup>
- Design: C-shaped



For information on how to assemble mesh cable trays with changes of direction, please see our associated assembly instructions, which are available at [www.pohlcon.com](http://www.pohlcon.com).

### Available surface coatings and materials

- GV** Zinc-plated in accordance with DIN EN ISO 2081
- S** Pre-galvanised wire in accordance with DIN EN 10244-2
- F** Hot-dip galvanised in accordance with DIN EN ISO 1461
- E** Stainless steel, material no. 1.4301 (V2A)
- E4** Stainless steel, material no. 1.4571/1.4404 (V4A)

## Technical data

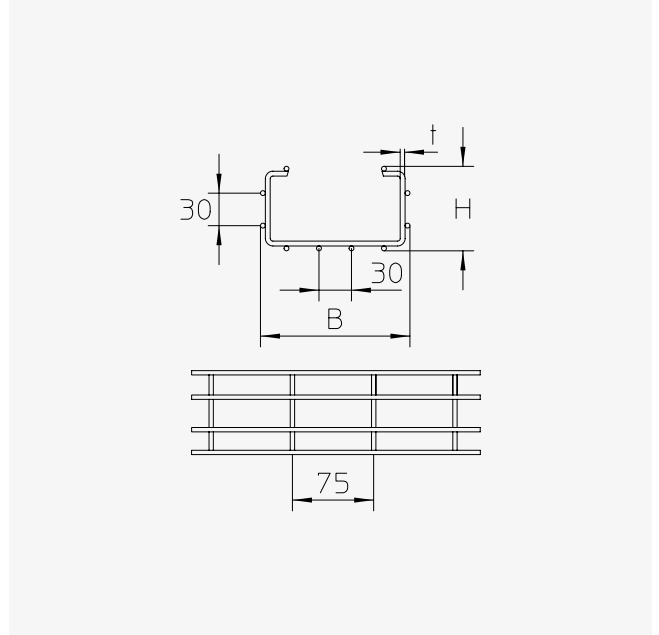
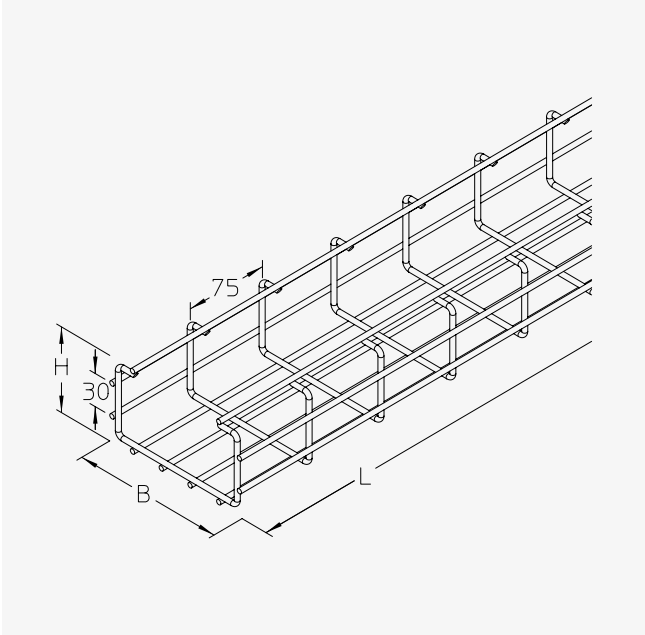

Model	H mm	B mm	L mm	t mm	A cm <sup>2</sup>	Q <sub>SK</sub> kN/m	G <sub>GV</sub> kg	G <sub>S</sub> kg	G <sub>F</sub> kg	G <sub>E</sub> kg	G <sub>E4</sub> kg
GI 06	75	76	3,000	4.5	33	0.05	4.10	4.10	4.39	4.12	4.18
GI 12	75	136	3,000	4.5	67	0.10	5.16	5.16	5.52	5.19	5.25
GI 20	75	216	3,000	4.5	113	0.17	5.57	5.57	5.96	5.60	5.67
GI 30	75	316	3,000	4.5	165	0.25	6.83	6.83	7.31	6.87	7.01

H: Height | B: Width | L: Length | t: Material thickness | A: Cross-sectional area | Q<sub>SK</sub>: Control cable distributed load | G: Weight (per surface)



Example order  
Model/version: GI 06S

# Load diagram

## GI S F E

$Q_{max}$  [kN/m]

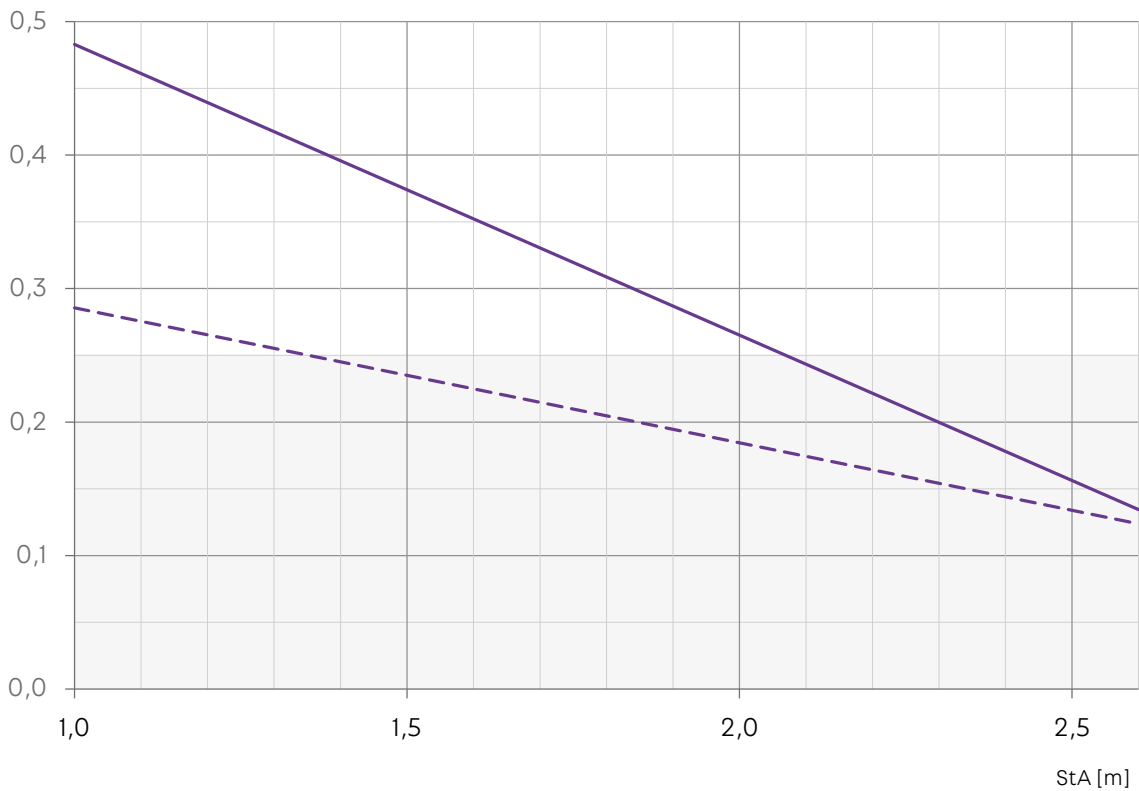

— Tray width: 76 to 316 mm in **S** **F**

- - - Tray width: 76 to 316 mm in **E**

▭ Filled to capacity with maximum tray width

$Q_{max}$ : Max. distributed load

StA: Support distance



UL classified

# GTDW

## G-shaped mesh cable tray

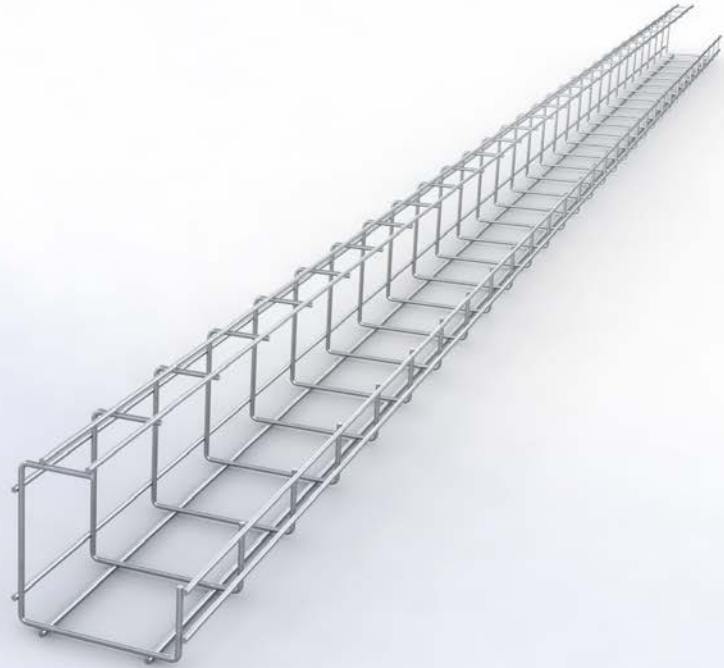

### Product features

- Height of sides: 44 to 115 mm
- Available tray widths: 75 to 149 mm
- Length: 3,000 mm
- Design: G-shaped
- For direct installation on ceilings or walls



For information on how to assemble mesh cable trays with changes of direction, please see our associated assembly instructions, which are available at [www.pohlcon.com](http://www.pohlcon.com).

### Available surface coatings and materials

- GV** Zinc-plated in accordance with DIN EN ISO 2081
- S** Pre-galvanised wire in accordance with DIN EN 10244-2
- F** Hot-dip galvanised in accordance with DIN EN ISO 1461
- E** Stainless steel, material no. 1.4301 (V2A)
- E4** Stainless steel, material no. 1.4571/1.4404 (V4A) (on request)

## Technical data

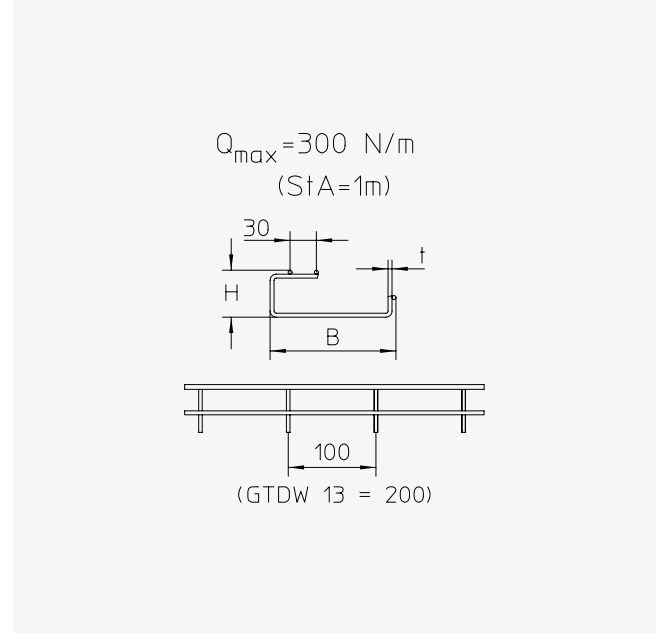
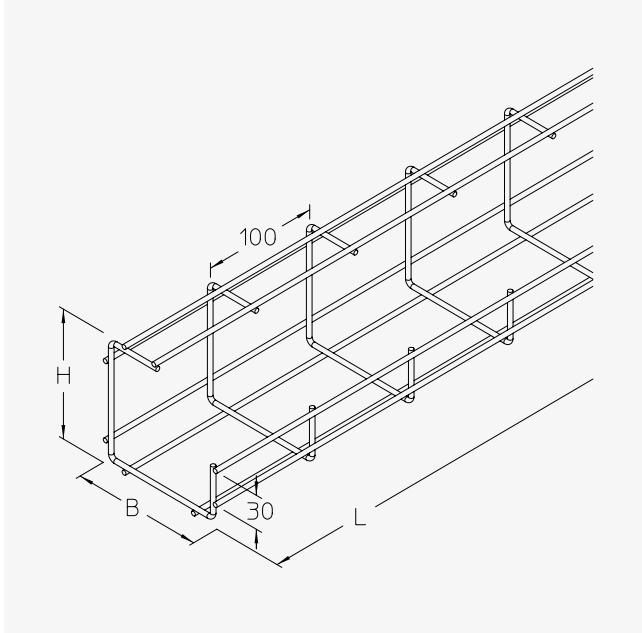

Model	H mm	B mm	L mm	t mm	A cm <sup>2</sup>	Q <sub>SK</sub> kN/m	G <sub>GV</sub> kg	G <sub>S</sub> kg	G <sub>F</sub> kg	G <sub>E</sub> kg
<b>GTDW 6</b>	44	75	3,000	4.0	17	0.02	-	2.26	2.41	2.26
<b>GTDW 8</b>	64	95	3,000	4.0	38	0.06	2.38	2.38	2.55	2.38
<b>GTDW 10</b>	115	115	3,000	4.0	98	0.15	3.28	3.28	3.51	3.28
<b>GTDW 13</b>	54	149	3,000	4.5	54	0.08	1.28	1.28	1.37	1.28

H: Height | B: Width | L: Length | t: Material thickness | A: Cross-sectional area | Q<sub>SK</sub>: Control cable distributed load | G: Weight (per surface)



Example order  
Model/version: GTDW 6S

# GTD 30

## W-shaped mesh cable tray

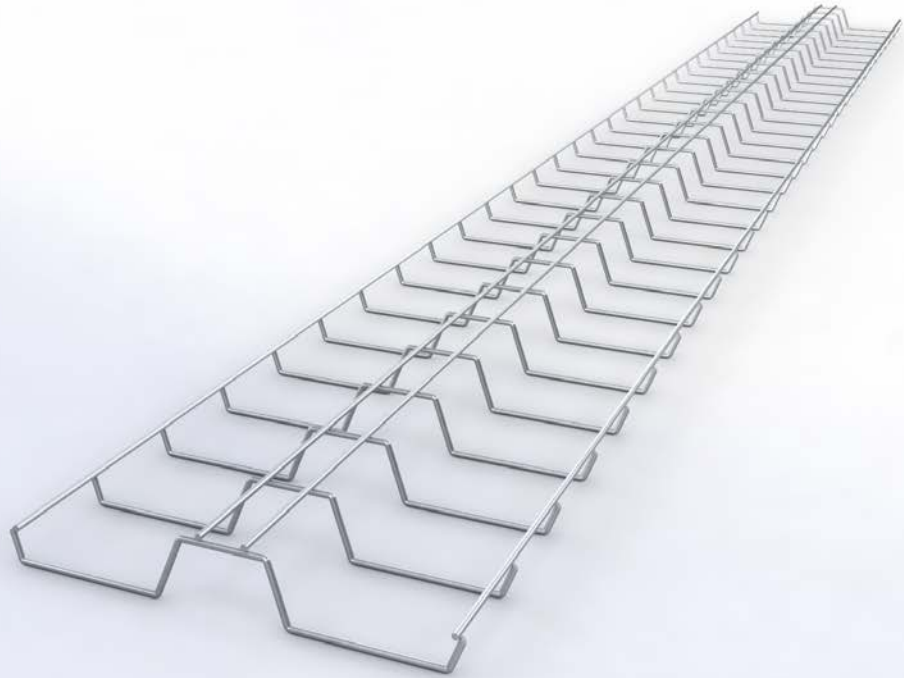

### Product features

- Height of sides: 50 mm
- Available tray width: 300 mm
- Length: 3,000 mm
- Design: W-shaped
- For direct installation on ceilings



For information on how to assemble mesh cable trays with changes of direction, please see our associated assembly instructions, which are available at [www.pohlcon.com](http://www.pohlcon.com).

### Available surface coatings and materials

- GV** Zinc-plated in accordance with DIN EN ISO 2081
- S** Pre-galvanised wire in accordance with DIN EN 10244-2
- F** Hot-dip galvanised in accordance with DIN EN ISO 1461
- E** Stainless steel, material no. 1.4301 (V2A)
- E4** Stainless steel, material no. 1.4571/1.4404 (V4A) (on request)

## Technical data

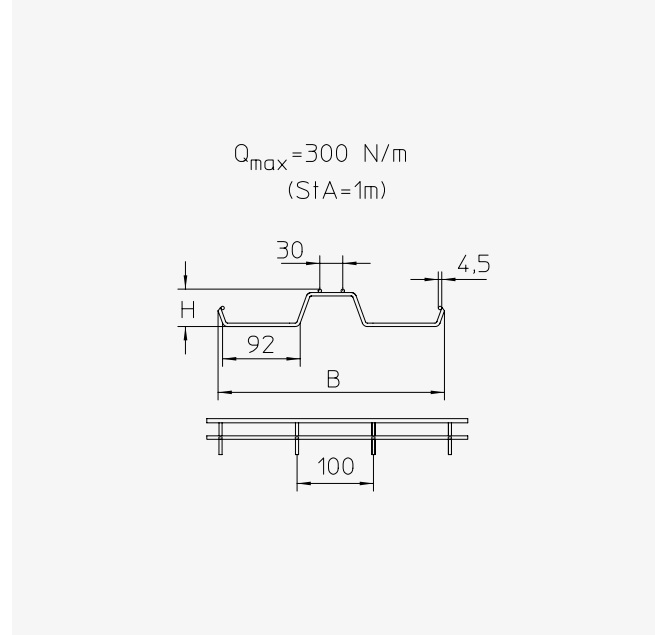
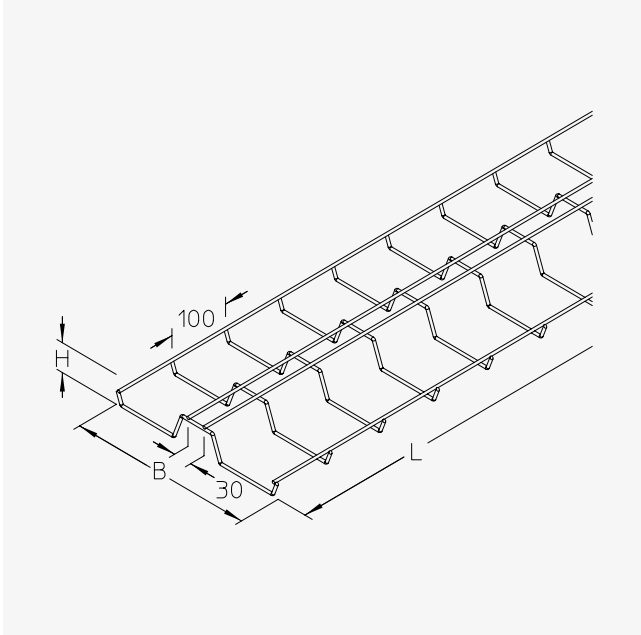

Model	H mm	B mm	L mm	t mm	A cm <sup>2</sup>	Q <sub>SK</sub> kN/m	G <sub>GV</sub> kg	G <sub>S</sub> kg	G <sub>F</sub> kg	G <sub>E</sub> kg
<b>GTD 30</b>	50	300	3,000	4.5	85	0.13	3.01	3.01	3.22	3.03

H: Height | B: Width | L: Length | t: Material thickness | A: Cross-sectional area | Q<sub>SK</sub>: Control cable distributed load | G: Weight (per surface)



Example order  
Model/version: GTD 30S

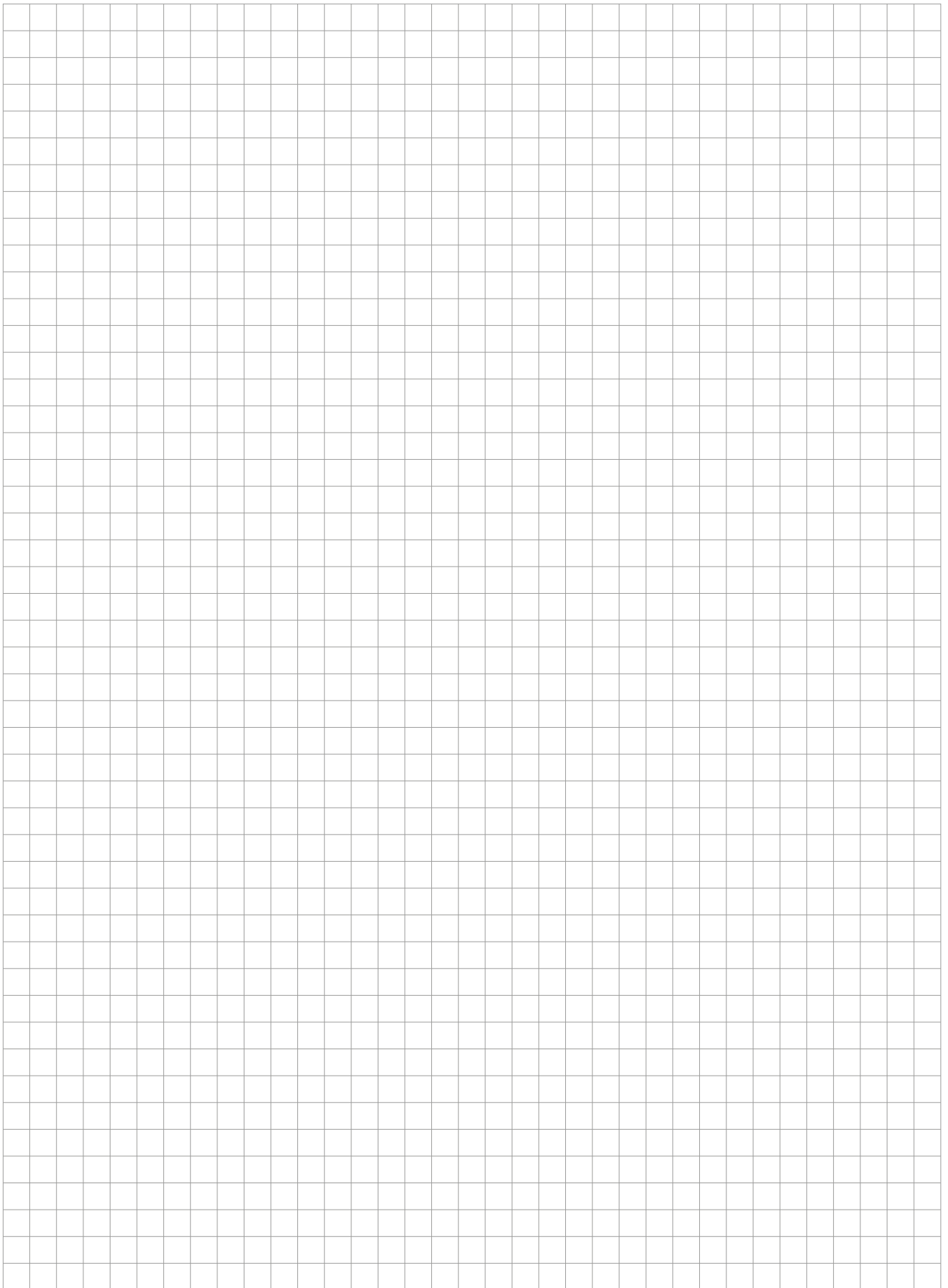

# Covers and installation components



**GD**  
(Locking) mesh cable tray cover



**GDR**  
(Locking) mesh cable tray cover with turning bolts



**GID**  
Mesh cable tray cover



**GIDR**  
Mesh cable tray cover with turning bolts



**GD-SW**  
Storm protection angle



**GID-SW**  
Storm protection angle



**MP-G**  
Assembly plate



**MP-G90**  
Assembly plate 90°



**GVR**  
Mesh cable tray snap-in connector



**GV 30**  
Mesh cable tray connector



**GVD 30**  
Mesh cable tray connector



**GV-L 30**  
Mesh cable tray connector



**GVK**  
Mesh cable tray connector clamp



**GVU**  
Mesh cable tray connector



**GTR 50**  
Mesh cable tray separating strip, height = 33 mm



**GTR 60**  
Mesh cable tray separating strip, height = 50 mm



**GTR 100**  
Mesh cable tray separating strip, height = 80 mm



**GKAB**  
Drop-out plate



**KLUGS**  
Clamping fasteners, universal, welded, vertical

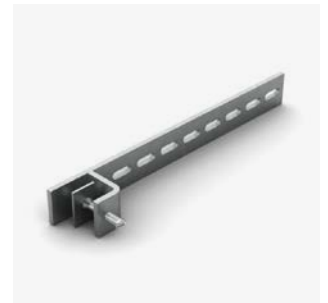

**KLUGW**  
Clamping fasteners, universal, welded, horizontal



**MKD**  
Mounting clamp



**MKD L**  
Connecting link

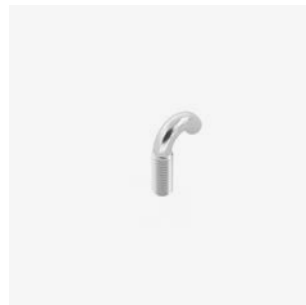

**GH**  
Fastening hooks



**GBH 30**  
Spacer bar for mesh cable tray grid size 30



**GBH 50**  
Spacer bar for mesh cable tray grid size 50



#### Support systems

In addition to the optional accessories, support structures are also required for fastening the mesh cable trays. We can offer you appropriate support elements for any cable management system to enable fastening to a wall or ceiling. These elements are available with various load-bearing characteristics.

Further information on our support structures can be found on our website at [www.pohlcon.com](http://www.pohlcon.com).

# Planning advices

## Standards and certificates

### Standards

Test standard DIN EN 61537 provides the technical basis for cable management systems.

This standard determines which test procedure is to be followed when testing the mechanical properties of the cable management elements. PohlCon constantly carries out extensive tests to ensure that the cable management systems it produces remain functional and fit for use at all times.

### Retention of function in the event of a fire

Our assembly instructions and technical information contain important safety details that must be heeded during assembly and use. Adhering to these ensures optimum safety of the cable management system used.

The maintenance of function of the normed supporting constructions and the system-specific-specified support systems in the event of fire are designed in accordance with DIN 4102-12. DIN 4102-12 specifies the requirements and testing for the maintenance of function of electrical cable systems in the event of fire.

### Certificates

As a manufacturer of cable management systems and associated components, PohlCon attaches great importance to product quality. Throughout the entire value chain, high standards of quality apply across all departments with a view to developing the best possible system for a range of complex application areas. In order for this quality standard to be achieved and monitored long term, PUK cable management systems are externally monitored and subject to in-house inspections.

On our own test benches, we test our cable management systems according to the strict specifications of DIN EN 61537, especially with regard to load-bearing capacity and functionality. This is supplemented by our quality management system, which has been established in the company since 1995.

Our quality management system is also capable of accommodating higher requirements, such as those in the petrochemical industry, and it is backed up by the SCCP certificate.

## Corrosion protection

### Basic information

Corrosion is the reaction of a metallic material with its environment. This leads to a change in the material and impairs the ability of a metallic component – or an entire system – to function. Corrosive media can take the form of room air, contamination in the air, water, a marine atmosphere or other chemicals. Interactions between these corrosive media cause a corrosive layer to form, leading to metal attack.

If corrosion damage does occur, very high costs can sometimes be incurred. To avoid corrosion damage, we recommend selecting a suitable material and an appropriate surface coating. The environmental conditions of the products should therefore always be taken into account during planning in addition to their intended use to ensure that the relevant corrosion protection classes are adhered to.

**Table 1: Atmospheric corrosivity categories and examples of typical environments**

Corrosivity category	Mass loss/thickness loss per unit surface area (after first year of exposure)				Examples of typical environments (for information purposes only)	
	Unalloyed steel		Zinc		Exterior	Interior
	Mass loss g/m <sup>2</sup>	Thickn. loss µm	Mass loss g/m <sup>2</sup>	Thickn. loss µm		
<b>C1</b> Negligible	≤ 10	≤ 1.3	≤ 0.7	≤ 0.1	-	Heated buildings with neutral atmospheres, e.g. offices, shops, schools, hotels
<b>C2</b> Low	> 10 to 200	> 1.3 to 25	> 0.7 to 5	> 0.1 to 0.7	Atmospheres with low level of pollution. Mostly rural areas	Unheated buildings where condensation may occur, e.g. warehouses, sports halls
<b>C3</b> Medium	> 200 to 400	> 25 to 50	> 5 to 15	> 0.7 to 2.1	Urban and industrial atmospheres with moderate sulphur dioxide pollution; coastal atmospheres with low salinity	Production areas with high humidity and some air pollution, e.g. food processing plants, laundries, breweries, dairies
<b>C4</b> High	> 400 to 650	> 50 to 80	> 15 to 30	> 2.1 to 4.2	Industrial atmospheres and coastal atmospheres with moderate salinity	Chemical plants, swimming pools, coastal shipyards and boat harbours
<b>C5</b> Very high	> 650 to 1,500	> 80 to 200	> 30 to 60	> 4.2 to 8.4	Industrial areas with high humidity and aggressive atmospheres, and coastal atmospheres with high salinity	Buildings or areas with almost permanent condensation and with high pollution
<b>CX</b> Extreme	> 1,500 to 5,500	> 200 to 700	> 60 to 180	> 8.4 to 25	Offshore areas with high salinity and industrial areas with extreme humidity and aggressive atmosphere, and subtropical and tropical atmospheres	Industrial areas with extreme humidity and aggressive atmosphere

Source: DIN EN ISO 12944-2:2018-04

Note: The loss values for the corrosivity categories are identical to the values in ISO 9223.

Conversion: 10 N corresponds to approx. 1 kg.

## Surface coatings and materials

Several measures can be taken to protect components against the corrosive conditions prevailing at the place of use. When deciding on a particular cable management system, care must therefore be taken to select suitable materials and a design that ensures proper corrosion protection while also paying careful attention to the protective layers and metallic coatings.

For installations in normal environments, zinc coatings have proven themselves to be an effective corrosion inhibitor for steel. However, the protective zinc layer gets worn away by various climatic influences over time. Calculating the thickness of the zinc layer required for different environmental conditions is a question of multiplying the erosion rate by the planned service life of the system.

DIN EN ISO 12944-2:2018-04 (Table 1) provides an overview of how the corrosion categories are assigned while taking account of the environment and the associated annual thickness loss of the zinc layer.

PohlCon offers several coating systems that differ from one another in terms of layer thickness, adhesion and appearance. In addition, most of our cable management systems can be supplied as stainless steel versions.

Alternatively, the PUK brand XC Duplex Coating System can be used for highly corrosive environments (corrosion category C5). The XC coating has been successfully tested in accordance with the DIN EN ISO 12944-6 standard and offers great flexibility with regard to use. With its specially developed formula, it provides a smooth, bubble-free and even coating surface.

### Zinc electroplating (DIN EN ISO 4042)

The components to be coated are placed in an electrolytic bath, where zinc ions are deposited very evenly on the material being galvanised. This results in the formation of a bright and shiny zinc layer with a thickness of approximately 5 µm. To protect this layer against abrasion, it subsequently undergoes bichromate coating process. Within our product range, the relevant bolting fasteners/bolts and nuts are identified by the code **GV**. These are used to connect components galvanised using the sendzimir process.

### Hot galvanisation according to the Sendzimir process (DIN EN 10346, DIN EN 10244-2)

In the rolling mill itself, a wide strip (sheet thickness ≤ 2.0 mm) is coated with zinc continuously as it passes through. This results in an even and strongly adhering zinc layer with an average thickness of 19 µm. Damage to the zinc layer by cutting, piercing/perforation, drilling, etc. does not lead to any progression of the corrosion because the adjacent zinc forms into solution due to the effect of (air) humidity, causing a brownish layer of protective zinc hydroxide to form on the bare cut surfaces. The "migration" of zinc ions protects exposed surfaces up to a width of approximately 2.0 mm. Steel wire and wire products are galvanised in accordance with DIN EN 10244-2.

Products with this type of coating are identified by the code **S**.

### Batch galvanisation (DIN EN ISO 1461)

Hot-dip galvanisation (DIN EN ISO 1461)

Once they have been worked, the parts that are to be coated are immersed in molten zinc (approx. 450°C). Chemical reactions create various zinc-iron alloys that have a particularly strong bond with the steel core. These alloys are usually coated with a "pure zinc" layer. However, depending on the reaction rate, composition of the steel, immersion time, cooling process, etc., the zinc-iron alloys can run right through to the surface level due to a sort of "marbling" effect. For this reason, the surface appearance can vary from bright and shiny through to matt dark grey, although nothing can be inferred about the thickness of the zinc layer or the quality of corrosion protection from this. In addition, humid environments lead to the formation of zinc hydroxide carbonate (known as white rust), particularly on new zinc surfaces. This has absolutely no impact on the corrosion protection properties. Cut surfaces have to be protected with cold zinc paint.

According to DIN EN ISO 1461, the average layer thickness is

at least the following for steel and non-centrifuged parts:

- 45 µm for material thicknesses <1.5 mm
- 55 µm for material thicknesses ≥ 1.5 mm and ≤ 3 mm
- 70 µm for material thicknesses > 3 mm and ≤ 6 mm

at least the following for centrifuged parts (incl. castings):

- 45 µm for material thicknesses <3 mm
- 55 µm for material thicknesses ≥ 3 mm

DIN EN ISO 1461 essentially corresponds to BS EN ISO 1461 in the UK, to EN ISO 1461 in France and to NEN EN 1461 in the USA. All cable tray types and all medium to heavy-duty support systems are available in a hot-dip galvanised version.

Products with this type of coating are identified by the code

**F**.

### Stainless steel

In view of its high corrosion resistance, ease of surface cleaning, recyclability and reaction to fire, stainless steel is increasingly becoming the material of choice. Its use is predominantly on the rise in the chemicals, paper, textile and food industries, as well as in wastewater treatment plants, refineries, vehicle tunnels and offshore plants. Compared to various types of plastic, the advantages of stainless steel are its high strength, temperature and fire resistance, and the fact that it does not produce any emissions in the event of fire or during machining.

PohlCon offers two stainless steel versions of its cable management systems as standard.

The most commonly used type is material no. 1.4301 (V2A), which has the short designation X5CrNi 18-10 according to EN 10088-2. It is approved by the Deutsches Institut für Bautechnik (DIBt) in Berlin under general technical approval Z-30.3-6. The following standards are related:

- EN 10088-2 1.4301 X5CrNi 18-10
- AISI 304
- UNS S 30400
- BS 304 S31
- AFNOR Z7CN 18-09
- DIN 17441

PohlCon offers a complete range of stainless steel products: bracket supports, brackets, cable trays, cable ladders, vertical ladders, profile rails and cable clamps. The bolting fasteners/ bolts and nuts correspond to steel group A2 (according to DIN ISO 3506). The products made from this material are identified by the code **E**.

On request, products from the stainless steel range are also available in versions made from the material with no. 1.4571/1.4404 (V4A), which has the short designation X6CrNiMoTi17-12-2 according to EN 10088-2. This is likewise approved by the Deutsche Institut für Bautechnik (DIBt) in Berlin. The bolting fasteners/bolts and nuts meet the requirements of steel group A4 (according to DIN ISO 3506). This material is referred to in the following standards:

- EN 10088-3 1.4404 X2CrNiMo 17-12-2
- AISI 316 L
- UN S 31603
- BS 316 S 11
- AFNOR Z3CND17-11-02/ Z3CND 17-12-02
- DIN 17440 1.4404

1.4571 is available as an alternative to this material. This type of steel is identified by the code **E4**.

Other materials with the same corrosion class can be supplied on request. To cater for special applications (lighting and cable support systems in road tunnels according to ZTV-ING), the high-alloy stainless steel with material no. 1.4529 is available for the relevant product versions.

### XC coating for highly corrosive environments

The XC Duplex Coating System enables reliable protection in highly corrosive environments. With its XC system – which has been successfully tested for corrosion category C5-M – PohlCon offers the longest lasting corrosion protection (up to 25 years) for cable management systems available on the market.

XC consists of a zinc layer and a single-layer powder coating, which together adhere extremely well to the component. With powder coating thicknesses starting from 150 µm and zinc layer thicknesses from 55 µm, XC can be used to achieve an exceptionally smooth and even surface that is free of bubbles. In the event that it should become damaged, the XC coating can be touched up in the case of (more extensive) damage.

We recommend the use of XC coatings in offshore areas with high salinity, in industrial zones with extreme air humidity and in aggressive, subtropical and tropical atmospheres.

# Calculations for selecting the right system

## Cable selection

To be selected on the basis of:

1. The quantity or volume of cables that a cable tray is intended to hold (**capacity or size of cable tray**)
2. The weight of the cables that a cable tray is intended to hold (**type of cable tray**)
3. The distance between the cable tray support points (**load-bearing capacity of cable tray**)

## Capacity/useful cross section

If the cable volume (types, sizes and number of cables) is unknown, you can estimate it using Table 2 "Space requirements and weight of NYY-type cables".

For each size of cable, the amount of space required must be multiplied by the number of cables of that size. These values must then be added together to give the grand total. This results in the minimum cross-sectional area (A) of the cable tray you are looking for. Where necessary, we recommend working with a reserve factor. Regardless of this, the stipulations of VDE 0100 on the occupancy of cable trays must always be observed.

The usable cross-sectional area (A) of each cable tray is specified in the product tables. Depending on the application, several cable trays may be laid parallel to one another.

## Cable weight

The exact details provided by the cable manufacturer can usually be used for this purpose. Relevant lists or tables can generally be requested directly from the manufacturer so that the cable weights can be calculated as accurately as possible.

If the total weight of the cables is unknown, you can estimate it using Table 2 "Space requirements and weight of NYY-type cables".

For each cable size, the cable weight must be multiplied by the number of cables. These values must then be added together to give the grand total. This results in the estimated cable load (Q).

## Load-bearing capacity/support distance

All stated load-bearing capacities relate to the product concerned.

The load-bearing capacity of the installed system depends on how the system is filled/loaded and, in particular, how the load is applied to the supporting structure.

However, from a safety perspective, the maximum possible cable load is crucial. DIN VDE 0639-1 is a good source of reference if you require further design and calculation criteria. The result of the distributed load for the respective cable type (control cable  $Q_{SK}$  or power cable  $Q_{LK}$ ) is specified for each cable tray in the tables.

## Support distance

The recommended standard support spacing is 1.5 m. However, a greater spacing may actually be possible depending on the specified fastening options (pillars, purlins, etc.). The load diagrams must be used to determine the maximum load ( $Q_{max}$ ) that the cable tray can support with the given support spacing.

**Table 2: Space requirements and weight of NYY-type cables**

<b>NY Y cable</b>	<b>Diameter</b> mm	<b>Space required per cable</b> cm <sup>2</sup> (approx.)	<b>Cable weight</b> N/m (approx.)	<b>Number of cables</b>
<b>4 x 1.5</b>	12.5	1.5	2.3	n
<b>4 x 2.5</b>	14.0	1.8	3.0	n
<b>4 x 6</b>	16.5	3.0	5.2	n
<b>4 x 16</b>	22.0	5.0	11.0	n
<b>4 x 35</b>	31.0	12.0	22.0	n
<b>4 x 70</b>	41.0	16.0	41.0	n

Conversion: 10 N corresponds to approx. 1 kg.

### Example 1

Determining the maximum permissible additional load  $Q_{Zus}$  based on the example of the G 50-40S with support distance  $StA$  of 1.5 m

The load diagram data and Table 3 data are known from the product documentation:

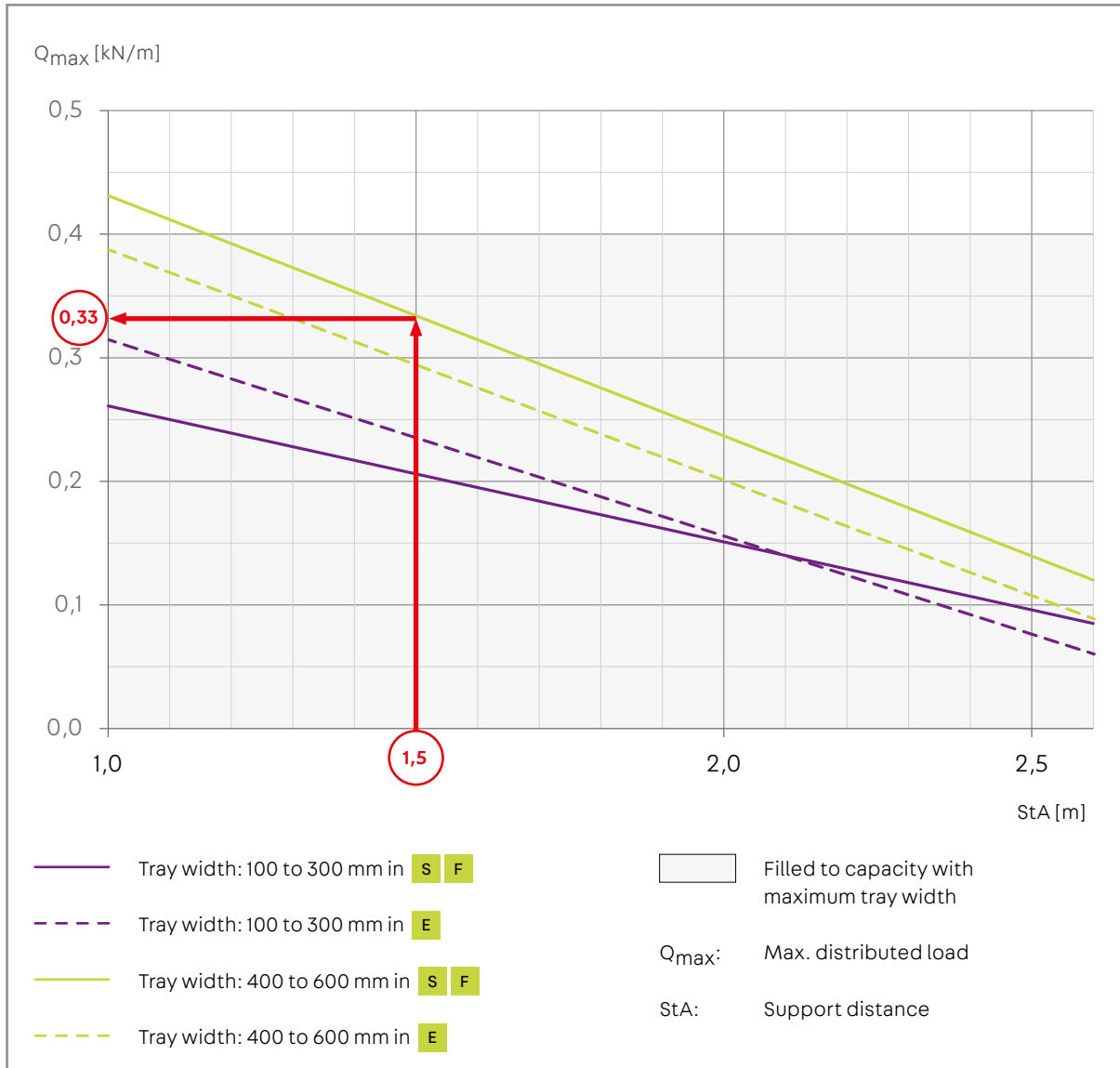

Figure 1: G 50 load diagram with support spacing of 1.5 m marked

### Table 3: Data for the G50-40S from the product table (p.13)

Model	B mm	A cm <sup>2</sup>	Q <sub>SK</sub> kN/m
G 50-40S	418	176	0.26

For support distance  $StA = 1.5$  m, the load diagram reveals that:

$Q_{max} = 0.334$  kN/m

The maximum permissible additional load being sought is the difference between the maximum load and the potential cable load:

$SQ_{max} - Q_{SK} = Q_{Zus}$

$0.334$  kN/m -  $0.25$  kN/m =  $0.084$  kN/m



Thus, with  $StA = 1.5$  m, the maximum permissible additional load is 0.08 kN/m.

## Example 2

Determining the maximum support distance  $StA$  based on the example of the G 50-10F with an additional load of 0.1 kN/m.

The load diagram values and Table 4 values are known from the relevant product-specific data:

**Table 4: Data for the G 50-10F from the G 50 product table**

Model	B mm	A cm <sup>2</sup>	Q <sub>SK</sub> kN/m
G 50-10F	116	45	0.07

According to Table 4, the distributed load of the control cable is:  $Q_{SK} = 0.07 \text{ kN/m}$

The maximum load is calculated by rearranging the equation from example 1:  $Q_{max} = Q_{Zus} + Q_{SK}$

$$0.17 \text{ kN/m} = 0.1 \text{ kN/m} + 0.07 \text{ kN/m}$$

 With a maximum load  $Q_{max}$  of 0.17 kN/m, the resulting maximum support spacing for the G50-10F is 1.7 m (according to the load diagram).

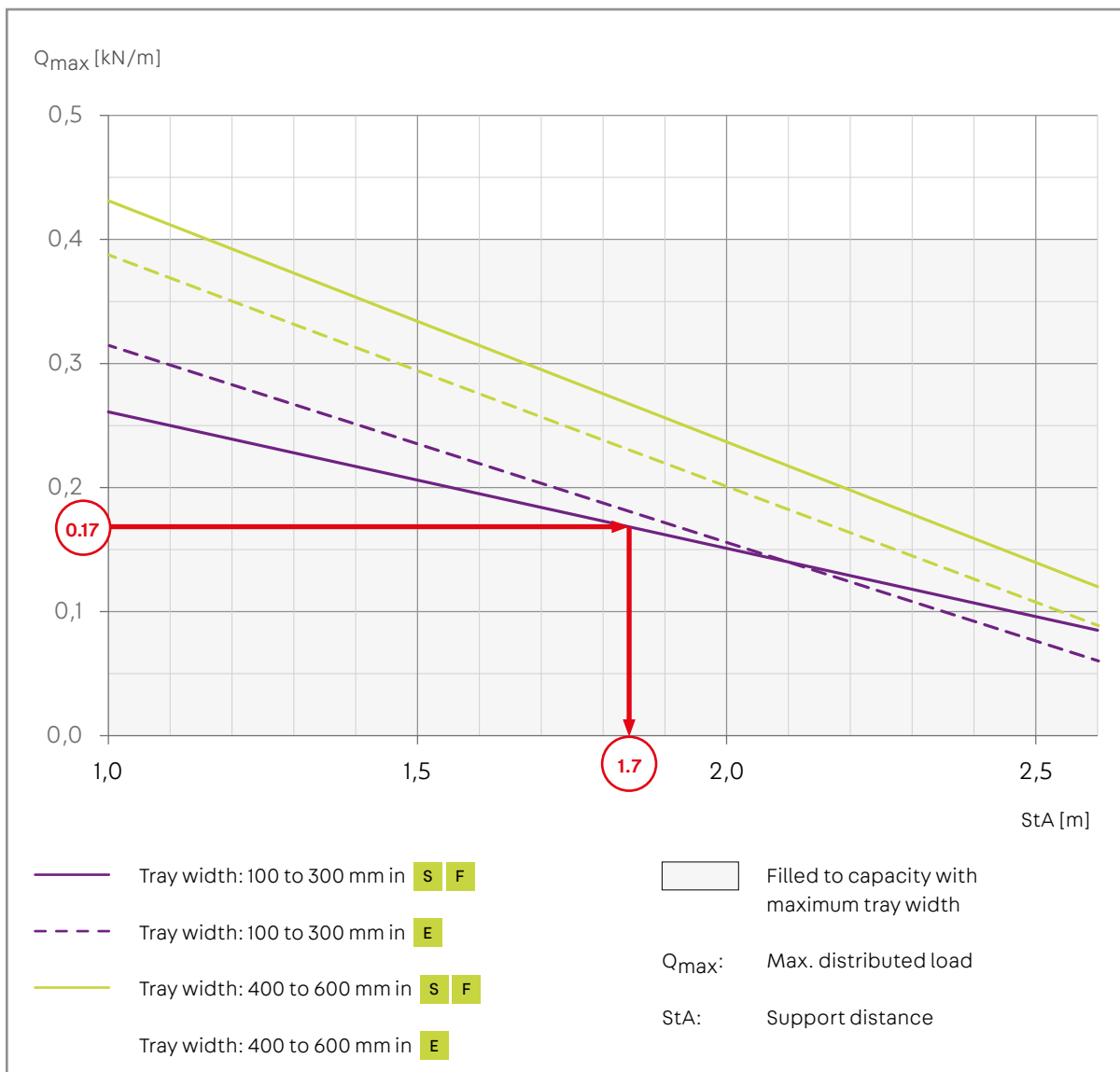

Figure 2: G 50 load diagram with the maximum load  $Q_{max}$  marked for the purpose of determining the maximum support distance  $StA$

# Alternative cable tray types

## A higher load with the same support distance

As an alternative, other cable management systems can be used for a defined support spacing. This technique enables the use of alternative systems that are capable of transmitting higher loads because of their rigidity.

**The load-bearing capacities must be observed for the cable management systems selected, along with the permissible support spacings!**

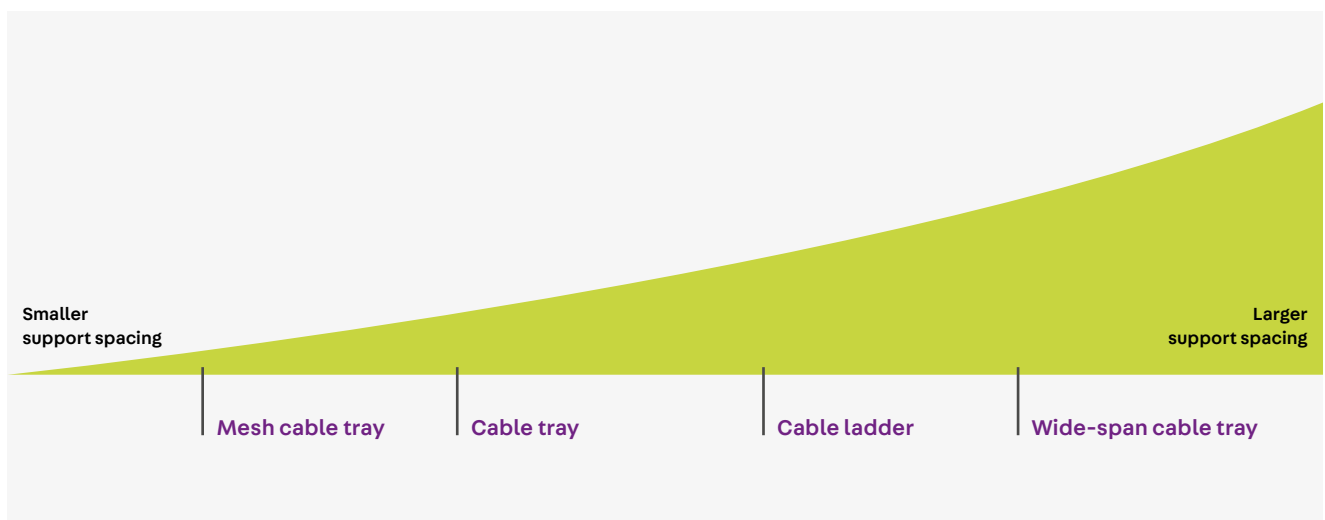

Figure 3: Alternative cable management systems according to permissible support spacings

### Selecting the right support system

When routing cable trays on ceilings, the support systems usually consist of a stem supports and ceiling supports. When attaching cable trays to walls, wall brackets, profile rails and stem supports are used. To enable the selection of systems with sufficient load-bearing capacity, the first step is to calculate the load of each cable tray at the support point.



The load diagrams already have a safety concept built in. This is because the load-bearing capacities – which have been determined in accordance with test standard DIN 61537 – have appropriate safety factors applied to them. If the load levels or support distances are not sufficient for proper dimensioning of the cable management systems, the next version up (i.e. one with higher load levels) must be selected or the support distances must be reduced.

## Useful information

### Application of loads to the building structure

All stated load-bearing capacities relate to the product concerned. The load-bearing capacity of the installed system depends on the dimensions and materials used in each case and, in particular, on how the load is applied to the building structure. Substantial additional loads can occur when installing cables. Care must be taken to prevent these additional loads from being permanently applied to the cable management system.

### Substrate

The condition and properties of the substrate and the type of wall or ceiling have a major impact on the fastening of support systems. To enable a better assessment of concealed, plastered or painted substrates, it is helpful to carry out sample drilling.

This will enable you to attach the cable trays to any of the following using the appropriate support systems: timber, mortar, sandstone, limestone, concrete, solid brick, perforated brick, aerated concrete, wallboard, gypsum board, gypsum fibreboard and insulating board. Within this context, special attention must be paid to the dowels because they transmit the loads further into the substrate.

### Permissible dowel load $F_{Zul}$

The dowel load is a superposition of vectors that represent various force components acting on the fastening point (e.g. shear force and vertical pull-out force). This must be less than or equal to the permissible dowel load specified in the approval. This generally applies to all diagonal pull directions. The permissible dowel load depends on the anchorage (concrete grade, type of masonry brick, etc.) and stress exerted on it:

- Cracked concrete tensile zone
- Verified concrete compression zone (e.g. concrete wall, concrete supports, upper half of concrete girder).

In cases of doubt, advice must be sought from the responsible structural engineer.

### Reduction

The permissible dowel load  $F_{Zul}$  must be reduced if:

- Several dowels are closer to each other than dimension  $a$  of the centre-to-centre distance.
- The distance between the dowel and an edge/corner of the building structure is less than edge distance dimension  $a_r$ .

Whenever you are planning cable management systems, it is important to remember that the filling capacity of cable trays may exceed their load-bearing capacity. You must allow sufficient reserves and, where applicable, plan using a multi-layered approach.



For detailed information, use the online expert chat service at [www.pohlcon.com](http://www.pohlcon.com) (only available in German) or speak to a PohlCon consulting engineer.

# Testing according to DIN EN 61537

## Cable management systems

Among other things, DIN EN 61537 determines which test procedure is to be followed when testing the mechanical properties of the cable support elements.

The following undergo testing:

1. Cable trays including connectors with an appropriate design

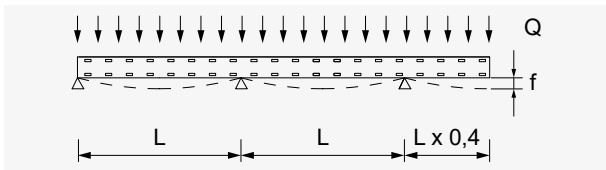

Figure 4: Load diagram for the testing of a cable tray

Q: Distributed load | L: Support distance

2. Brackets as an individual component, i.e. without the reinforcing effect provided by assembled cable trays. The stated load-bearing capacities are based on the loads measured with a level of deformation that is still permissible ( $f_{ZUL}$ ) for the cable support elements in the respective standard version (e.g. Sendzimir/hot-dip galvanised).

## Safety

A safety factor of 1.7 must be incorporated into the tested structures, as per the safety concept required under the test standard. The failure scenario possible as a result is not tantamount to the respective structure breaking. Rather, it involves the structure becoming so heavily deformed that no further increase in load can be registered. For this reason, the elastic-plastic deformability of metal cable support systems makes them preferable to brittle plastic systems that break easily.

Whenever you are planning cable management systems, it is important to consider that the filling capacity of cable trays may exceed their load-bearing capacity. Therefore, you must factor in sufficient reserves and, where applicable, plan using a multi-layered approach.

## Cable trays

The cable trays undergo testing on a specially developed test stand. This ensures even surface loading of the components that bend elastically under load.

$$f_{ZUL} \text{ (in longitudinal direction)} = 0.01 \times \text{support distance StA}$$

$$f_{ZUL} \text{ (in transverse direction)} = 0.05 \times \text{cable tray width B}$$

## Arms/brackets

Under a vertical load, the tips of the arms are allowed to drop by:

$$f_{ZUL} = 0.05 \times \text{arm length (but } \leq 30 \text{ mm)}$$

## Stems (bracket supports)

The stems undergo various tests. Careful attention is paid to the following points when testing the stems:

- Bending from to lateral application of force; the permissible deflection within this context is  $f_{ZUL} = 0.05 \times \text{stem length}$
- Application of force in connection with arms
- Pull under centric load

## Equipotential bonding

Equipotential bonding is implemented between electrically conductive components with different levels of electrical potential. The primary purpose of this is to provide protection against electric shock but, at the same time, it protects the electrical equipment in the event of excess voltage. Over time, the effect of equipotential bonding has become ever more important in relation to electromagnetic compatibility (EMC). When electricity flows through conductors, it generates magnetic fields. Due to the large number of wiring systems installed in buildings, these can then have a negative effect on electromagnetic compatibility. Low potential differences are extremely important for ensuring that an electrical installation is electromagnetically compatible.

In the case of PUK cable management systems that are assembled using bolted connections, the equipotential bonding has been verified in accordance with DIN EN 61537. In all other cases, the equipotential bonding must be ensured by further mechanical means.

# Application examples

## Connector assembly

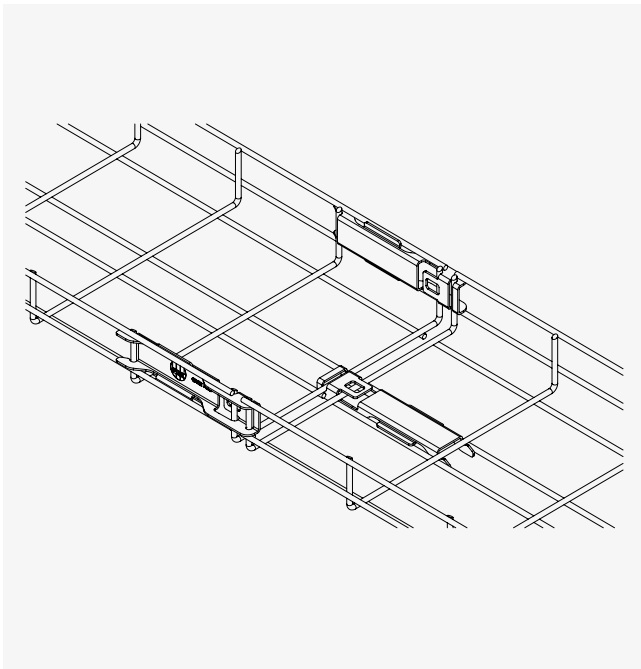

A U-shaped mesh cable tray connected using the GVR mesh cable tray snap-in connector.

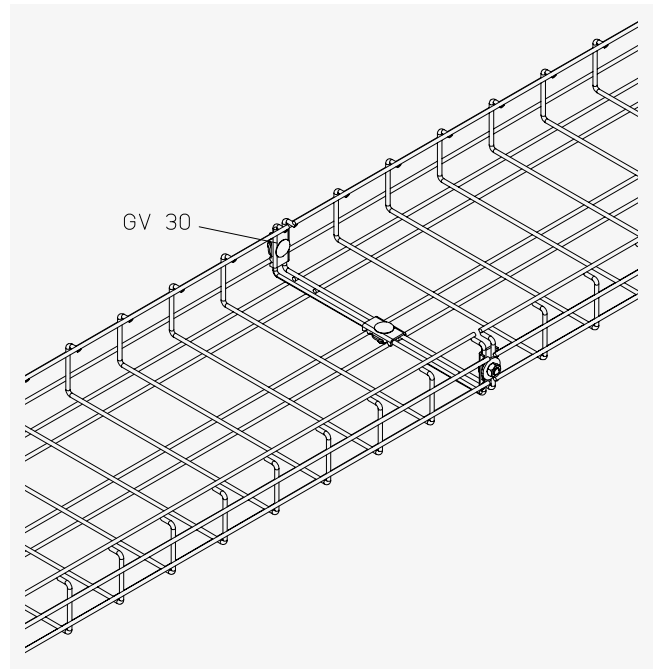

A C-shaped mesh cable tray connected using the GV 30 mesh cable tray connector set.

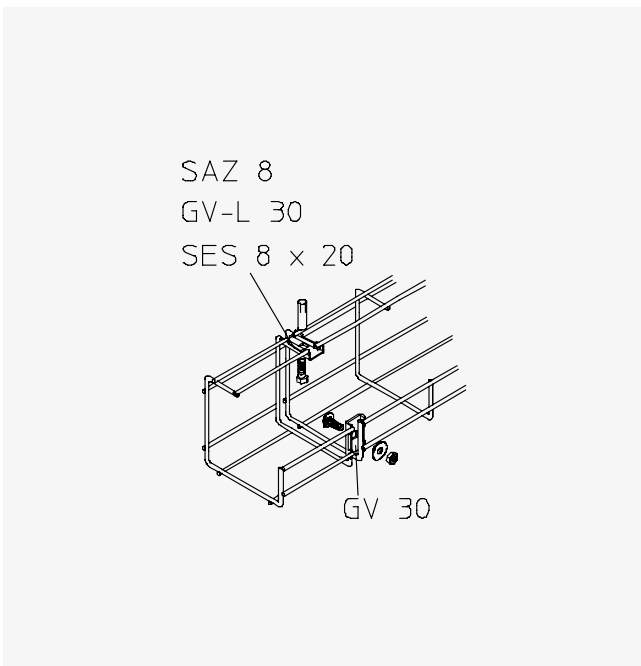

A G-shaped mesh cable tray connected using the GV 30 mesh cable tray connector set.

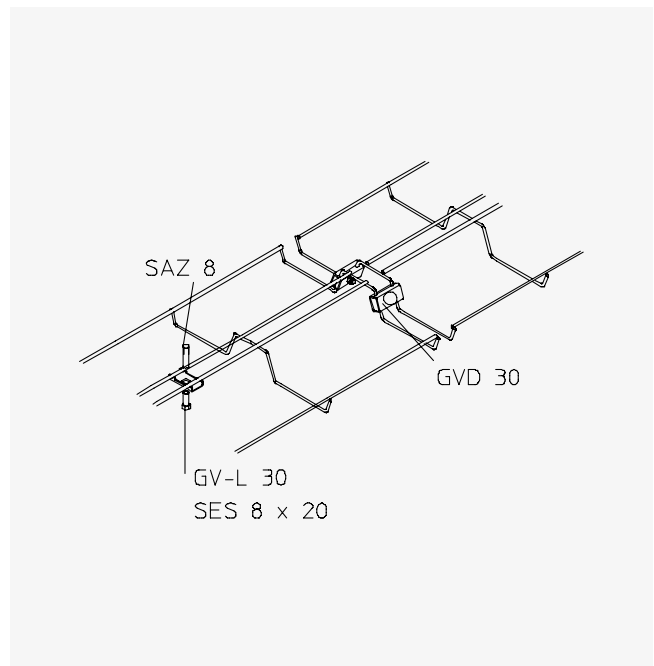

A W-shaped mesh cable tray connected using the GVD 30 mesh cable tray connector set.

## Separating strip mounting   Drop-out plate mounting

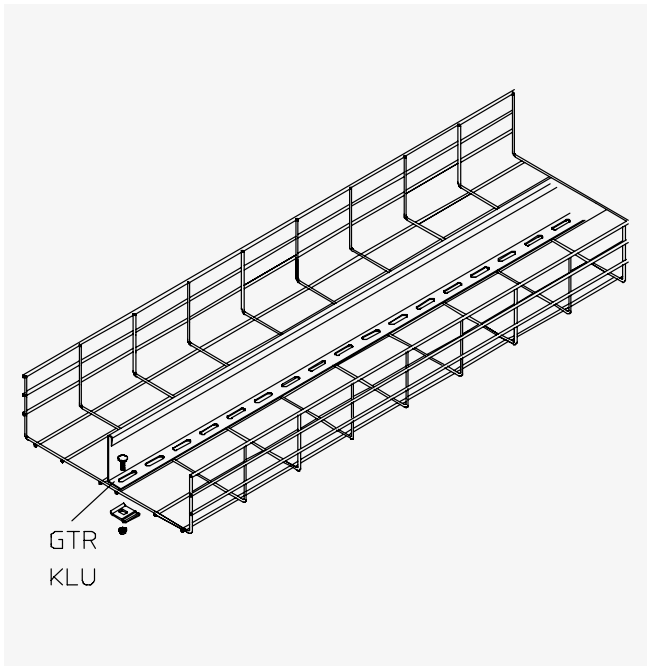

A GTR separating strip mounted on a U-shaped mesh cable tray using the KLU clamp fastening set.

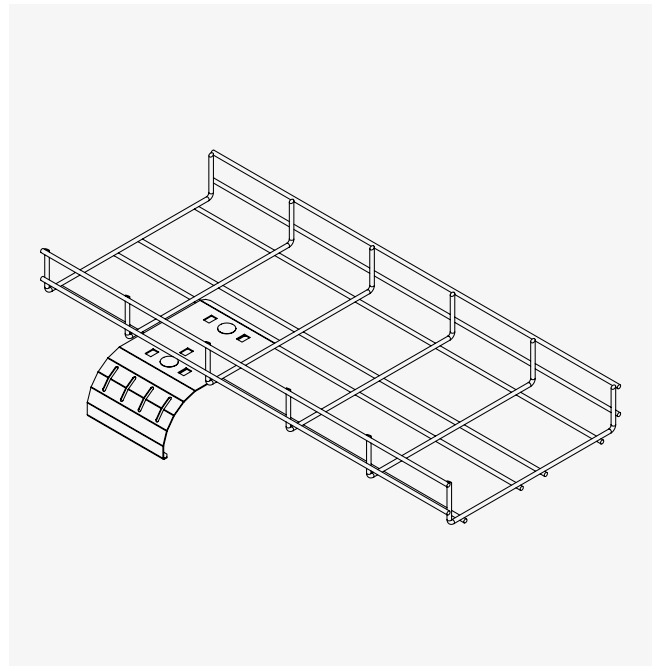

The GKAB drop-out plate mounted on a U-shaped mesh cable tray.

## Assembly plate mounting

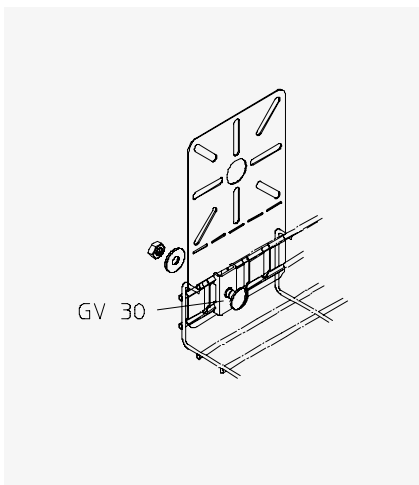

An MP-G assembly plate (for attaching junction boxes to a U-shaped mesh cable tray) mounted using the GV 30 mesh cable tray connector set

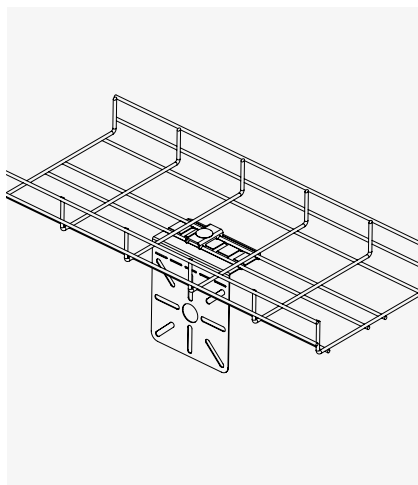

An MP-G 90° assembly plate (for attaching junction boxes to a U-shaped mesh cable tray) mounted using the GV 30 mesh cable tray connector set

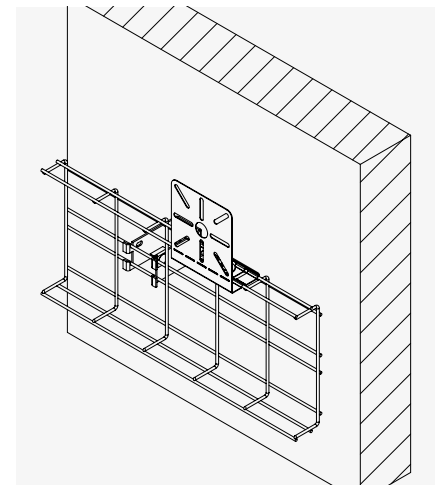

An MP-G 90° assembly plate (for attaching junction boxes to a vertically aligned U-shaped mesh cable tray) mounted using the GV 30 mesh cable tray connector set

## Wall mounting

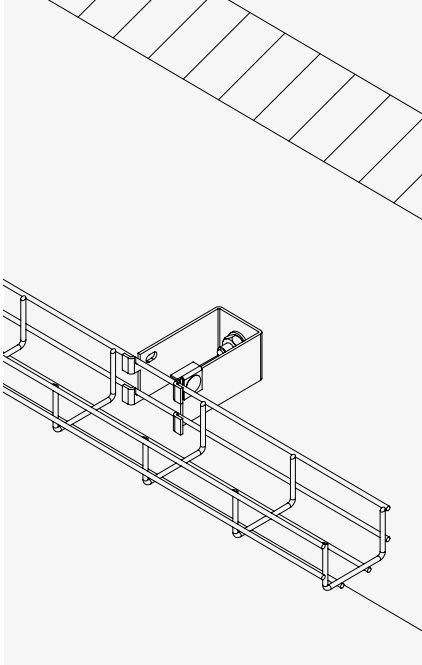

A horizontally aligned U-shaped mesh cable tray mounted on a wall using the GBH 30 spacer bar for 30 mm mesh cable tray.

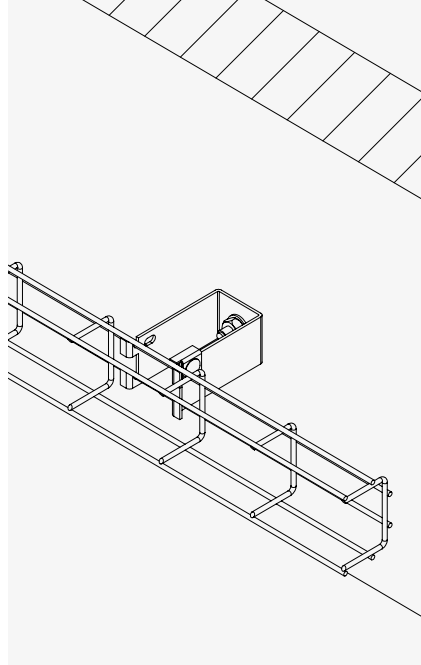

A vertically aligned U-shaped mesh cable tray that is mounted horizontally on a wall using the GBH 30 spacer bar for 30 mm mesh cable trays.

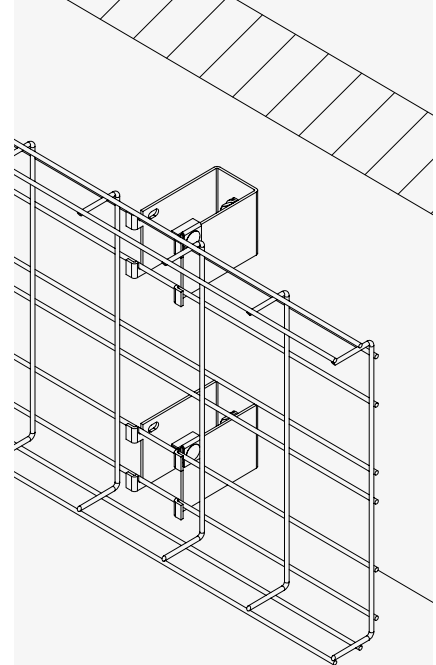

A vertically aligned U-shaped mesh cable tray that is mounted horizontally on a wall using the GBH 50 spacer bar for 50 mm mesh cable trays.

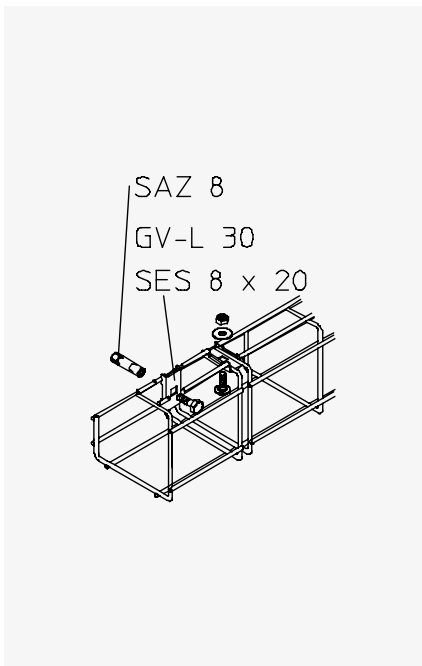

A G-shaped mesh cable tray mounted on a wall using the GV-L 30 mesh cable tray connector set.

## Ceiling mounting

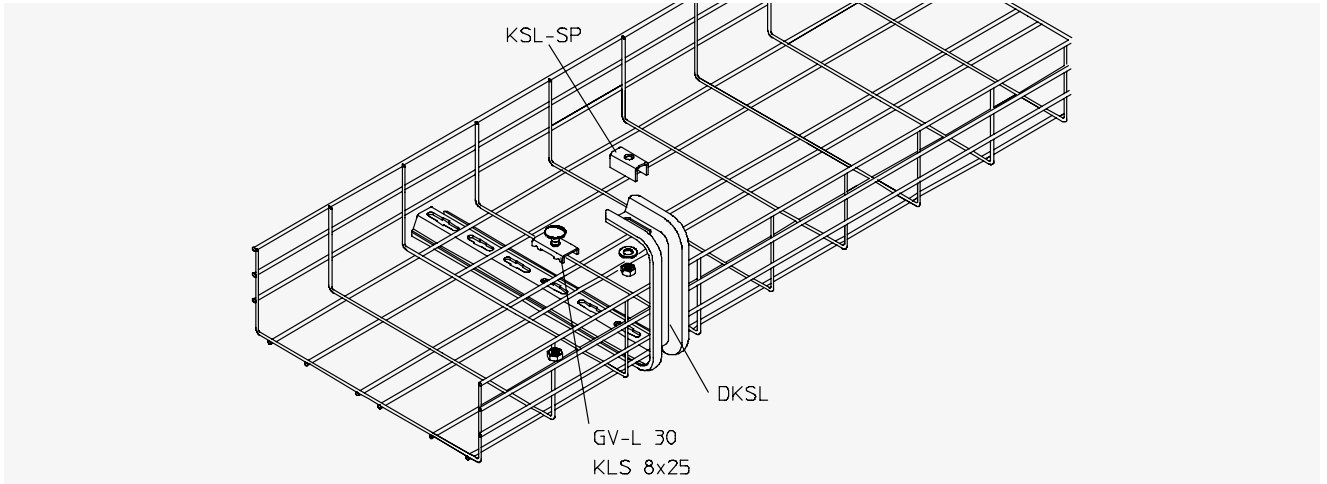

A U-shaped mesh cable tray mounted on a ceiling using the DKSL lightweight ceiling bracket and the GV-L 30 mesh cable tray connector set.

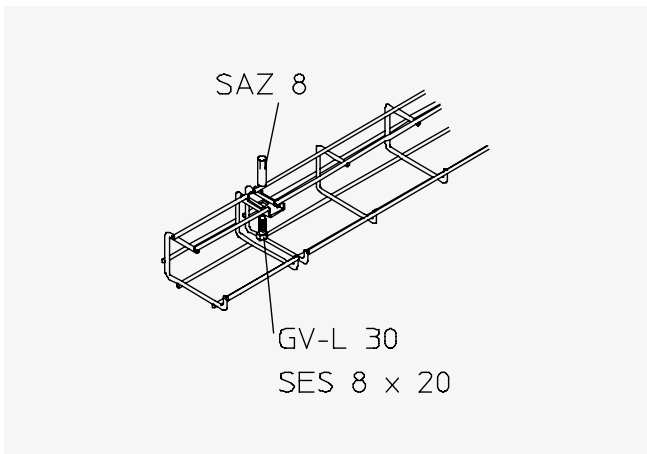

A G-shaped mesh cable tray mounted on a ceiling using the GV-L 30 mesh cable tray connector set.

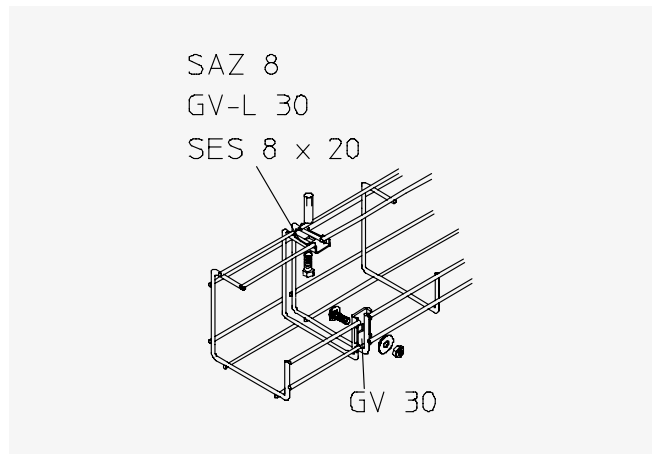

A G-shaped mesh cable tray mounted on a ceiling using the GV-L 30 mesh cable tray connector set.

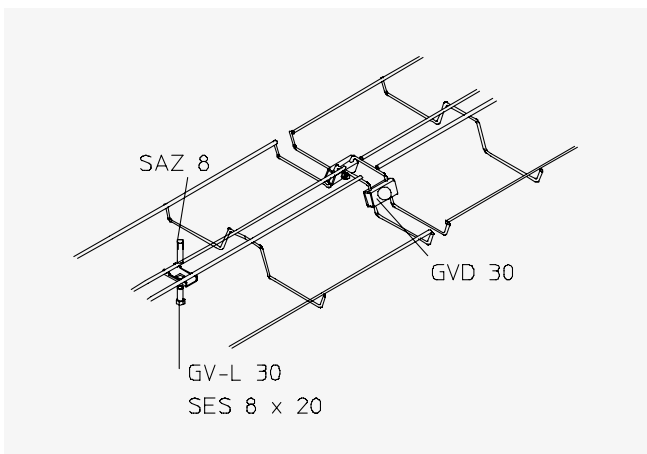

A W-shaped mesh cable tray mounted on a ceiling using the GV-L 30 mesh cable tray connector set.

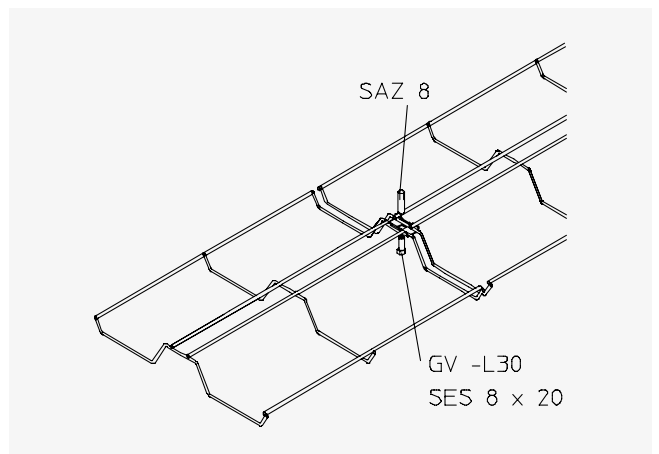

A W-shaped mesh cable tray mounted on a ceiling using the GV-L 30 mesh cable tray connector set.

## Steel beam mounting

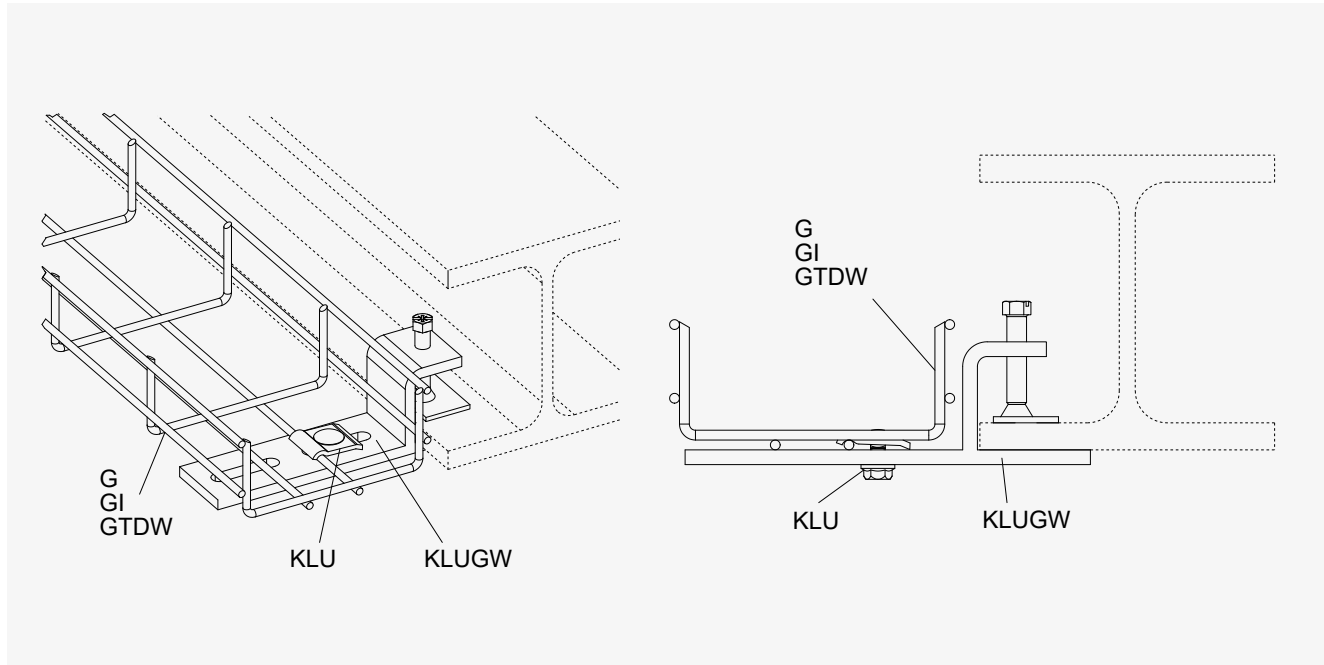

A horizontally aligned U-shaped mesh cable tray mounted on a steel beam using the KLUGW fastening clamp set and the KLU clamp fastening set.

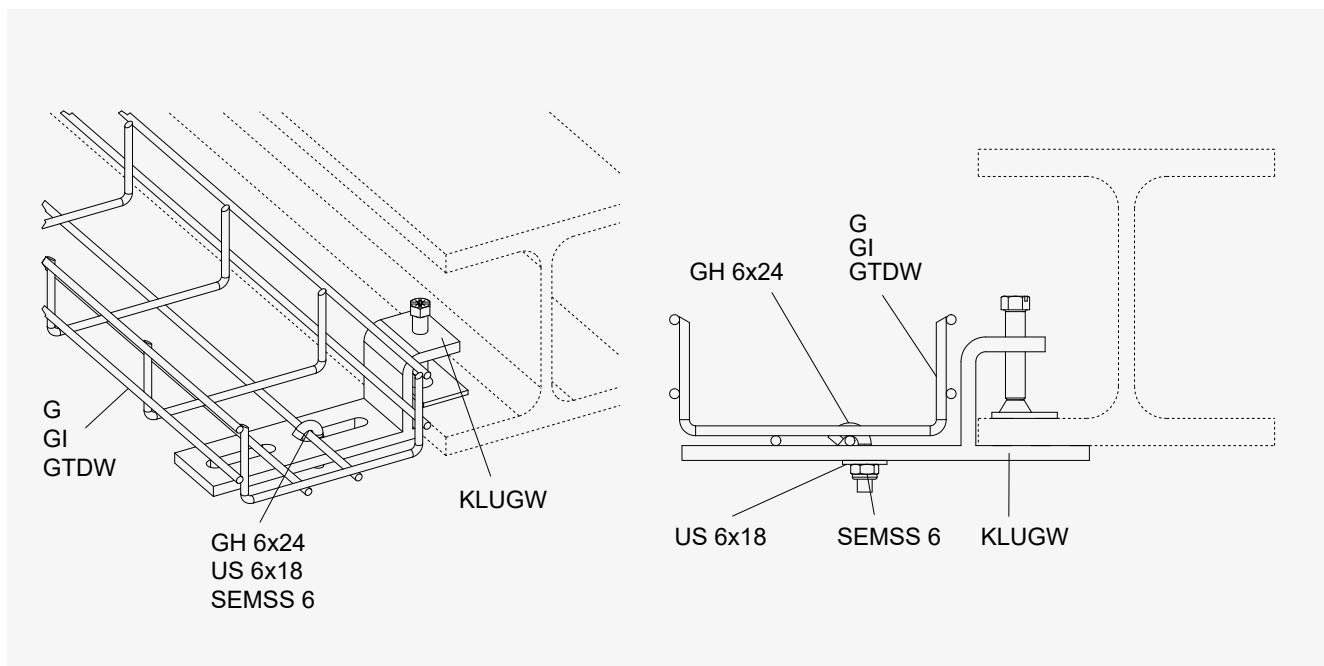

A horizontally aligned U-shaped mesh cable tray mounted on a steel beam using the KLUGW fastening clamp set and a bolt set comprising the GH fastening hook, a standard US DIN 125 washer and a standard SEMSS DIN 985 self-locking hexagon nut.

## Steel beam mounting

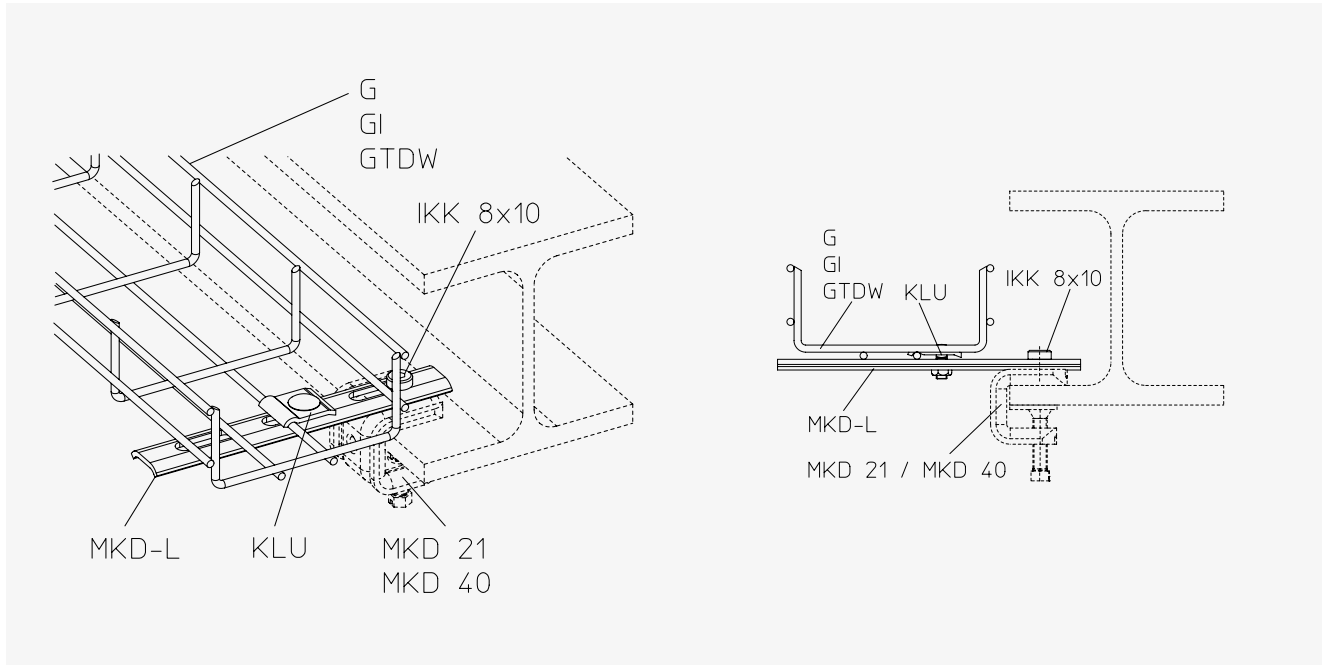

A horizontally aligned U-shaped mesh cable tray mounted on a steel beam using an MKD-L mounting link and MKD mounting clamp connected via a hexagon socket head screw standardised to DIN 7984 (IKK) and the KLU clamp fastening set.

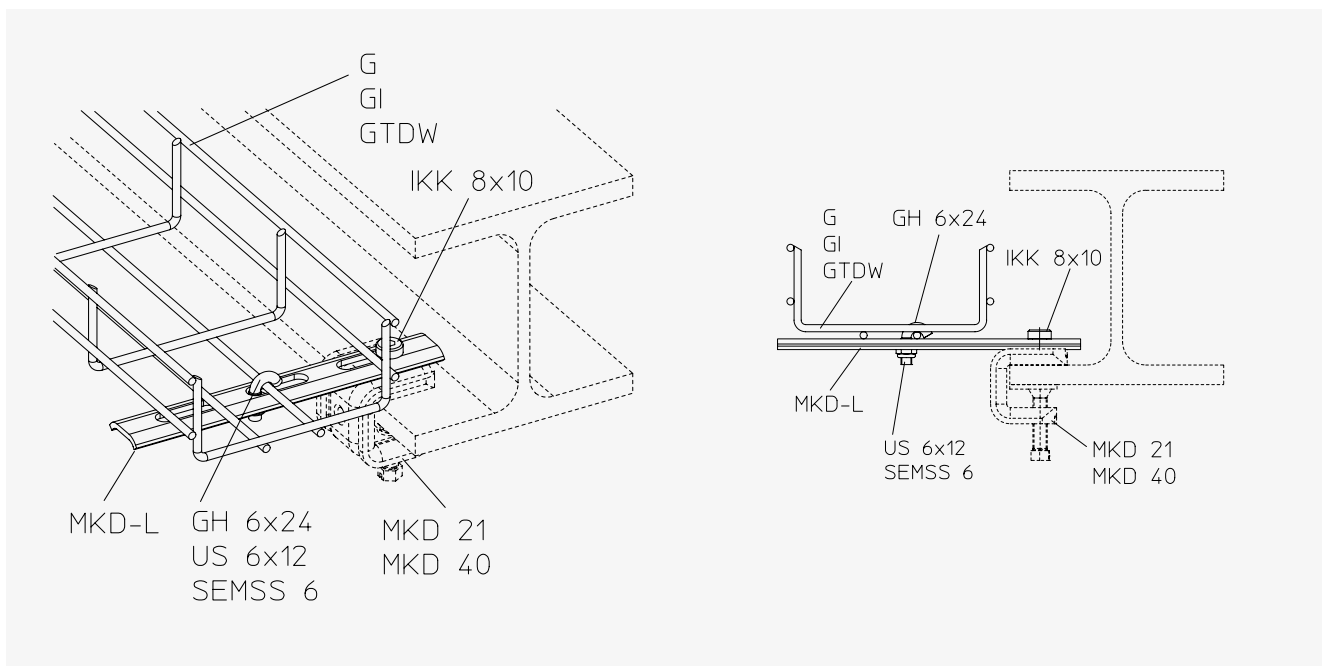

A horizontally aligned U-shaped mesh cable tray mounted on a steel beam using an MKD-L mounting link and MKD mounting clamp connected via a hexagon socket head screw standardised to DIN 7984 (IKK) and a bolt set comprising the GH fastening hook, a washer standardised to DIN 125 US (DIN 125) and a self-locking hexagon nut standardised to DIN 985 (SEMSS DIN 985).

## Steel beam mounting

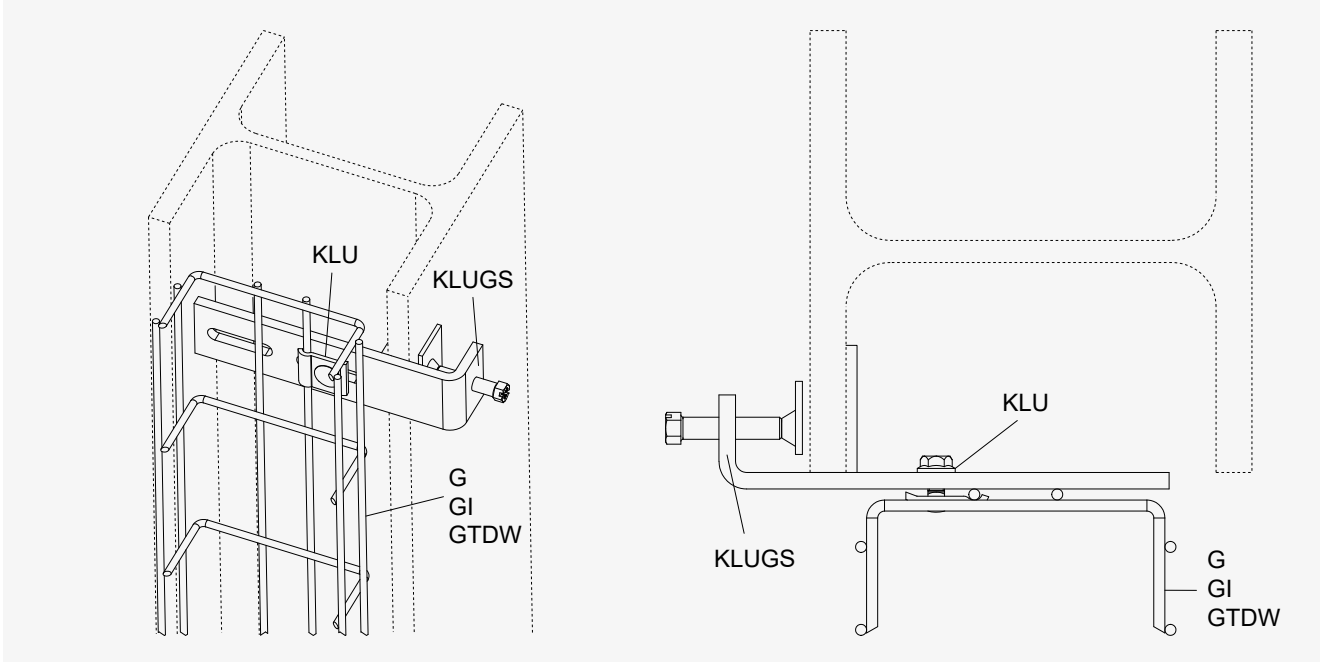

A vertically aligned U-shaped mesh cable tray mounted on a steel beam using the KLUGS fastening clamp set and the KLU clamp fastening set.

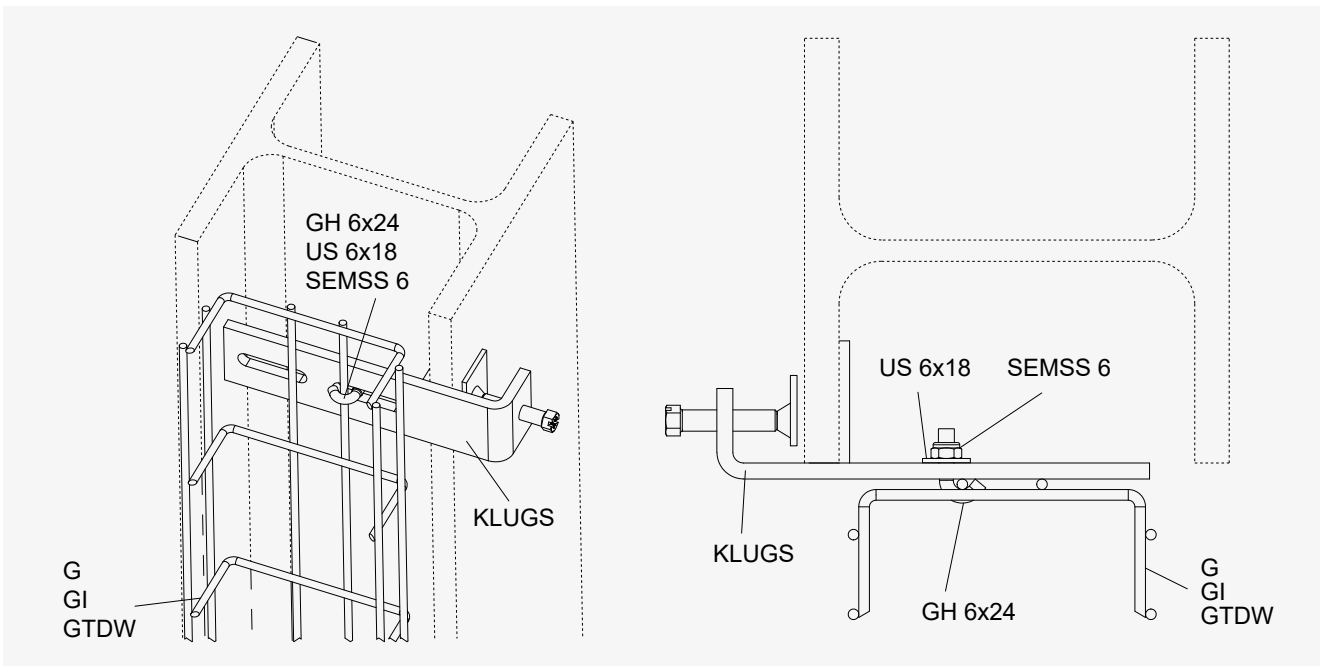

A vertically aligned U-shaped mesh cable tray mounted on a steel beam using the KLUGS fastening clamp set and a bolt set comprising the GH fastening hook, a washer standardised to DIN 125 and a self-locking hexagon nut standardised to DIN 985.

## Steel beam mounting

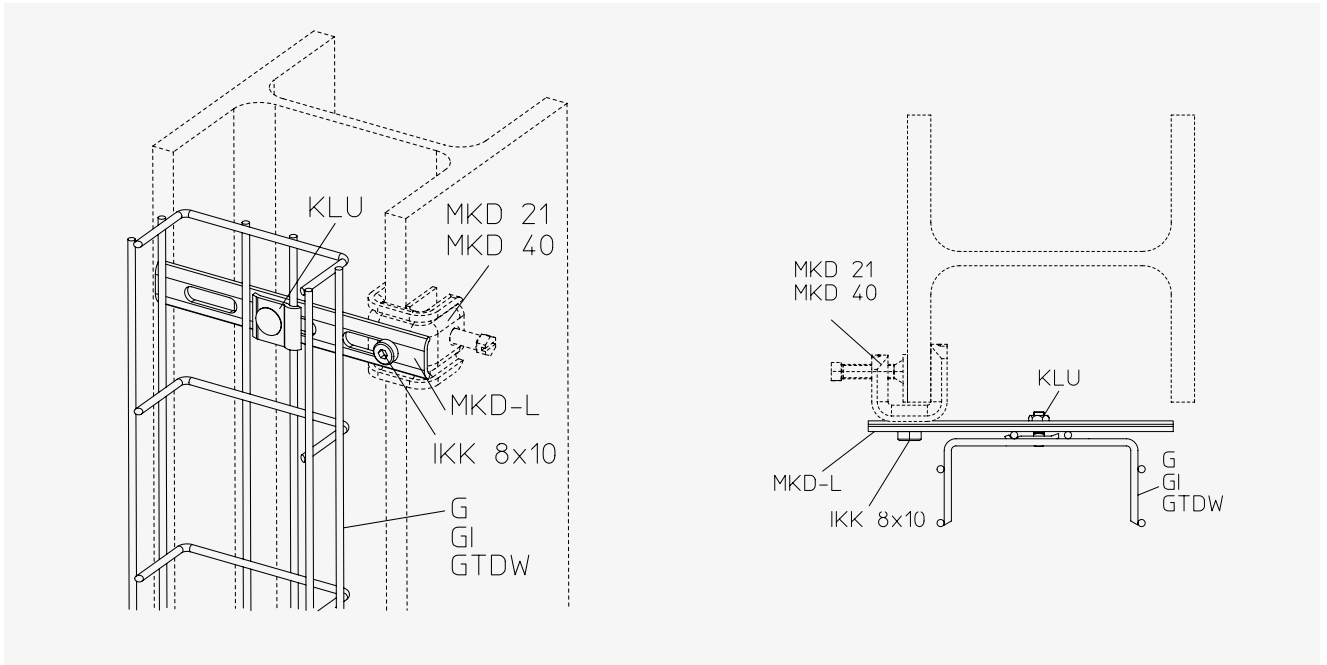

A vertically aligned U-shaped mesh cable tray mounted on a steel beam using an MKD-L mounting link and MKD mounting clamp connected via a hexagon socket head screw standardised to DIN 7984 (IKK) and the KLU clamp fastening set.

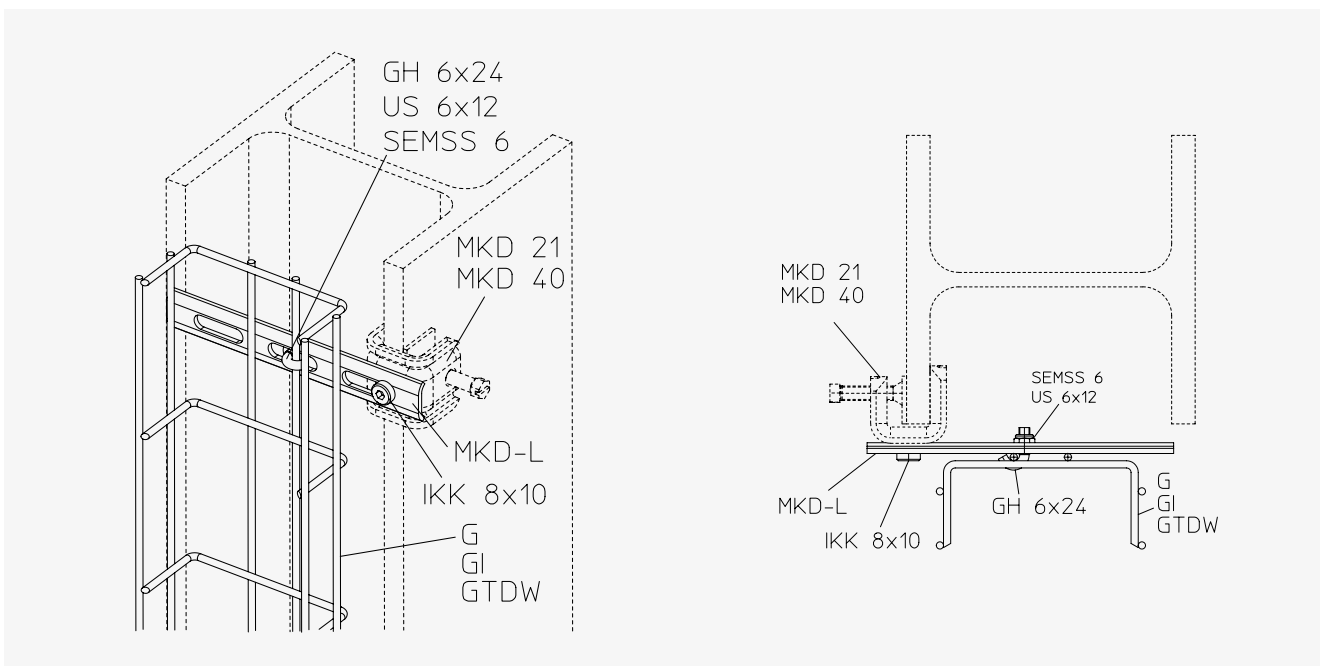

A vertically aligned U-shaped mesh cable tray mounted on a steel beam using an MKD-L mounting link and MKD mounting clamp connected via a hexagon socket head screw standardised to DIN 7984 (IKK) and a bolt set comprising the GH fastening hook, a washer standardised to DIN 125 US (DIN 125) and a self-locking hexagon nut standardised to DIN 985 (SEMSS DIN 985).

## Special configurations

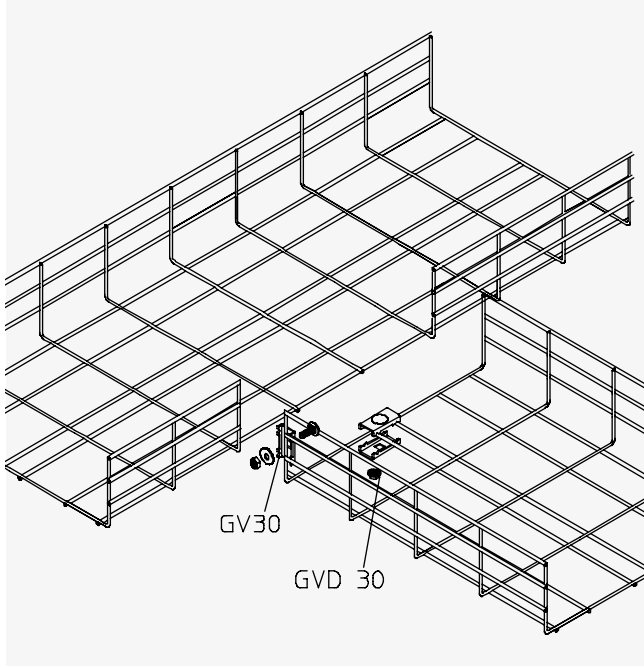

A mesh cable tray branch produced using a U-shaped mesh cable tray using the GVD 30 mesh cable tray connector set and the GV 30 mesh cable tray connector set.

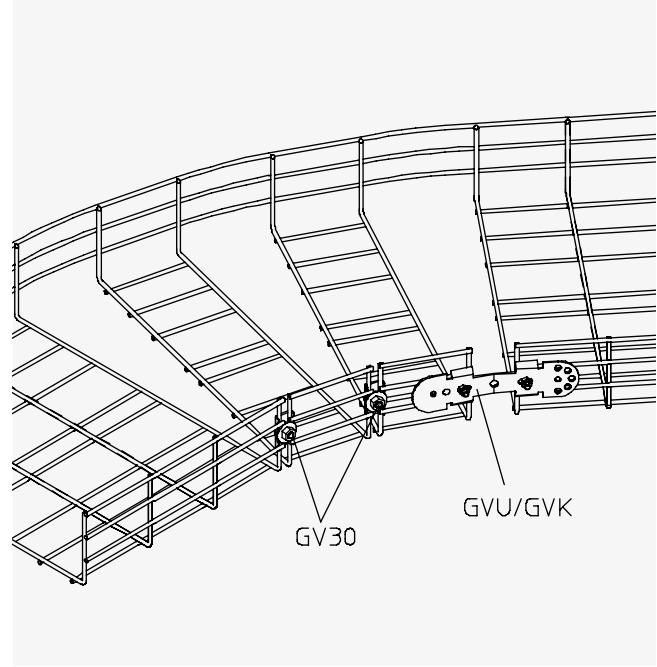

A mesh cable tray bend using a U-shaped mesh cable tray using the GV 30 mesh cable tray connector set, the GVU mesh cable tray connector and the GVK mesh cable tray connector clamp.

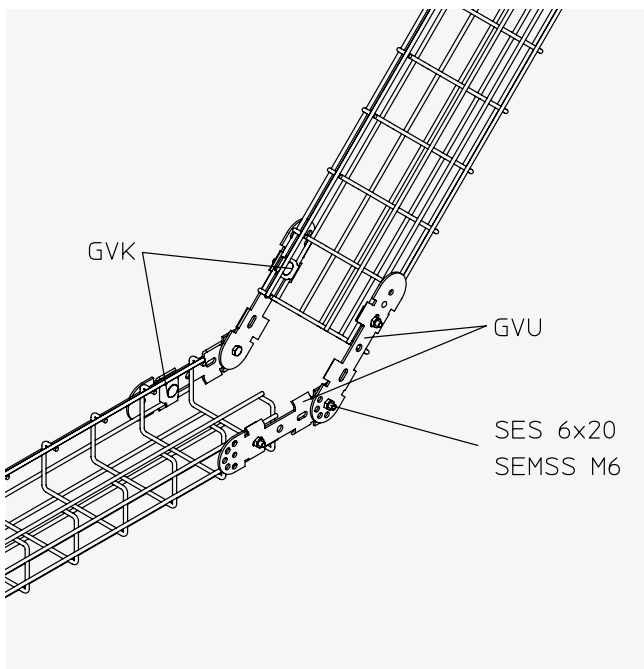

A vertical change of direction configured on a U-shaped mesh cable tray using the GVU mesh cable tray connector and the GVK mesh cable tray connector clamp.

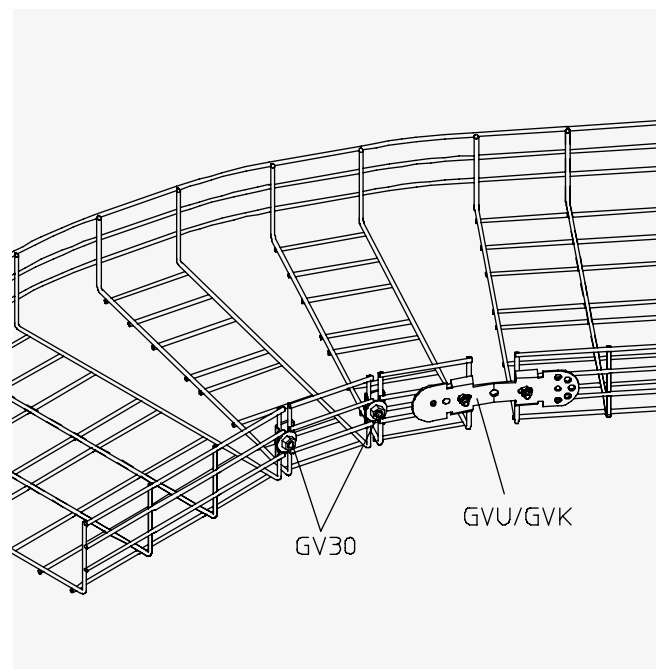

A mesh cable tray bend using a U-shaped mesh cable tray using the GV 30 mesh cable tray connector set, the GVU mesh cable tray connector and the GVK mesh cable tray connector clamp.

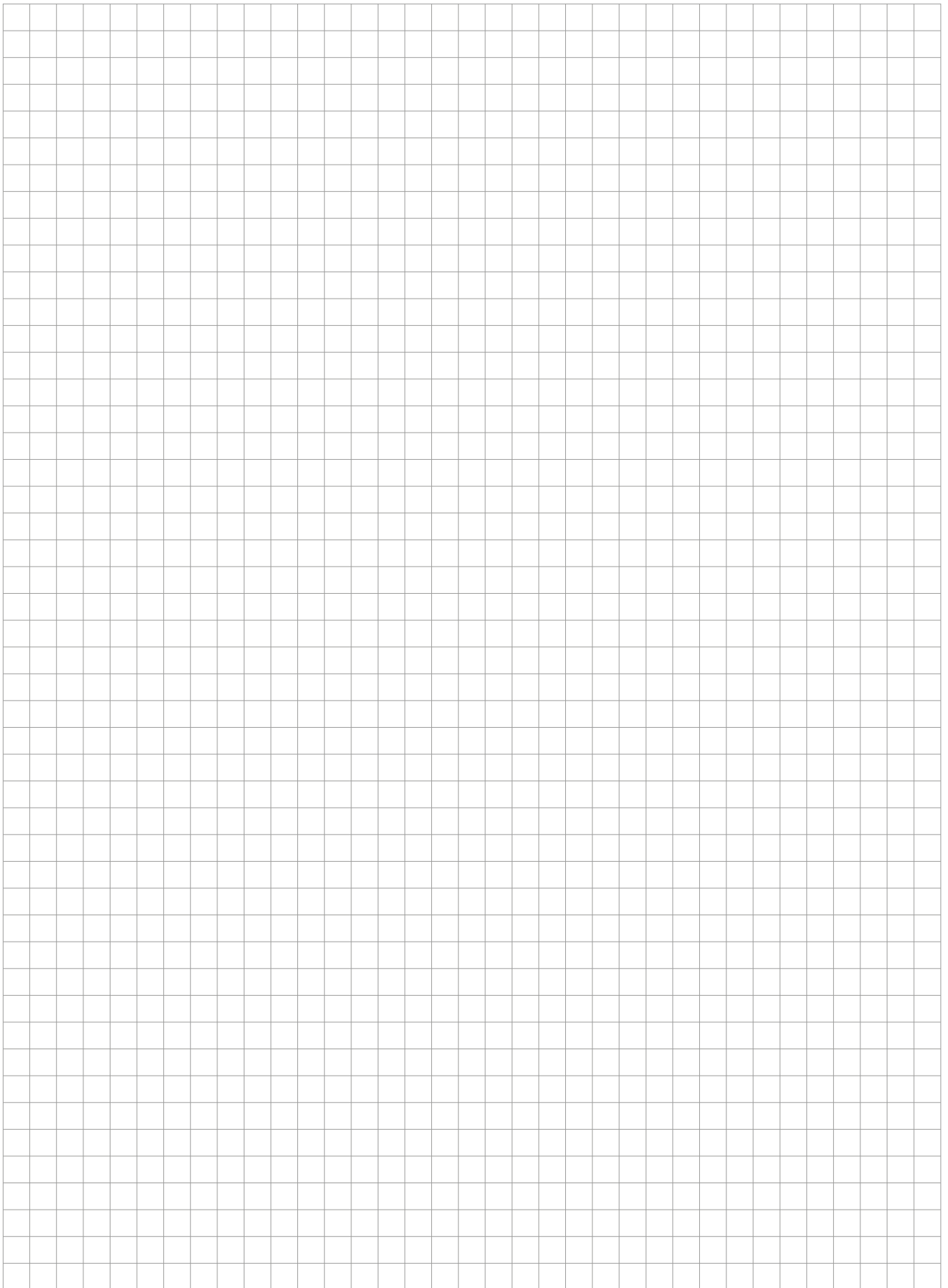

# Our synergy concept for your benefit

**With us, you can take advantage of the collective experience of three established manufacturers that combine products and expertise in one comprehensive offer. That is the PohlCon synergy concept.**



## **Full service consulting**

Our extensive network of consultants is available to answer all of your questions about our products on site. From planning to deployments, enjoy personal support from our qualified professionals.



## **Digital solutions**

Our digital offerings offer targeted support in planning with our products. From tender texts through CAD details and BIM data to modern software solutions, we offer you tailored support for your planning.



## **7 areas of application**

We think in holistic solutions, which is why we have grouped our products into seven areas of application for you where you can benefit from the synergy of the PohlCon product portfolio.

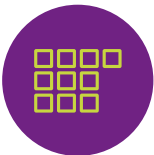

## **10 product categories**

To help you find the right product in our extensive range even faster, the products are grouped into ten product categories so you can navigate clearly between our products.



## **Individual special solutions**

There's no mass produced-product on the market that is suitable for your project? We master extraordinary challenges with the many years of expertise of our three manufacturing brands in the sector of individual solutions, allowing us to realize your unique construction projects together.



All rights reserved. Reprinting and any electronic reproduction only authorised with our written permission. Errors excepted and subject to technical changes. No liability can be accepted by the publisher on any legal basis whatsoever. This publication supersedes all previous versions of the document, thereby rendering them invalid.

**PohlCon GmbH**

Nobelstr. 51  
12057 Berlin  
Germany

T +49 30 68283-04  
F +49 30 68283-383

[www.pohlcon.com](http://www.pohlcon.com)