

WPHS-K

flange mounting clamp (brackets)

This article is available made in material No. 1.4571/1.4404 (V4A) stainless steel finish.

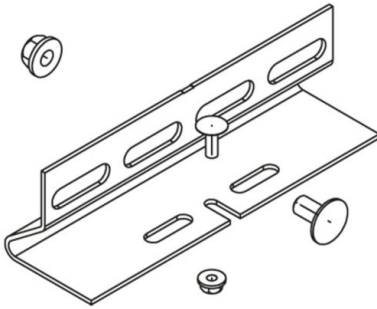

Continuously hot galvanized (Sendzimir process) (DIN EN 10346)

Product	G
WPHS-K S	0,51 kg
incl.:	
1x KLS 10X20	clamp fastening set round-head screw with short square, DIN 603 hexagon-nut with flange, DIN EN 1661
1x FRSV 6X16	
1x SEMS 6	

Hot-dip galvanized, according to BS 729 (DIN EN ISO 1461)

Product	G
WPHS-K F	0,55 kg
incl.:	
1x KLS 10X20F	clamp fastening set round-head screw with short square, DIN 603 hexagon-nut with flange, DIN EN 1661
1x FRSV 6X16E	
1x SEMS 6E	

Stainless steel, according to ASTM 304 / BS 304 S 3

Product	G
WPHS-K E	0,51 kg



Product

G

incl.:

1x KLS 10X20E
1x FRSV 6X16E
1x SEMS 6E

clamp fastening set
round-head screw with short square, DIN 603
hexagon-nut with flange, DIN EN 1661

G: weight

OPTIONAL ACCESSORIES

WPHS-IS

