

WPHS-A

flange mounting clamp (C-profiles)

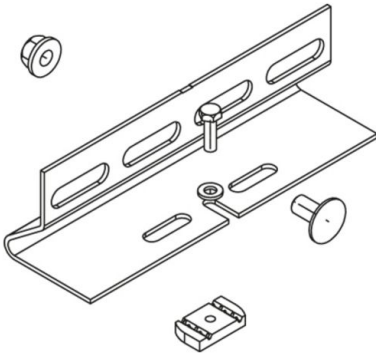

Continuously hot galvanized (Sendzimir process) (DIN EN 10346)

Product	G
WPHS-A S	0,53 kg
incl.:	
1x SES 6X20	hexagon head bolt, DIN 933
1x AM22 M6	channel nut, A 41, KHA 41, KHAL 41
1x KLS 10X20	clamp fastening set

Hot-dip galvanized, according to BS 729 (DIN EN ISO 1461)

Product	G
WPHS-A F	0,57 kg
incl.:	
1x KLS 10X20F	clamp fastening set
1x SES 6X20E	hexagon head bolt, DIN 933
1x AM22 M6F	channel nut, A 41, KHA 41, KHAL 41

Stainless steel, according to ASTM 304 / BS 304 S 3

Product	G
WPHS-A E	0,53 kg



Product

G

incl.:

1x SES 6X20E
1x AM22 M6E4
1x KLS 10X20E

hexagon head bolt, DIN 933
channel nut, A 41, KHA 41, KHAL 41
clamp fastening set

G: weight

OPTIONAL ACCESSORIES

WPHS-IS

