

## WPD-A

cover elevator

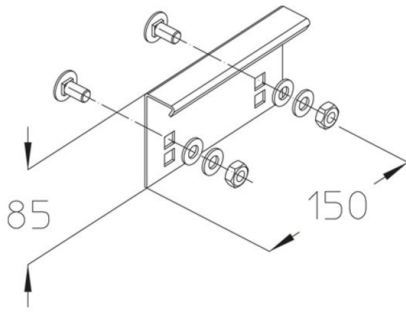

Cover elevator for the elevation of wide-span tray covers (6 WPD-A/3m). The covers must be secured with cover clips at a distance of 100 mm from the cover ends and in the middle (6 WPDUK/3m). In wind-exposed areas, the number must be increased to at least ten WPD-A and WPDUK per 3m. In the interior, securing with cover clips is optional. The filling volume of the route remains unchanged.

Continuously hot galvanized (Sendzimir process) (DIN EN 10346)

Product	H	B	G
WPD-A S	85 mm	150 mm	0,35 kg
incl.:			
2x UVS M10-PE		captive washer	
2x KLS 10X20		clamp fastening set	
2x UVS M10		captive washer	

Hot-dip galvanized, according to BS 729 (DIN EN ISO 1461)

Product	H	B	G
WPD-A F	85 mm	150 mm	0,35 kg
incl.:			
2x KLS 10X20F		clamp fastening set	
2x UVS M10		captive washer	

Stainless steel, according to ASTM 304 / BS 304 S 3

Product	H	B	G
WPD-A E	85 mm	150 mm	0,35 kg



Product	H	B	G
incl. 2x UVS M10-PE 2x KLS 10X20E 2x UVS M10		captive washer clamp fastening set captive washer	

---

**H:** height  
**B:** width  
**G:** weight

