

## W

cable clamp for wall fastening Maintenance of function - Standard support structures

cable clamp, hot-dip galvanized, for fastening directly to walls

The products can be used for fire protection. For technical parameters, see National Technical Test Certificates (abPs).

### Zinc coated

Product	D	M	G
16 W	12-16 mm	2 Nm	4,4 kg/100
20 W	16-20 mm	2 Nm	5,4 kg/100
24 W	20-24 mm	2 Nm	5,8 kg/100
28 W	24-28 mm	2 Nm	6,3 kg/100
32 W	28-32 mm	4 Nm	8,5 kg/100
36 W	32-36 mm	4 Nm	9,1 kg/100
44 W	36-44 mm	4 Nm	13,5 kg/100
52 W	44-52 mm	4 Nm	16,5 kg/100
60 W	52-60 mm	4 Nm	19,5 kg/100

**D:** diameter

**M:** torque

**G:** weight

## DETAILS / APPLICATIONS



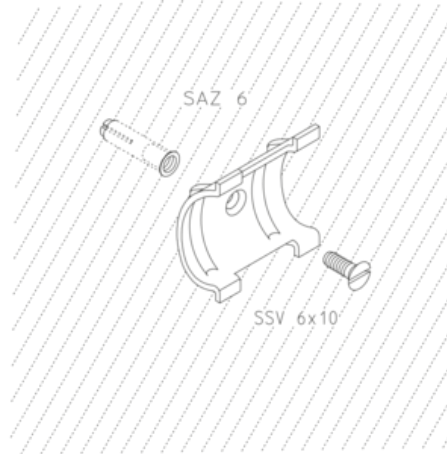
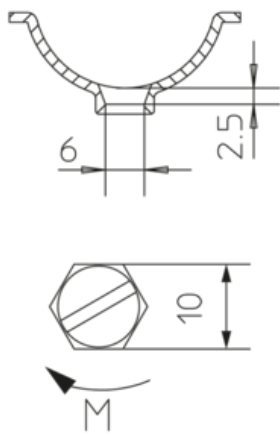

## OPTIONAL ACCESSORIES

SSV, LW, SAZ

