

UK

screed-covered duct, 2-compartment

2-compartment duct as a closed rectangular profile made of Sendzimir hot-dip galvanized sheet steel with a separating strip. Top and bottom piece are firmly connected with each other and have integrated drillings in the side seam.

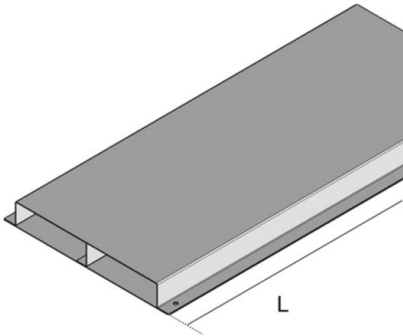

material	sheet steel, hot-dip galvanized
type of assembly	Mounting on raw concrete ceiling
application area	screed-covered duct system
norm	according to DIN EN 50085
permits	according to VDE / TÜV

Continuously hot galvanized (Sendzimir process) (DIN EN 10346)

Product	H	B	B1	B2	L	P _{max}	G
UK 2-28-190S	28 mm	190 mm	95 mm	95 mm	3000 mm	0,75 kN	15,5 kg
UK 2-28-250S	28 mm	250 mm	125 mm	125 mm	3000 mm	0,75 kN	19 kg
UK 2-28-350S	28 mm	350 mm	175 mm	175 mm	3000 mm	0,75 kN	24,7 kg
UK 2-38-190S	38 mm	190 mm	95 mm	95 mm	3000 mm	0,75 kN	16,5 kg
UK 2-38-250S	38 mm	250 mm	125 mm	125 mm	3000 mm	0,75 kN	19,8 kg
UK 2-38-350S	38 mm	350 mm	175 mm	175 mm	3000 mm	0,75 kN	25,5 kg
UK 2-48-190S	48 mm	190 mm	95 mm	95 mm	3000 mm	0,75 kN	17,3 kg
UK 2-48-250S	48 mm	250 mm	125 mm	125 mm	3000 mm	0,75 kN	20,7 kg
UK 2-48-350S	48 mm	350 mm	175 mm	175 mm	3000 mm	0,75 kN	26,8 kg

H: height
 B: width
 B1: width
 B2: width



L: length
P_{max}: Maximum load
G: weight

DETAILS / APPLICATIONS

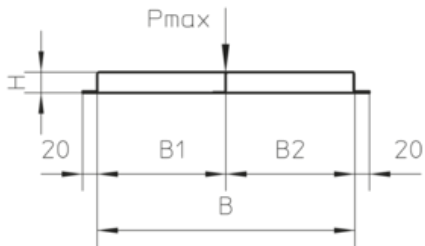

OPTIONAL ACCESSORIES

UB, UGKB, UN

