

## UEBS

### screed-flush duct, 1-compartment

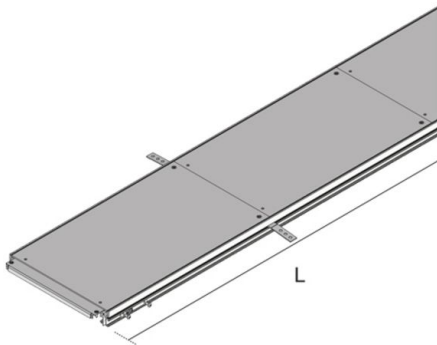

Screed-flush duct, open system with removable covers for the horizontal duct course. Consisting of pre-assembled aluminium side profiles with rubber seal, dummy covers made of steel sheet, cross beams, screed anchors and carpet profiles. Can be separated using separating strips. As basic version in the systems steel sheet side profiles, plastic side profile for the impact sound decoupling and as a closed tub for the laying of EMV cables. Suitable for rooms with dry and damp-cleaned floor covers. Designed for office traffic loads.

Screed-flush duct system consisting of 1x duct UEBS and optional accessories, 2x side panels UEBSMSP, respectively 1x tub UEBSMSW and 4x levelling units UEBSST.

material	Cover: sheet steel, hot-dip galvanized, side profiles: aluminium
type of assembly	Mounting on raw concrete ceiling
application area	dry and damp-cleaned floor covers
norm	according to DIN EN 50085
permits	according to VDE / TÜV
loading	including inspection stamp Ø 13 / 130 mm: 2 / 3 kN

### Continuously hot galvanized (Sendzimir process) (DIN EN 10346)

Product	H <sub>min</sub>	N	B	L	E	t	P <sub>max</sub>	IP <sub>n</sub>	G
UEBS 20S	60 mm	90 mm	200 mm	2000 mm	400 mm	3,00 mm	3 kN	IP 30	15,14 kg
incl.:									
2x UEBSPT-3 AL				carpet flange with hem 0/3 mm					
1x UEBSE				earthing connector					
4x UEBSEA				screed anchor					
4x UEBSD 20S				dummy cover					
UEBS 30S	60 mm	90 mm	300 mm	2000 mm	500 mm	3,00 mm	3 kN	IP 30	20,30 kg
incl.:									
2x UEBSPT-3 AL				carpet flange with hem 0/3 mm					
1x UEBSE				earthing connector					
4x UEBSEA				screed anchor					
4x UEBSD 30S				dummy cover					
UEBS 40S	60 mm	90 mm	400 mm	2000 mm	600 mm	3,00 mm	3 kN	IP 30	25,46 kg



Product	$H_{min}$	N	B	L	E	t	$P_{max}$	$IP_n$	G
incl.:									
2x UEBSPT-3 AL									carpet flange with hem 0/3 mm
1x UEBSE									earthing connector
4x UEBSEA									screed anchor
4x UEBSD 40S									dummy cover
UEBS 50S	60 mm	90 mm	500 mm	2000 mm	700 mm	3,00 mm	3 kN	IP 30	30,86 kg
incl.:									
2x UEBSPT-3 AL									carpet flange with hem 0/3 mm
1x UEBSE									earthing connector
4x UEBSEA									screed anchor
4x UEBSD 50S									dummy cover

$H_{min}$ : Minimum installation height

**N**: levelling range

**B**: width

**L**: length

**E**: fitting dimension

**t**: material thickness

$P_{max}$ : Maximum load

$IP_n$ : IP protection level in unused condition

**G**: weight

## DETAILS / APPLICATIONS

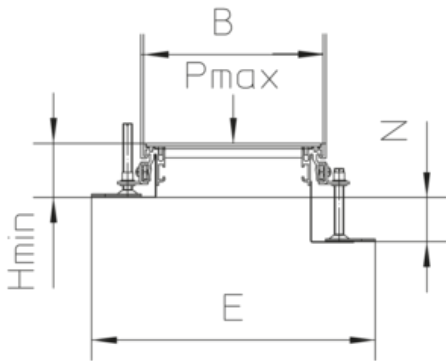

## OPTIONAL ACCESSORIES

UEBSMSP S, UEBSMSP, UEBSMSW, UEBSST, UEBSQT, UEBSQT S, UEBSQTF S



