

UEBDS R E

stainless steel heavy-duty dummy cover unit, triple, round

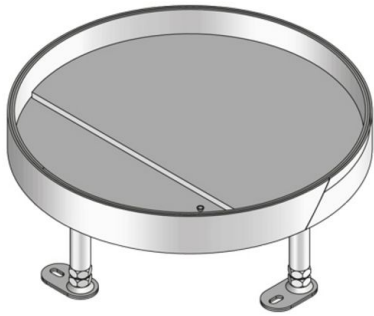

Round cartridge made of stainless steel panel with a hem. As a levellable cartridge mounting frame with dummy and heavy-duty cartridge and rubber seal for the mounting into floor boxes, assembly covers and double or hollow floor openings. Suitable for floors with wet-cleaned floors. For higher traffic loads.

Please mind the technical information in chapter planning.



material	cartridge and frame: 2mm high-grade steel V2A, bottom plate: 3mm high-grade steel V2A, heavy-duty inlay: hot dip galvanized steel panel, tube mounting set: anodized aluminium
type of assembly	To be mounted in floor box UBDHB respectively hollow floors.
application area	wet floor cleaning
protection class	not in use IP 54
norm	according to DIN EN 50085
permits	according to VDE / TÜV
loading	including inspection stamp Ø 130 mm: 20 kN

Stainless steel, according to ASTM 304 / BS 304 S 3

Product	H	H _{min}	N	B	E	T	P _{max}	IP _n	G
UEBDS 35-R6 E	38 mm	117 mm	55 mm	305 mm	307 mm	24 mm	20 kN	IP 54	6,93 kg
incl.:									
1x UGEAR-ELS				grounding angle bracket					
1x UGD-R 10-2				rubber seal, round					
1x UGDB15-R300 1.8				rubber seal, round					

H: height

H_{min}: Minimum installation height

N: levelling range

B: width

E: fitting dimension

T: depth

P_{max}: Maximum load



IP_n: IP protection level in unused condition
G: weight

DETAILS / APPLICATIONS

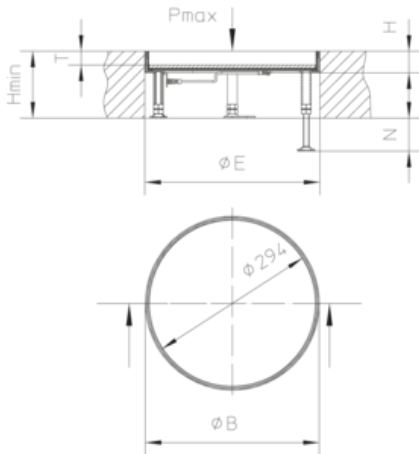

OPTIONAL ACCESSORIES

UBDSLFL, UGM SLF



wet-cleaned

