

## UEBDM R WD

stainless steel tube cover unit, triple, round

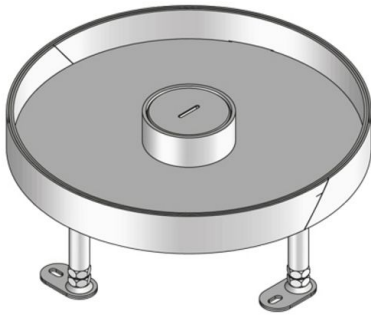

Round cartridge made of stainless steel sheet with hem. As a levellable cartridge installation frame with a tube outlet cartridge, a screwed-on aluminum tube mounting set and a rubber seal for the installation into floor boxes, assembly covers and raised or hollow floor openings. To accommodate up to 3 mounting boxes equipped with up to 9 suspension bracket installation devices or 12 installation devices of 45x45 mm. Suitable for rooms with wet-cleaned floor covers. Designed for office traffic loads.

Please mind the technical information in chapter planning.



material	cartridge and frame: 2mm high-grade steel V2A, bottom plate: 3mm high-grade steel V2A, tube mounting set: anodized aluminium
type of assembly	To be mounted in floor box UBDHB respectively hollow floors.
application area	wet floor cleaning
protection class	in use IP 22 / not in use IP 54
norm	according to DIN EN 50085
permits	according to VDE / TÜV
loading	including inspection stamp Ø 13 / 130 mm: 2 / 3 kN

### Aluminium

Product	H	H <sub>min</sub>	N	B	E	T	P <sub>max</sub>	IP <sub>n</sub>	IP <sub>g</sub>	G
UEBDM 15-R-WD	21 mm	100 mm	55 mm	305 mm	307 mm	12 mm	2 kN	IP 54	IP 22	3,2 kg
incl.:										
1x UGDB15-R300 1.8					rubber seal, round					
1x UGD-R 10-2					rubber seal, round					
1x UETD-R-WD					tube cover					
UEBDM 35-R-WD	38 mm	117 mm	55 mm	305 mm	307 mm	30 mm	2 kN	IP 54	IP 22	3,82 kg
incl.:										
1x UGDB15-R300 1.8					rubber seal, round					
1x UGD-R 10-2					rubber seal, round					
1x UETD-R-WD					tube cover					

Page 1



**H:** height  
**H<sub>min</sub>:** Minimum installation height  
**N:** levelling range  
**B:** width  
**E:** fitting dimension  
**T:** depth  
**P<sub>max</sub>:** Maximum load  
**IP<sub>n</sub>:** IP protection level in unused condition  
**IP<sub>g</sub>:** IP protection level in used condition  
**G:** weight

## DETAILS / APPLICATIONS

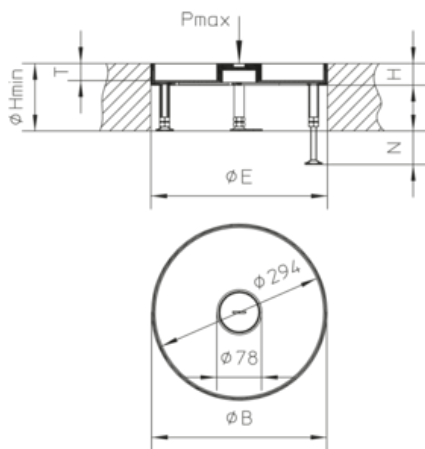

## OPTIONAL ACCESSORIES

UEBDME R, UGEAR, UET WD, UBDSLIF, UGM SLF



wet-cleaned

