

## UEBD R E

stainless steel dummy cover unit, triple, round

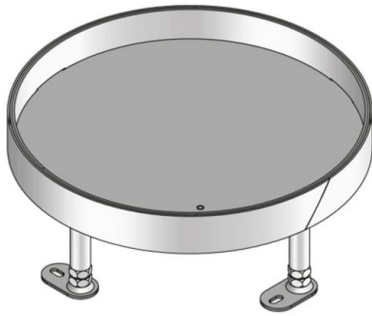

Round cartridge made of stainless steel panel with a hem. As a levelling cartridge installation frame with dummy inlay cartridge and rubber seal for the installation into floor boxes, assembly covers and raised floor or hollow floor openings. Suitable for rooms with wet-cleaned floor covers. Designed for office traffic loads.

Please mind the technical information in chapter planning.



material	cartridge and frame: 2mm high-grade steel V2A, bottom plate: 3mm high-grade steel V2A
type of assembly	To be mounted in floor box UBDHB respectively hollow floors.
application area	wet floor cleaning
protection class	not in use IP 54
norm	according to DIN EN 50085
permits	according to VDE / TÜV
loading	including inspection stamp Ø 13 / 130 mm: 2 / 3 kN

### Stainless steel, according to ASTM 304 / BS 304 S 3

Product	H	H <sub>min</sub>	N	B	E	T	P <sub>max</sub>	IP <sub>n</sub>	G
UEBD 15-R E	21 mm	100 mm	55 mm	305 mm	307 mm	12 mm	2 kN	IP 54	3,14 kg
incl.:									
1x UGEAR-ELS				grounding angle bracket					
1x UGD-R 10-2				rubber seal, round					
1x UGDB15-R300 1.8				rubber seal, round					
UEBD 35-R E	38 mm	117 mm	55 mm	305 mm	307 mm	30 mm	2 kN	IP 54	3,67 kg
incl.:									
1x UGEAR-ELS				grounding angle bracket					
1x UGD-R 10-2				rubber seal, round					
1x UGDB15-R300 1.8				rubber seal, round					

H: height

H<sub>min</sub>: Minimum installation height



**N:** levelling range  
**B:** width  
**E:** fitting dimension  
**T:** depth  
**P<sub>max</sub>:** Maximum load  
**IP<sub>n</sub>:** IP protection level in unused condition  
**G:** weight

## DETAILS / APPLICATIONS

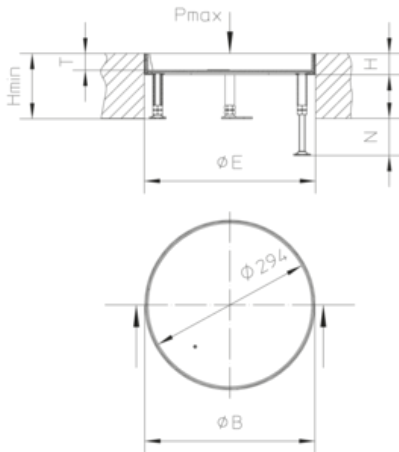

## OPTIONAL ACCESSORIES

UEBDE R, UBDSLFL, UGM SLF



wet-cleaned

