

UBKV connector

Connector made of Sendzimir hot-dip galvanized sheet steel as accessory for heavy-duty screed-flush ducts.

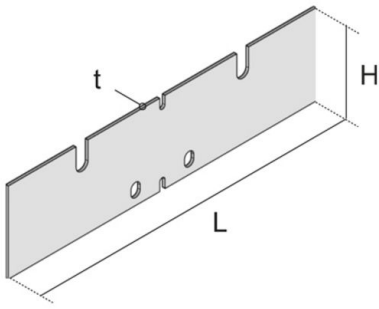

Continuously hot galvanized (Sendzimir process) (DIN EN 10346)

Product	H	L	t	G
UBKV 100S	60 mm	230 mm	2,00 mm	0,21 kg
incl.: 2x FRS 8X25 round-head screw with square, DIN 603 2x SEMS 8 hexagon-nut with flange, DIN EN 1661				
UBKV 135S	95 mm	230 mm	2,00 mm	0,34 kg
incl.: 2x FRS 8X25 round-head screw with square, DIN 603 2x SEMS 8 hexagon-nut with flange, DIN EN 1661				
UBKV 170S	130 mm	230 mm	2,00 mm	0,46 kg
incl.: 2x FRS 8X25 round-head screw with square, DIN 603 2x SEMS 8 hexagon-nut with flange, DIN EN 1661				

H: height
L: length
t: material thickness
G: weight

