

# SKS A

clamping claw, heavy, A/KHA 21/41/42/82

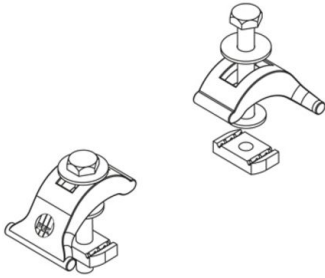

Hot-dip galvanized, according to BS 729 (DIN EN ISO 1461)

Product	k	P <sub>max</sub>	M	G
SKS AF	10 - 30 mm	20 kN	50 Nm	0,56 kg/set
incl.:				
2x SES 10X75F		hexagon head bolt, DIN 933		
2x AM22 M10F		channel nut, A 41, KHA 41, KHAL 41		
2x UVS M10X24		captive washer		

Stainless steel, according to ASTM 31 Ti / AISI 316 L, BS 320S17 / BS 316S11

Product	k	P <sub>max</sub>	M	G
SKS AE4	10 - 30 mm	20 kN	50 Nm	0,59 kg/set
incl.:				
2x SES 10X75E4		hexagon head bolt, DIN 933		
2x UVS M10X24		captive washer		
2x AM22 M10E4		channel nut, A 41, KHA 41, KHAL 41		

**k:** clamping range  
**P<sub>max</sub>:** Maximum load  
**M:** torque  
**G:** weight



## DETAILS / APPLICATIONS

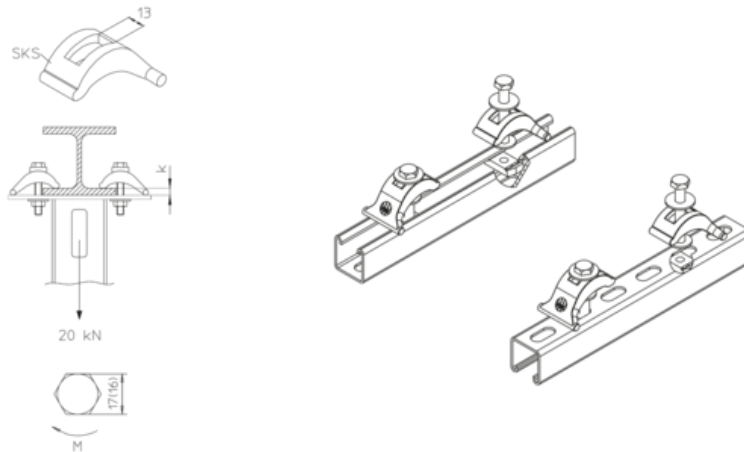

## OPTIONAL ACCESSORIES

A 41, KHA 41

