

## SKL M

beam clamp set

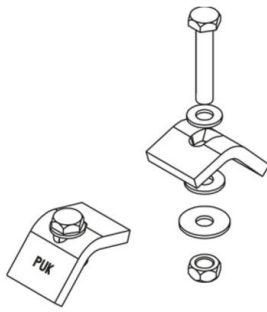

Hot-dip galvanized, according to BS 729 (DIN EN ISO 1461)

Product	k	P <sub>max</sub>	M	G
SKL MF	5 - 25 mm	10 kN	35 Nm	0,45 kg/set
incl.:				
2x SES 10X55F		hexagon head bolt, DIN 933		
2x SEM 10F		hexagon-nut, DIN 934		
2x UVS M10X24		captive washer		

Stainless steel, according to ASTM 31 Ti / AISI 316 L, BS 320S17 / BS 316S11

Product	k	P <sub>max</sub>	M	G
SKL ME4	5 - 25 mm	10 kN	35 Nm	0,46 kg/set
incl.:				
2x SES 10X55E4		hexagon head bolt, DIN 933		
2x SEM 10E4		hexagon-nut, DIN 934		
2x UVS M10X24		captive washer		

**k:** clamping range  
**P<sub>max</sub>:** Maximum load  
**M:** torque  
**G:** weight



## DETAILS / APPLICATIONS

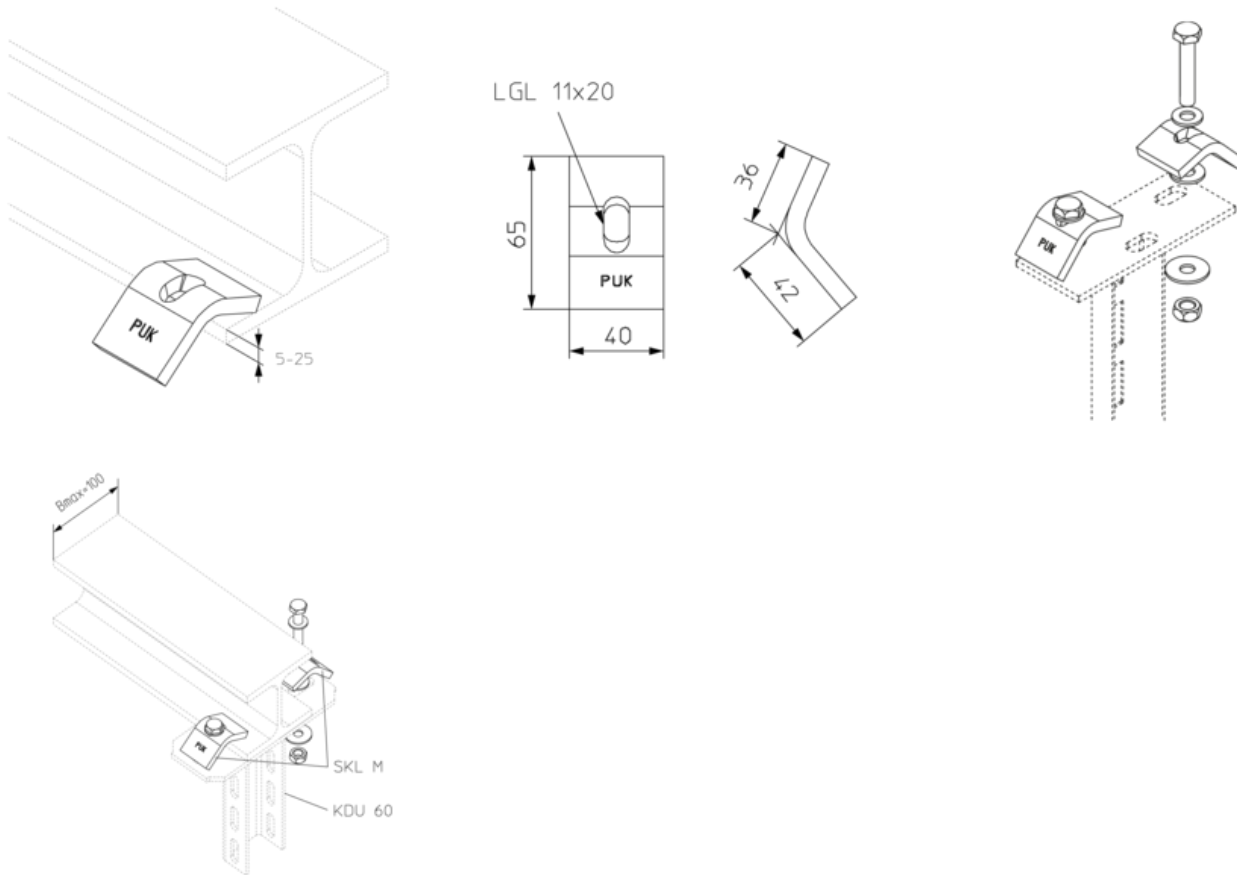

## OPTIONAL ACCESSORIES

KDU 60, KDU 60, KDU 60, KHA 2, HS22

