

KWS

Wall/handle bracket, heavy

Wall/handle bracket, heavy-duty version, with welded-on back plate. Certified according to DIN EN 61537. For mounting on walls or hanging struts.

F_D/P : coefficient for calculation of the dowel load F_D with effective bracket load P respectively the sum of effective bracket loads. The load specifications are only valid with sufficient anchoring to the load-bearing substrate or with proper installation on hanging struts.

Hot-dip galvanized, according to BS 729 (DIN EN ISO 1461)

Product	H	B1	B2	L	P_{max}	F_D/P	G
KWS 020F	215 mm	200 mm	270 mm	290 mm	7,0 kN	1,31	2,04 kg
KWS 030F	215 mm	300 mm	370 mm	390 mm	6,7 kN	1,49	2,40 kg
KWS 040F	215 mm	400 mm	470 mm	490 mm	6,5 kN	1,69	2,78 kg
KWS 050F	215 mm	500 mm	570 mm	592 mm	6,3 kN	1,91	2,91 kg
KWS 060F	215 mm	600 mm	670 mm	692 mm	6,1 kN	2,13	3,22 kg
KWS 070F	215 mm	700 mm	770 mm	792 mm	5,2 kN	2,60	3,54 kg
KWS 080F	215 mm	800 mm	870 mm	892 mm	4,4 kN	3,07	3,85 kg
KWS 090F	215 mm	900 mm	970 mm	992 mm	3,6 kN	3,56	4,17 kg
KWS 100F	215 mm	1000 mm	1070 mm	1092 mm	2,8 kN	4,06	4,48 kg

Stainless steel, according to ASTM 304 / BS 304 S 3

Product	H	B1	B2	L	P_{max}	F_D/P	G
KWS 020E	215 mm	200 mm	270 mm	290 mm	7,0 kN	1,31	1,92 kg
KWS 030E	215 mm	300 mm	370 mm	390 mm	6,7 kN	1,49	2,26 kg
KWS 040E	215 mm	400 mm	470 mm	490 mm	6,5 kN	1,69	2,61 kg
KWS 050E	215 mm	500 mm	570 mm	590 mm	6,3 kN	1,91	2,95 kg
KWS 060E	215 mm	600 mm	670 mm	690 mm	6,1 kN	2,13	3,29 kg
KWS 070E	215 mm	700 mm	770 mm	790 mm	5,2 kN	2,60	3,64 kg
KWS 080E	215 mm	800 mm	870 mm	890 mm	4,4 kN	3,07	3,97 kg



Product	H	B1	B2	L	P _{max}	F _D /P	G
KWS 090E	215 mm	900 mm	970 mm	990 mm	3,6 kN	3,56	4,32 kg
KWS 100E	215 mm	1000 mm	1070 mm	1090 mm	2,8 kN	4,06	4,67 kg

Stainless steel, according to ASTM 31 Ti / AISI 316 L, BS 320S17 / BS 316S11

Product	H	B1	B2	L	P _{max}	F _D /P	G
KWS 020E4	215 mm	200 mm	270 mm	290 mm	7,0 kN	1,31	1,92 kg
KWS 030E4	215 mm	300 mm	370 mm	390 mm	6,7 kN	1,49	2,26 kg
KWS 040E4	215 mm	400 mm	470 mm	490 mm	6,5 kN	1,69	2,61 kg
KWS 050E4	215 mm	500 mm	570 mm	590 mm	6,3 kN	1,91	2,95 kg
KWS 060E4	215 mm	600 mm	670 mm	690 mm	6,1 kN	2,13	3,29 kg
KWS 070E4	215 mm	700 mm	770 mm	790 mm	5,2 kN	2,60	3,64 kg
KWS 080E4	215 mm	800 mm	870 mm	890 mm	4,4 kN	3,07	3,97 kg
KWS 090E4	215 mm	900 mm	970 mm	990 mm	3,6 kN	3,56	4,32 kg
KWS 100E4	215 mm	1000 mm	1070 mm	1090 mm	2,8 kN	4,06	4,67 kg

H: height
B1: width
B2: width
L: length
P_{max}: Maximum load
F_D/P: dowel-to-anchor load
G: weight

DETAILS / APPLICATIONS



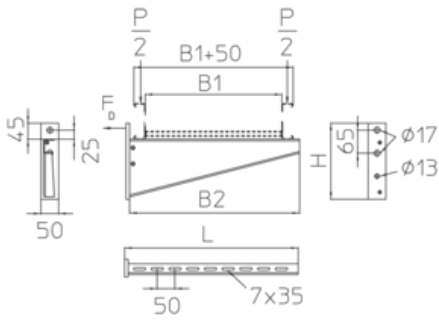

OPTIONAL ACCESSORIES

SD, KDU 57, KLU, WPHS-K

