

KSLW-BS

wall bracket, light-duty Maintenance of function - Standard support structures

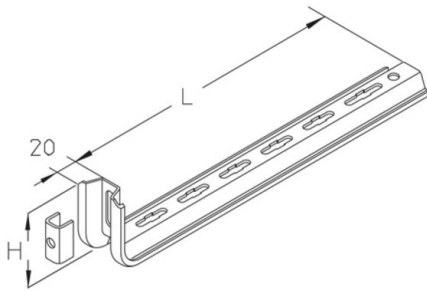

Wall bracket, light version made of W-/trapezoidal profile 60x20 mm, perforated in the center. For mounting on walls. support distance max. 1.2 m.

F_D/P : coefficient for calculation of the dowel load F_D with effective bracket load P respectively the sum of effective bracket loads. This product is only to be used in conjunction with the cable tray for standard support construction. The productes can be used for fire protection. For technical parameters, see National Technical Test Certificates (abPs).

Continuously hot galvanized (Sendzimir process) (DIN EN 10346)

Product	H	L	G
KSLW-BS 010S	90 mm	170 mm	0,44 kg
incl.:			
KSLW-BS 020S	90 mm	270 mm	0,61 kg
incl.:			
KSLW-BS 030S	90 mm	370 mm	0,78 kg
incl.:			

Hot-dip galvanized, according to BS 729 (DIN EN ISO 1461)

Product	H	L	G
KSLW-BS 010F	90 mm	170 mm	0,47 kg
incl.:			
KSLW-BS 020F	90 mm	270 mm	0,65 kg
incl.:			
KSLW-BS 030F	90 mm	370 mm	0,82 kg
incl.:			

H: height



L: length
G: weight

DETAILS / APPLICATIONS

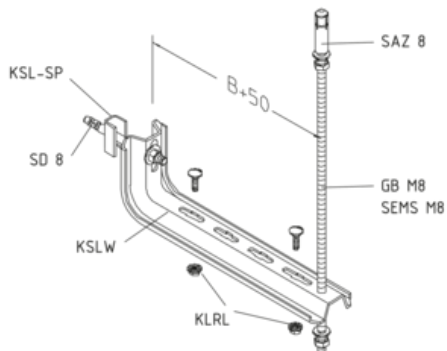

OPTIONAL ACCESSORIES

SD, SAZ, KLRL, GB, VM

