

KSL

handle bracket, light-duty

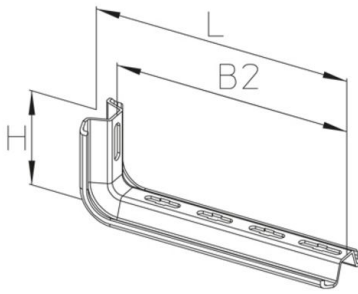

Handle bracket, light version made of W-/trapezoidal profile 60x20 mm, perforated in the center. Certified according to DIN EN 61537. For mounting on ceiling bracket KDSL. support distance max. 1.2 m.

F_D/P : coefficient for calculation of the dowel load F_D with effective bracket load P respectively the sum of effective bracket loads. Load specifications only apply for mounting as wall bracket.. For ceiling mounting, use item KSLW.

Continuously hot galvanized (Sendzimir process) (DIN EN 10346)

Product	H	B1	B2	L	P_{max}	G
KSL 010S	90 mm	100 mm	120 mm	140 mm	1,3 kN	0,38 kg
incl.: 1x FRS 8X20 1x SEMS 8 round-head screw with square, DIN 603 hexagon-nut with flange, DIN EN 1661						
KSL 015S	90 mm	150 mm	170 mm	190 mm	1,0 kN	0,47 kg
incl.: 1x FRS 8X20 1x SEMS 8 round-head screw with square, DIN 603 hexagon-nut with flange, DIN EN 1661						
KSL 020S	90 mm	200 mm	220 mm	240 mm	0,9 kN	0,55 kg
incl.: 1x FRS 8X20 1x SEMS 8 round-head screw with square, DIN 603 hexagon-nut with flange, DIN EN 1661						
KSL 025S	90 mm	250 mm	270 mm	290 mm	0,7 kN	0,63 kg
incl.: 1x FRS 8X20 1x SEMS 8 round-head screw with square, DIN 603 hexagon-nut with flange, DIN EN 1661						
KSL 030S	90 mm	300 mm	320 mm	340 mm	0,6 kN	0,71 kg
incl.: 1x FRS 8X20 1x SEMS 8 round-head screw with square, DIN 603 hexagon-nut with flange, DIN EN 1661						
KSL 040S	90 mm	400 mm	420 mm	440 mm	0,5 kN	0,88 kg
incl.: 1x FRS 8X20 1x SEMS 8 round-head screw with square, DIN 603 hexagon-nut with flange, DIN EN 1661						



Hot-dip galvanized, according to BS 729 (DIN EN ISO 1461)

Product	H	B1	B2	L	P _{max}	G
KSL 010F	90 mm	100 mm	120 mm	140 mm	1,3 kN	0,40 kg
incl.: 1x FRS 8X20E round-head screw with square, DIN 603 1x SEMS 8E hexagon-nut with flange, DIN EN 1661						
KSL 015F	90 mm	150 mm	170 mm	190 mm	1,0 kN	0,49 kg
incl.: 1x FRS 8X20E round-head screw with square, DIN 603 1x SEMS 8E hexagon-nut with flange, DIN EN 1661						
KSL 020F	90 mm	200 mm	220 mm	240 mm	0,9 kN	0,58 kg
incl.: 1x FRS 8X20E round-head screw with square, DIN 603 1x SEMS 8E hexagon-nut with flange, DIN EN 1661						
KSL 025F	90 mm	250 mm	270 mm	290 mm	0,7 kN	0,67 kg
incl.: 1x FRS 8X20E round-head screw with square, DIN 603 1x SEMS 8E hexagon-nut with flange, DIN EN 1661						
KSL 030F	90 mm	300 mm	320 mm	340 mm	0,6 kN	0,75 kg
incl.: 1x FRS 8X20E round-head screw with square, DIN 603 1x SEMS 8E hexagon-nut with flange, DIN EN 1661						
KSL 040F	90 mm	400 mm	420 mm	440 mm	0,5 kN	0,94 kg
incl.: 1x FRS 8X20E round-head screw with square, DIN 603 1x SEMS 8E hexagon-nut with flange, DIN EN 1661						

H: height
B1: width
B2: width
L: length
P_{max}: Maximum load
G: weight

DETAILS / APPLICATIONS



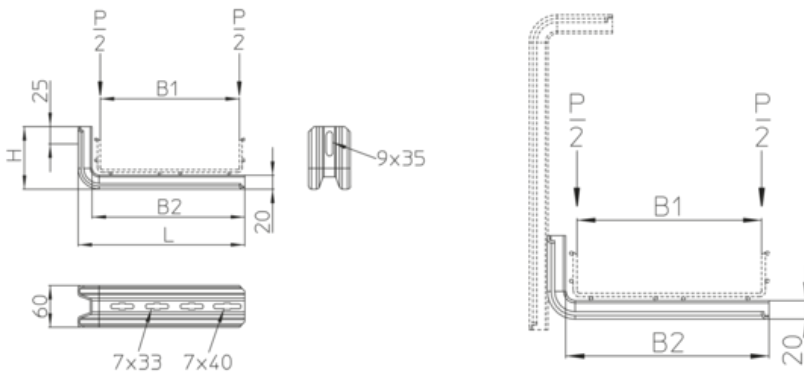

OPTIONAL ACCESSORIES

KDSL, KLRL

