

KHZ

Z profile

Alternating alignment must be observed while mounting.

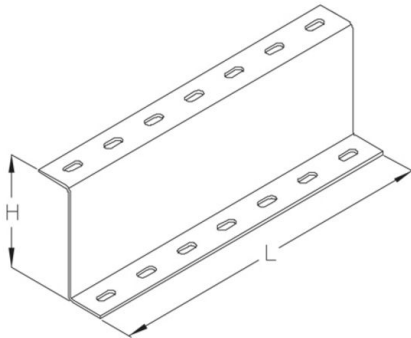

Continuously hot galvanized (Sendzimir process) (DIN EN 10346)

Product	H	L	t	G
KHZ 80-01S	80 mm	100 mm	3,00 mm	0,32 kg
KHZ 80-02S	80 mm	200 mm	3,00 mm	0,65 kg
KHZ 80-03S	80 mm	300 mm	3,00 mm	0,98 kg
KHZ 80-04S	80 mm	400 mm	3,00 mm	1,31 kg
KHZ 80-05S	80 mm	500 mm	3,00 mm	1,64 kg
KHZ 80-06S	80 mm	600 mm	3,00 mm	1,97 kg
KHZ 80-30S	80 mm	3000 mm	3,00 mm	9,88 kg
KHZ 100-01S	100 mm	100 mm	3,00 mm	0,37 kg
KHZ 100-02S	100 mm	200 mm	3,00 mm	0,74 kg
KHZ 100-03S	100 mm	300 mm	3,00 mm	1,12 kg
KHZ 100-04S	100 mm	400 mm	3,00 mm	1,49 kg
KHZ 100-05S	100 mm	500 mm	3,00 mm	1,86 kg
KHZ 100-06S	100 mm	600 mm	3,00 mm	2,23 kg
KHZ 100-30S	100 mm	3000 mm	3,00 mm	11,18 kg
KHZ 120-01S	120 mm	100 mm	3,00 mm	0,4 kg
KHZ 120-02S	120 mm	200 mm	3,00 mm	0,9 kg
KHZ 120-03S	120 mm	300 mm	3,00 mm	1,3 kg
KHZ 120-04S	120 mm	400 mm	3,00 mm	1,8 kg
KHZ 120-05S	120 mm	500 mm	3,00 mm	2,2 kg
KHZ 120-06S	120 mm	600 mm	3,00 mm	2,6 kg
KHZ 120-30S	120 mm	3000 mm	3,00 mm	13,19 kg

Page.1



H: height
L: length
t: material thickness
G: weight

DETAILS / APPLICATIONS

