

KDU 60

bracket support, heavy, 60x40 mm Maintenance of function, specified system

ceiling bracket support heavy building class, U-profile 60x40x4 mm, continuously three-way perforated, with welded head plate (material thickness t), certified according to DIN EN 61537

The product can be used for fire protection. For technical parameters, see National Technical Test Certificates (abPs).

Hot-dip galvanized, according to BS 729 (DIN EN ISO 1461)

Product	L	t	G
KDU 60-02F	200 mm	6,00 mm	1,4 kg
KDU 60-03F	300 mm	6,00 mm	1,8 kg
KDU 60-04F	400 mm	6,00 mm	2,1 kg
KDU 60-05F	500 mm	6,00 mm	2,5 kg
KDU 60-06F	600 mm	6,00 mm	2,8 kg
KDU 60-07F	700 mm	6,00 mm	3,2 kg
KDU 60-08F	800 mm	6,00 mm	3,5 kg
KDU 60-09F	900 mm	6,00 mm	3,9 kg
KDU 60-10F	1000 mm	6,00 mm	4,2 kg
KDU 60-11F	1100 mm	8,00 mm	4,8 kg

L: length
t: material thickness
G: weight

DETAILS / APPLICATIONS



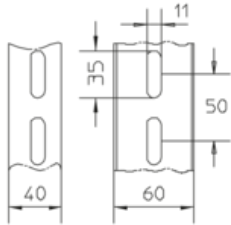
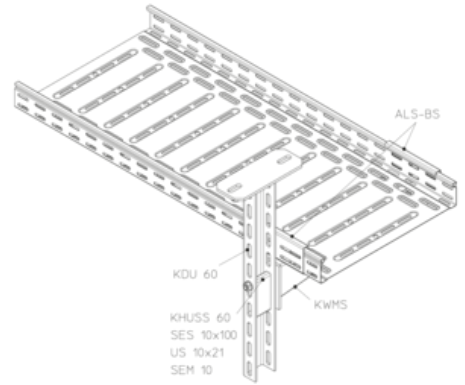
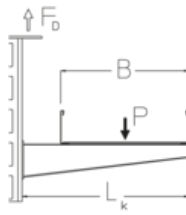
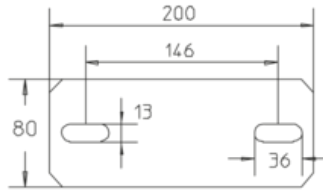

B	L _k	F _d /P
mm	mm	
100	120	1,2
200	220	1,5
300	320	1,9
400	420	2,2

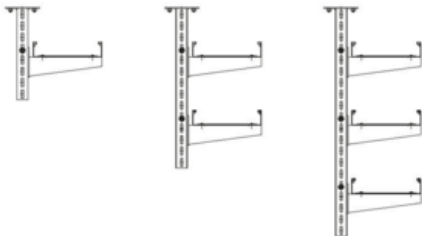

OPTIONAL ACCESSORIES

SD, SAZ

