

# HF-EU 5-6

HF-cable clamp for flat-steel profile fastening

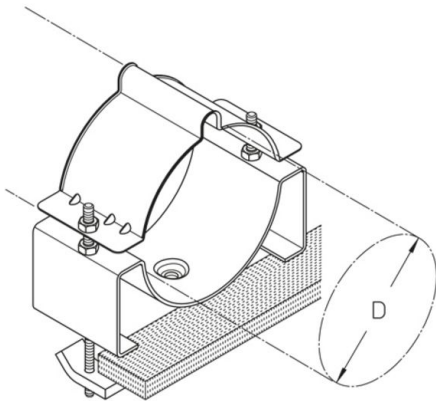

Zinc coated

Product	D	G
HF-EU 5	128 (E 26-30) mm	102 kg/100
HF-EU 6	160 (E 20) mm	117,7 kg/100

**D:** diameter  
**G:** weight

## DETAILS / APPLICATIONS

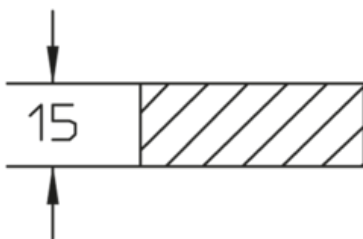



## OPTIONAL ACCESSORIES

HF-EE

