

HF-ES 80 1-4

HF-cable clamp for angular profile fastening

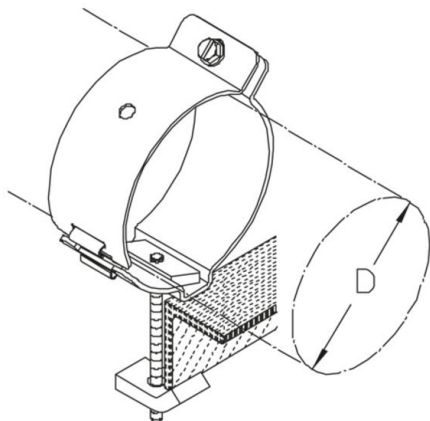

Zinc coated

Product	D	G
HF-ES 80 1	37 (E 130-190) mm	24,9 kg/100
HF-ES 80 2	50 (E 78-105) mm	26,3 kg/100
HF-ES 80 3	62 (E 60-70) mm	28,3 kg/100
HF-ES 80 4	100 (E 38-46) mm	35,4 kg/100

D: diameter
G: weight

DETAILS / APPLICATIONS

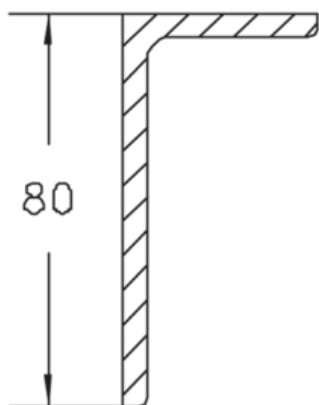

OPTIONAL ACCESSORIES

HF-EE

